

CAPE LOOKOUT LIGHTHOUSE

Cape Lookout National Seashore
North Carolina

HISTORIC STRUCTURE REPORT



December, 2008

for

**Cultural Resources, Southeast Region
National Park Service**

by

JOSEPH K. OPPERMAN—ARCHITECT, P.A.
539 North Trade Street Winston-Salem, NC 27101
336/721-1711 FAX 336/721-1712
jorskopp@mindspring.com

TABLE OF CONTENTS

MANAGEMENT SUMMARY

Executive Summary	1
Administrative Data.....	6

PART I – DEVELOPMENTAL HISTORY

A. HISTORICAL BACKGROUND AND CONTEXT	I.A.1
Introduction	1
America’s Lighthouse Program.....	2
Sending Out a Light	5
Changing Communication Technology.....	9
Life of the Keeper.....	10
B. CHRONOLOGY OF DEVELOPMENT AND USE	I.B.1
Establishment of Cape Lookout Light Station	1
Improvement Needed	5
A New Light for Cape Lookout	6
William Henry Chase Whiting.....	7
Plans and Construction.....	9
Reuse of 1812 Tower	14
A Storm on the Land	14
Reestablishing the Light.....	16
A Daring Raid	16
Recovery of the Fresnel Lens.....	17
Post War Repairs	19
1873—A New Look	19
Improving the Light.....	21

Storm Door and Air Lock.....	22
Becoming Part of the National Park Service.....	26
Removal of the Fresnel Lens—Again.....	27
Shoring the Interior.....	27
Continuing Maintenance.....	28
National Park Service Assumes Control.....	31
TIMELINE.....	33
BIBLIOGRAPHY.....	37

C. PHYSICAL DESCRIPTION.....	I.C.1
General Description:.....	1
Construction Characteristics.....	3
Structural Systems.....	3
Utility Systems.....	9
Exterior Features.....	10
Interior Features - Typical Characteristics.....	18
Interior Features – By Room.....	23
Summary of Conditions.....	45
Limitation of Inherent Design Characteristics.....	45

PART II – TREATMENT & USE

B. ULTIMATE TREATMENT & USE.....	II.A.1
Building Fabric: Significance.....	1
Building Fabric: Condition.....	2
Change in Use.....	3
The Challenge.....	3
Recommended Ultimate Treatment.....	4

B. REQUIREMENTS FOR TREATMENT.....II.B.1

C. ALTERNATIVES FOR TREATMENT.....II.C.1

 Alternative Treatment #1.....1

 Alternative Treatment #2.....2

 Alternative Treatment #3.....3

D. RECOMMENDATIONS.....II.D.1

 Actions to Achieve Recommended Ultimate Treatment.....1

 Recommended Limitations as per IBC & Stair Landing Capacity.....3

 Other Recommended Actions.....3

APPENDICES

- A. Documentation Drawings
- B. Structural Assessment/Carrying Capacity Analysis
- C. Code Compliance and Recommendations
- D. Materials Analysis
- E. Class C Construction Cost Estimate

EXECUTIVE SUMMARY

Explorers of the North American coast feared the southern tip of what is now known as the Core Banks off North Carolina. So hazardous to navigation was this area that early cartographers labeled it *Promontorium tremendum* (“horrible headland”).

The Cape Lookout Shoals on these maps extend approximately ten miles in a southeasterly direction from the point of the cape. The shoals are generally sandy, shifting to some extent with the heavy gales and strong tidal currents that cross them. In the middle is located the infamous Cape Lookout Breakers, three-quarters of a mile long, with a depth as shallow as two feet. Navigation was made all more treacherous with the convergence of the strong currents and storms that rapidly form in this area. Because the land was so low along this section of the coast, an approaching ship could be dangerously close to shore without realizing it. Often, the recognition came too late.

Despite the danger, it was not until 1804, that the United States Congress authorized the construction of a lighthouse “...on or near the pitch of Cape Lookout.” And it was until 1812 that the first Cape Lookout Lighthouse Station was completed. The station consisted of a tower and keeper dwelling.

In 1851 problems among America’s lighthouses seemed endemic and a special board was appointed to prepare a general assessment. The board concluded that at a height of ninety-five feet above the level of the sea, the light of the 1812 Cape Lookout

Light Station was too low and too dim for the task of this “very important light.” Therefore, in 1857, Congress appropriated \$45,000 “for building and fitting out with first-order apparatus the lighthouse at Cape Lookout, North Carolina.” Adapting a stock plan then in use for a first-order lighthouse, First Lieutenant William Henry Chase Whiting, District 5 Engineer of the U.S. Lighthouse Board, assumed the task of overseeing construction which was completed in late 1859. At a respectable 163 feet and outfitted with a French, first-order Fresnel lens, the new lighthouse was a marked improvement.

During the War Between the States, Confederates removed the valuable Fresnel lens and hid it away from the advancing Union forces. Then, when the lighthouse was secured by Union troops, a Confederate band in 1864 caused an interior explosion that destroyed sections of cast-iron stairs, temporarily disabling the facility. After the War, permanent repairs were completed, the Fresnel lens recovered and reinstalled, and the lighthouse was once again fully operational.

Over time, small modifications were made and new equipment periodically installed. One of the most noticeably significant changes was the application of the black-and-white, diamond-pattern, paint scheme. First applied in 1873 to enhance visibility and recognition, it became a much-admired mark of distinction.

The Fresnel lens which had revolutionized the transmission of light remained a mainstay. Improvement efforts concentrated

on the source of light itself. Initially, sperm whale oil was used to fuel the lamps. By late 1883, mineral oil was introduced and in 1912 an incandescent oil vapor lamp was installed. When an occulting device was installed in 1914, giving the light two distinct eclipses, the modification greatly enhanced mariner identification of the lighthouse and dramatically improved navigational safety along the coast. Two decades later, the candlepower of the light was doubled with the introduction of electrical battery power in 1933; a radio signal was also added.

As these operational improvements were implemented, there was, in general, little physical impact to the lighthouse itself. The most significant changes occurred in 1914 with installation of the occulting device. To better isolate the new equipment, the Observation Deck was enlarged and an air lock constructed at the doorway from the deck to the tower. In addition, other air locks were constructed of wood at the Seventh Floor Service Room and Second Floor main entrance. More significant was the impact to the activities of the staff. With these technological advancements, many of the arduous tasks of the early workdays were reduced or eliminated and the types of needed staff skills changed accordingly.

In 1939 the United States Lighthouse Service was discontinued. Its equipment and personnel were transferred to the United States Coast Guard. With the arrival of World War II, Cape Lookout, as with other lighthouses, was darkened to avoid illuminating the passing ships; the lighthouse instead became an observation platform for detecting enemy submarines.

After the war, the Coast Guard continued to maintain the tower and modernize its

operation. In 1950, new generators and batteries were installed, this time at the ground level room of the tower itself. Thereupon, the lighthouse became self-contained and fully automated, no longer requiring the presence of an on-site keeper. The lighthouse continued to be powered in this manner until 1982, when electric cables were run from Harkers Island.

In 1966, another branch of the United States government became involved with the Cape Lookout Lighthouse. Act of Congress (P.L. 89-366) authorized the creation of Cape Lookout National Seashore. Then, on October 18, 1972, the station “consisting of the lighthouse, the keeper’s dwelling, a generator house, a coal and wood shed, and a small cement block oil house—all situated on a long narrow sandy island called Core Banks” was placed on the National Register of Historic Places.

When in 1976 Cape Lookout National Seashore was established with headquarters in Beaufort, the U.S. Coast Guard, nonetheless, retained control of the lighthouse site. In 1982, the Cape Lookout Coast Guard Station was decommissioned and its function merged with the station at Fort Macon. In 1984, the station’s property and buildings were transferred to the National Park Service. The Coast Guard continued to retain possession of the lighthouse itself.

During the earliest days of this transitional phase of ownership, the first major modification to the Cape Lookout Lighthouse occurred since the 1914 enlargement of the Observation Deck and installation of a series of air locks. It occurred in 1967, one hundred years after the return and reinstallation of the first-order Fresnel lens. The historic lens was removed.

This time, it was removed in the quest for a brighter light. The Coast Guard replaced the historic lens with two powerful 24-inch aero-beacons, the lights now in place. The historic lens was first placed on display at the entrance to the Mess Hall and Base Exchange of the 5th District Coast Guard Headquarters. Then in 1994, it was installed at the newly renovated Block Island Lighthouse off Rhode Island. There it remains, despite requests to have it returned to Cape Lookout.

The second major change planned for the lighthouse since the 1914 alterations occurred in 1989. The railings of the Lantern Gallery and Observation Deck were replaced and the Gallery deck reinforced with steel angles and rods. Inside, the masonry tower was reinforced with steel bracing extending from below the Seventh Floor level up to the Lantern. For installation, a number of the original cast-iron steps were cut and sections of the 1914 air locks and room walls removed.

During the waning years of the last century and early years of the current one, a series of well-intentioned but unfortunate maintenance tasks also were implemented. In combination, they are proving to be of serious detriment to the building fabric and perhaps the occupants as well. The paint used for the exterior during this time is a plasto-elastic variety. While it is durable and appropriate for some materials, it is a non-vapor transfer coating which works contrary to the relatively low-fired, soft brick as found in this lighthouse which need a breathable coating. Working in concert with this misstep, are two other unfortunate repairs. One was the erosion-inducing water blasting of the tower, inside and out; the blasting clearly damaged the once-harder, protective outer surface of the brickwork

and accelerated deterioration is occurring. The second repair actually may be a series of repairs. At least part of the repointing of the masonry was performed with a Portland-cement rich mortar. This mortar is both too hard for the bricks and lacks the needed vapor transfer characteristics.

These three repairs in unison probably account in large part for the reports from 1992 and 1995 that record heightened moisture problems inside the tower resulting in the presence of mold and rusting of the iron stairs.

In June, 2003, the Coast Guard turned over control of the lighthouse to the National Park Service while retaining operational control of the light. On the day the lighthouse opened to the public, the crowds were unprecedented. More people ascended the tower's stairs in a few days than had in the previous one hundred-plus years. In addition, the following year a Coast Guard survey of the public regarding the quality and usefulness of the light revealed a strong public appreciation for the lighthouse far beyond its initial purpose. Clearly, the lighthouse has become an important local attraction as well as a navigational aid.

Concern for the safety of the public in their increased numbers visiting the lighthouse led to the suspension of public tours in February of 2008. The National Park Service Southeast Regional Office (NPS-SERO) subsequently contracted with Joseph K. Oppermann – Architect, P.A. (JKOA) to prepare this Historical Structure Report with a structural assessment/carrying-capacity analysis, a code compliance analysis with stair-loading recommendations, the testing of certain building materials and the preparation of a budget for repairs. On site investigations of the lighthouse took place

during the summer and fall of 2008. Joseph K. Oppermann, FAIA and John C. Larson jointly conducted assessments of the age of the building components. Oppermann also prepared field measurements and conducted assessment of physical condition of architectural elements. Mark Kasprzyk prepared digitized drawings. Larson also reviewed documentary source material, primarily those provided by the park, and prepared historical summaries. Hartrampf, Inc., led by Bob Bass, P.E., and assisted by Stacey Gerhardt, EIT, prepared the “Structural Assessment/Carrying Capacity Analysis” (Appendix B of this report). Oppermann prepared the “Code Compliance and Stair Loading Recommendations” (Appendix C) in consultation with Todd Neitzel of NPS-SER. Dorothy Krotzer of Building Conservation Associates took samples, conducted analyses of selected building materials and prepared the “Material Analysis” (Appendix D). Oppermann with Bass prepared the “Class C Construction Cost Estimate” (Appendix E). Russell J. Wilson, park superintendent, made available all aspects of the park operation and its personnel. Karen Dugan compiled the park documents and collected additional references. Mike McGee arranged travel between the park’s offices and the lighthouse and shared his considerable knowledge of the park’s recent construction history. Frances Hayden, registrar of the North Carolina Maritime Museum, generously gave of her time to locate salvaged Cape Lookout Lighthouse material in the museum’s collection and to arrange for material sampling. Tommy Jones, NPS-SERO architectural historian, provided guidance in all aspects of the preparation of this report.

The investigations and analyses concluded that a large percentage of the original 1859

building fabric and the 1867 repairs remain intact. And the 1873 exterior paint scheme gave the tower its distinctive black-and-white diamond pattern which it retains today. Further, the later modifications dating through most of the twentieth century tended to be limited in scope; most have had minor impact on the character of the lighthouse. The 1914 enlargement of the Observation Deck and addition of air locks were the most significant.

The 1989 addition of steel reinforcement both inside and outside the top of the tower was a significant change in character, however. One that stabilized but did not correct a long-developing weakness. The investigations identified the deteriorating iron tension ring imbedded at the top of the masonry and associated ironwork of the lantern as the unalleviated sources of the masonry jacking.

The investigations also identified recent maintenance efforts, including the uses of water blasting for masonry cleaning, Portland-cement rich mortars for repointing and elasto-plastic paints for replacement coatings, as serious threats to the well being of the lighthouse.

Also a concern, the one that prompted this study, is the safety of the visiting public who are arriving in large numbers. While the resultant loading of the early building material is potentially well in excess of the original design intent, when the lighthouse was to be daily occupied by just one or two persons, modern building codes are also a factor in determining acceptable loading capacities. The International Building Code, which addresses the safety of the public and governs the use of this building, sets tight parameters for occupancy for buildings of this design. Some modifications to the

building, ones that are in keeping with the historic designs, can be made to enhance public safety and improve the durability and performance of building elements, such as the iron stairs; Appendix B describes these modifications. However, the IBC is the greater limiting factor and administrative policies best address the code constraints. Fortunately, the policies implemented by the park for its annual Climb SOP are a successful model for such administrative actions and therefore have been incorporated into the report's recommendations.

The General Management Plan for the Cape Lookout National Seashore was prepared prior to the acquisition of the Cape Lookout Lighthouse. Therefore, the lighthouse is not addressed in the plan. Nonetheless, the National Park Service Cultural Resources Management Guideline (DO – 28) requires planning for the protection of cultural resources on park property.

In addition, Section 106 of the National Historic Preservation Act (NHPA) mandates that federal agencies, including the National Park Service, take into account the effects of their actions on properties listed or eligible for listing in the National Register of Historic Places and give the Advisory Council on Historic Preservation a reasonable opportunity to comment.

The Park Service has the challenge of balancing its responsibility to protect important cultural resources with its responsibility to educate the public. While there are many ways to address education short of actual visitation, there is no question that a trip to South Core Banks and a visit to the lighthouse is a most impressive experience. However, access to the site and throughout the building can be problematic

for some visitors. It is arduous; some should not attempt it at all.

The park, in cooperation with a friends' group, has established a goal of conducting public tours of the lighthouse including access onto the Observation Deck. This report concludes that such public visitation is an admirable goal and one that is doable, both in terms of performance capabilities of the building materials and code requirements protecting the safety of the public. However, minor physical modifications, coupled with administrative policies to limit the number of visitors, will be necessary. This report also identifies other needs that must be addressed very soon in order to provide for the long term preservation and public use of this important landmark.

Accordingly, the Recommended Ultimate Treatment includes the preservation of the exterior and interior, the restoration of key exterior features to their c. 1976 appearance (reversing several minor yet highly visible modifications), and the rehabilitation of certain features to more safely accommodate public visitation.

ADMINISTRATIVE DATA

Locational Data

Building Name: Cape Lookout Lighthouse
Building Address: 131 Charles Street
Harkers Island, NC 28531
Location: Cape Lookout National Seashore
County: Carteret County
State: North Carolina

Related Studies

Primary

Cape Lookout Lighthouse Letter Book Index 1805-1900. Copy on file in Cape Lookout National Seashore archives. "Cape Lookout Light House, First Order, From Lieut. W.H.C. Whiting, 5th Dist" ca. May 1857. [623/60937] and "U.S. Light House Board, Cape Lookout Light House, Drawn under the direction of Lieut. Wm. H.C. Whiting, Corps Engr by Benj. Goodness" Same as above with additional annotation 1888 and checkering detail. [623/60937A].

"Cape Lookout L. House N.C., Temporary repairs wooden in Indian yellow, Drawn by G. Castor Smith Actg. Engr. 4th L. H. Dist., From measurements by Jere. P. Smith" dated 28 July 1864. [623/60936A]

"Cape Lookout Light Station, N.C. Storm Door & Parapet Floor. Bureau of Lighthouses, Washington, D.C. Sept. 10, 1913." [623/60915] with "Cape Lookout Light Station, N.C. New Air Lock & Repairs, Bureau of Lighthouses, Washington, DC, Sept 10, 1913." [623/60916] and "Reinforcing Rods in Parapet Floor, Cape Lookout Lt. Stn., Office of the Lighthouse Inspector Fifth District, Baltimore, MD," Jan. 16, 1914. [623/60918]

Secondary

Report of the Officers Constituting The Light-House Board convened under instructions from the Secretary of the Treasury to Inquire into the condition of the lighthouse establishment of the United States under the Act of March 3, 1851. Washington: A. Boyd Hamilton, 1852.

Duffus, Kevin P. *The Lost Light, The Mystery of the Missing Cape Hatteras Fresnel Lens.* Raleigh, NC: Looking Glass Publications, 2003.

Putman, George R. *Lighthouses and Lightships of the United States.* Boston: Houghton Mifflin Co. 1917. Online pdf available at <http://www.books.google.com>.

Real Property Information

Acquisition Date: 1976: Cape Lookout National Seashore established; U.S. Coast Guard retained control of lighthouse site.
1984: property and buildings transferred to National Park Service; Coast Guard retained possession of lighthouse.
June 14, 2003: transferred to Department of Interior.

Numbering Information

LCS #: 000018
Structure #: HS-100-A
FMSS # (Location #): 97012

Size Information

Total Floor Area: approximately 650 s.f.
First Floor Area: approximately 115 s.f.

Roof Area: 9,700 s.f.
Circumference: 87'-11 ½" l.f. at ground level
Number of Stories: Eight stories
Number of Rooms: Ground floor and six landings
Number of Bathrooms: No bathrooms

Cultural Resource Data

National Register Status: Listed: “the lighthouse, the keeper’s dwelling, a generator house, a coal and wood shed, and a small cement block oil house—all situated on a long narrow sandy island called Core Banks”
National Register Date: Listed October 18, 1972
Period of Significance: 1858-

Proposed Treatment

Preservation of the exterior and interior, the restoration of key exterior features to their c. 1976 appearance, and the rehabilitation of certain features to more safely accommodate public visitation.

A. HISTORICAL BACKGROUND AND CONTEXT

The Lighthouse

*...some miles away,
the lighthouse lifts its massive masonry,
A pillar of fire by night, of cloud by day.
Steadfast, serene, immovable, the same,*

*Year after year, through all the silent night
Burns on forevermore that quenchless flame,
Shines on that inextinguishable light!*

Henry Wadsworth Longfellow
(c. 1848)

Introduction

A wealth of literature—poetic, technical and historic—has been generated about the lighthouses in America. Scholars such as F. Ross Holland and Robert and Cheryl Roberts have dedicated lifetimes to the study and dissemination of information on this topic. As a distinctive architectural form, the lighthouse’s function shifted in the twentieth century from a place of work to one of recreation. Improved transportation made lighthouses more accessible. That brought increasing awareness of their historical significance and widespread appreciation of their architecture. The history of America’s lighthouses records their decline as a navigational aid and a corresponding rise in their perception as a romantic icon of our nautical past. With their images imprinted on T-shirts and coffee mugs and their small model replicas used as everything from bookends to yard ornaments, lighthouses have been embraced



Figure A-1 Photograph of Cape Lookout Lighthouse, ca. 1910, courtesy of John Willis.

in popular culture as a source of local identity and pride that the original builders could hardly have imagined. The story of the 1859 Cape Lookout Lighthouse mirrors this development and is not dissimilar in its history from most other lighthouses along the coastlines of the United States.

The 1915 definition of a lighthouse by the U.S. Bureau of Lighthouses is “a light station where a resident keeper(s) is employed.”¹ The primary elements were a light tower and keeper’s quarters but typically there were other support buildings. Cape Lookout Lighthouse included an oil house, privy, storage sheds, coal and

¹ Ray Jones, *The Lighthouse Encyclopedia, the Definitive Resource* (Guilford, CT: The Globe Pequot Press, 2004), 105.

woodshed, boathouse, cistern and summer kitchen. As an omen of things to come, a radio shack and battery house was later added.² All of these buildings performed an essential role in the day-to-day operations. One of the most important pieces of equipment in lighthouse operation was a boat. Powered by oars, or a perhaps a small sail, these vessels allowed the keepers to access the mainland or supply vessels or assist in rescues. However, as long as light remained the principal method of communicating warnings out to sea, the tower was the principal place of work and the reason for a station's existence. Activities of the tower dictated the daily lives of those who occupied the station.

Although viewed as a solitary existence, lighthouse management by the Federal government, particularly under the Light House Board established in 1852, as well changing technology continually affected the viability of lighthouses and the daily activities of the lighthouse keepers.

America's Lighthouse Program

Although lighthouses trace back to the ancient construction by the Pharos in Alexandria, Egypt, their development has always had a direct correlation to the nautical endeavors of a particular place and time. With the decline of travel and navigation after the fall of Rome in AD 476 the use of lighthouses also declined. The fifteenth-century saw renewed sailing skills

and a new age of lighthouse construction. The Little Brewster Island Lighthouse, constructed in 1716 at the entrance of Boston Harbor, was the first to be built in America. During the colonial period, the individual colonies assumed responsibility for the construction and maintenance of the lighthouses on their shores. Often these towers were paid for by the merchants and businessmen at each individual location and supported by levying a duty on each ton of shipping that entered the harbor. Consequently, there were no standards for their priority, placement, construction or operation.

The adoption of the Constitution created a Federal government empowered to address this kind of national concern. Aids to navigation were a high priority. On August 7, 1789, President Washington signed into law the ninth act passed by the newly formed Congress. The law provided that "the necessary support, maintenance and repairs of all lighthouses, beacons, buoys and public piers erected, placed, or sunk before the passing of this act, at the entrance of, or within any bay, inlet, harbor, or port of the United States, for rendering the navigation thereof easy and safe, shall be defrayed out of the treasury of the United States."³ The administrative responsibility was placed under Secretary of Treasury, Alexander Hamilton. During this period, most of the state-owned lighthouses were transferred to the Treasury. For example,

² "Plat of Cape Lookout Light Station N.C. Showing proposed location of new Keeper's Dwelling &c. Dimensions received from Mr. John W. Lewis Supt. Of Construction, July 31, 1906." Copy on file in archives of Cape Lookout National Seashore, Harker's Island, NC.

³ Truman R. Strobridge, *Chronology of Aids to Navigation and the United States Lighthouse Service 1716-1939*. at http://www.uscg.mil/history/articles/h_USLHSchron.asp (19 July 2008); Act of Congress (1 Stat. L., 53).

the lighthouse first started by the State of North Carolina, at Bald Head near the mouth of the Cape Fear River, was completed by the United States in 1796.

Initially, Alexander Hamilton assumed personal responsibility for this activity, but in 1813, the administration of lighthouse matters was delegated to the Commissioner of Revenue within the Treasury Department. In 1820, it was placed under the authority of the Fifth Auditor of the Treasury. At that time there were approximately seventy lighthouses in operation under the Department of the Treasury. For the next thirty-two years, one man, Stephen J. Pleasonton, would establish a program of conservative frugality that limited the quality of the towers and the effectiveness of the lights they contained. Pleasonton was particularly steadfast in his resistance to acquiring the expensive French Fresnel lenses. He opted instead to continue to use the inadequate lamp and reflector system developed by Winslow Lewis. As early as 1812, Congress authorized the Secretary of the Treasury to purchase Lewis's patent for a "reflecting and magnifying lantern and to contract with the said Winslow Lewis for fitting up and keeping in repair, any or all of the lighthouses in the United States or territories thereof, upon the improved plan of the reflecting and magnifying lanterns."⁴

Pleasonton's administration was brought to an end in part by public outcry after the wreck of the *Saint John* on Minots Ledge off the coast of Massachusetts in October in 1849 and the subsequent collapse of the

Minots Light in 1851. Shortly thereafter, Congress appointed a nine-member commission to investigate the condition and effectiveness of America's lighthouses. As a result of their report, Congress created the Lighthouse Board and gave it authority over all America's navigational aids. The Board was composed of two officers of the Navy, two officers of the Engineer Corps, and two civilians of high scientific attainments who served at the pleasure of the President, with an officer of the Navy and of the Engineers as secretaries. It was empowered under the Secretary of the Treasury to administer lighthouses and other aids to navigation. The Secretary of the Treasury was president of the Board, but the Board was authorized to elect their own chairman and to divide the coast of the United States into twelve lighthouse districts. Each district was assigned an army or navy officer as lighthouse inspector. Cape Lookout was in District 5.

In 1910, the Lighthouse Board was disbanded and the U.S. Bureau of Lighthouses, more commonly known by its operational arm, the U.S. Lighthouse Service, was created. George Putnam was appointed the first Commissioner of Lighthouses, a position he held for the next twenty-five years. At its height just before World War I, the U.S. Lighthouse Service operated about 1,200 lighthouses and 54 lightships with the total of 11,713 navigational aids.⁵

⁴ Ibid. Act of Congress (2 Stat. L., 691).

⁵ Samuel Willard Crompton and Michael J. Rhein, *The Ultimate Book of Lighthouses* (San Diego: Thunder Bay Press, 2003), 26.



Figure A-2 Logo of USLHS.

By order of President Franklin D. Roosevelt, in 1939 the U.S. Coast Guard was assigned responsibility for all the functions of the Bureau and all personnel, equipment and property was placed under its administration. Since that time the U.S. Coast Guard has been the operational stewards of America's lighthouses. Only recently have the National Park Service and other non-profits taken possession of these buildings as the Coast Guard began systematically to declare them surplus.

Sending Out a Light

The first beacons were nothing more than a lantern or a bonfire built on a hilltop. Early eighteenth-century light towers relied on multiple candles and simple oil lamps to produce enough light to be seen at a distance, hence the quantity of light was measured in candlepower. From this modest start, two principal areas of inquiry developed to improve the quality of the light in the towers. One was the fuel; the other was the fixture or lamp.

In the later part of the eighteenth-century American lighthouses were using spider lamps, which had a number of wicks protruding from a common fuel reservoir. To obtain adequate light, multiple lamps were needed. Depending on the number of wicks per lamp, sometimes as many as thirty lamps were used. These wicks demanded constant attention, smoked and consumed a large quantity of fuel.⁶



Figure A-3 Augustin Fresnel, 1788-1827.

The first major improvement in light production was development by the Frenchman Francois-Pierre Ami Argand in the mid-eighteenth century. Seeking to capture the light that diffuses horizontally and vertically at 360 degrees from the center, Argand designed a set of lamps and parabolic reflectors to capture and redirect that light horizontally. He also redesigned the wick for the oil lamps. Argand's wicks

⁶ Francis Ross Holland, *America's Lighthouse: An Illustrated History* (New York: Dover Press, 1988), 21-23.

were hollow, which allowed air to pass evenly on both sides of the flames, creating a brighter and near smokeless light. France and England quickly adopted this method of illumination. It was not until 1812 that the unemployed sea captain, Winslow Lewis, persuaded the U.S. government to adopt his lamp system, no doubt copied from the Argand lamps he had seen in Europe. By about 1816, the Lewis lamp had been installed in all of America's lighthouses.

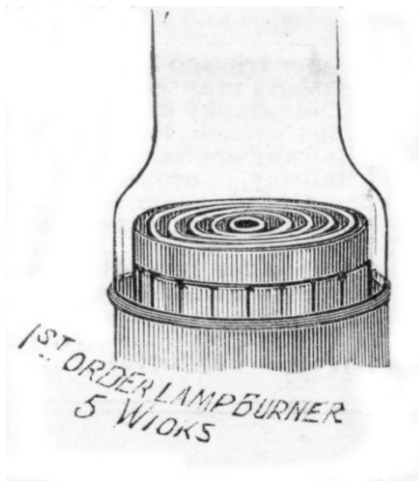
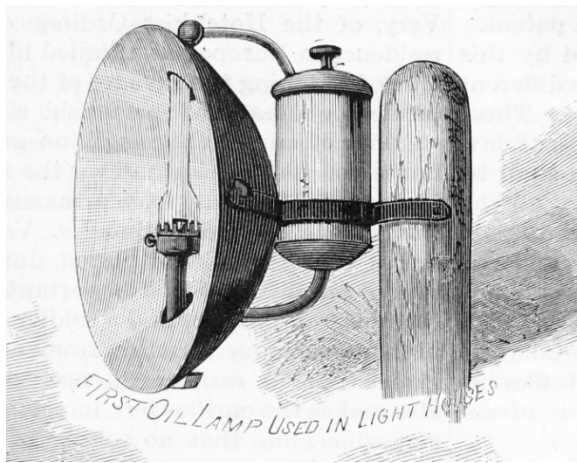

Figure A-5 Example of Argand reflector lamp (top) and 1st Order Fresnel wick (bottom).

For the next forty years, Fifth Auditor Stephen Pleasonton remained committed to this technology, and Lewis held a virtual

monopoly on lighthouse lamps and lighting.⁷ Although the Argand lamp burned cleaner and transmitted more light, it still required multiple fixtures to achieve an adequate light level. The quest for better illumination continued in Europe along a different line of investigation.

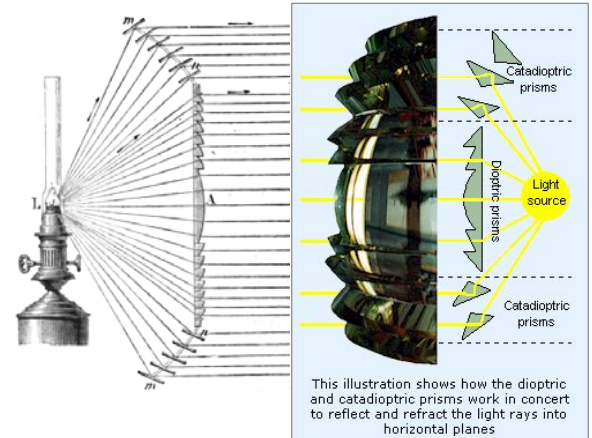

Figure 0-4 The use of Fresnel lenses to reflect and refract light to a horizontal plane.

In 1822, the French physicist, Augustin Fresnel developed a complex lens, which could concentrate light into a powerful beam. It consisted of hundreds of hand-polished prisms which, when assembled, took on the appearance of a large beehive. Scotsman Alan Stevenson acquainted himself with the Fresnel lens in 1830 and launched its use in the British Isles. He also made some modifications to Fresnel's original design, including the addition of upper and lower prisms that significantly increased the efficiencies of the lens.⁸ Later bull's-eye convex lenses, like a magnifying glass, were added to the center of the lens, making the beam even more powerful.

⁷Crompton and Rhein, 15-16.

⁸ Ray Jones, *The Lighthouse Encyclopedia: The Definitive Reference* (Guilford, CT: The Globe Pequot Press, 2004), 14.

These lenses could also rotate on a pedestal, creating a flash when the center of the bull's-eye on the lens lined up with the ship out at sea viewing the light. Different spacing of the multiple bull's-eyes on each lens resulted in different intervals between their flashes, thus creating a unique pattern for each lighthouse, and helping navigators to identify their location along a coastline. Different colored lenses, as well as different colored light sources, were also used as a way to distinguish lighthouses from one another.

Although very complex and expensive, the Fresnel lens became the universal standard for over a hundred years. One of the major advantages to the lens was its ability to reduce the amount of fuel required to produce a good light. Instead of multiple lamps with reflectors, burning a great deal of oil, a single lamp could be used. This single lamp would use a multi-concentric-wick design combining up to five wicks to produce a single flame.⁹

The results of this new technology were impressive. Tests showed that an open flame would lose approximately 97 percent of its brightness over a very short distance. A flame with an Argand or Lewis reflector lamp would still lose 83 percent. The Fresnel lens could capture all but 17 percent of the light and, when placed at a 150 foot high focal plane, could achieve a distance of approximately 20 miles.¹⁰ This height became critical particularly along the southern coast where there were few hills or

cliffs to give the towers the required elevation.

In 1840 Captain Matthew Perry delivered the first pair of Fresnel lenses to the United States, which were placed in the twin towers at Navesink, Highlands, N. J. Although the improved quality of the light brought much acclaim, it would take another ten years and the replacement of Fifth Auditor Pleasanton by the Lighthouse Board in 1852 before the United States fully embraced this new technology.

Cape Lookout would be part of a new generation of tall brick towers that were constructed in the 1850s along the Atlantic coast, with the tallest, Cape Hatteras, capping out at 193 feet. All of these were furnished with new, powerful first-order Fresnel lens, and by 1861, nearly all American lighthouses had been upgraded with a Fresnel lens.¹¹

It is understandable that the fiscally conservative Pleasanton was reluctant to acquire Fresnel lenses. They were expensive and could command as much as the equivalent of one million dollars in today's money. The Fresnel lenses were classified by orders, which were based on their sizes. The first-order was the largest at six feet in diameter and twelve feet tall. The smallest or sixth-order was one foot in diameter and one foot, five inches tall.¹²

⁹ <http://www.longislandlighthouses.com/fresnel.htm>.

¹⁰ <http://www.michiganlights.com/fresnel.htm>.

¹¹ Crompton and Rhein, 16.

¹² *Ibid.*, 87-89; also <http://www.michiganlights.com/fresnel.htm>.

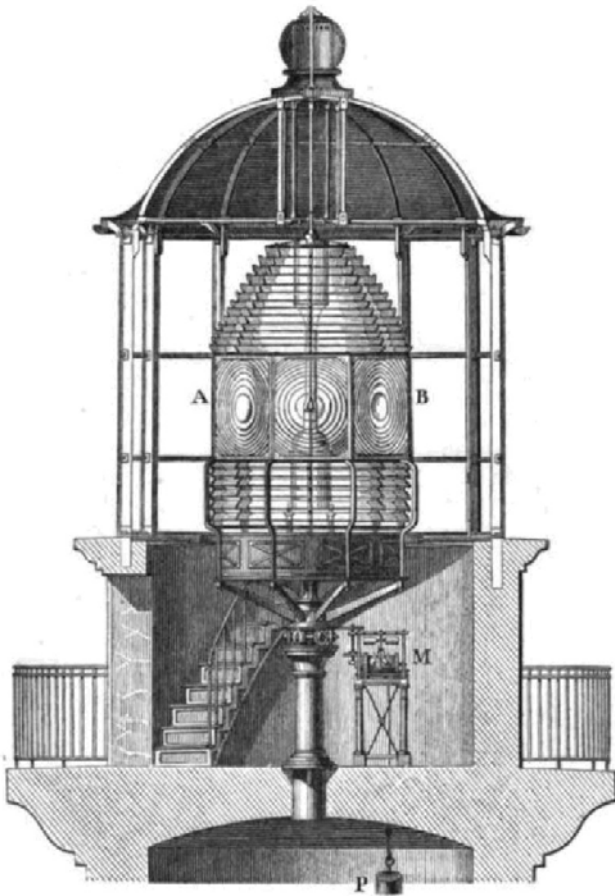

Figure A-5 Watch Room with Fresnel lens installed in lantern

Most of the lenses were produced in France by such firms as Henry-Lepaute, the manufacturer of the Cape Hatteras first-order light, and Lemonier, Sauter & Co., maker of the Cape Lookout light. In 1851, the English firm of Chance Brothers Co. began extremely successful production of the lens in Birmingham. Macbeth-Evans was the only American manufacturer of Fresnel lenses, and they limited their operation to supplying only fourth-, fifth- and sixth-order lenses.

This quantum leap in lamp technology would remain state-of-the art for more than a hundred years, but by mid-nineteenth

century attention was returning to the issue of fuel. Sperm whale oil had been the standard fuel for years regardless of the lamp type. By 1855, however, the price of sperm oil had jumped to \$2.25 per gallon from its 1841 price of \$.55. The Lighthouse Board searched for alternatives. Attempts were made to follow the French example and use rapeseed or colza oil, but a consistent supply from American farmers proved elusive. In the late 1850s, Joseph Henry of the Lighthouse Board resumed his research on lard. After earlier attempts had failed, Henry now discovered that if the oil was heated to a high enough temperature, it did extremely well. Lard was cheap and plentiful, so Colza oil was assigned to the smaller lights, and lard, by 1867, was used in many of the larger lamps.¹³ Cape Lookout remained one of the exceptions and continued to use oil as its fuel.¹⁴

In the 1870s, the Lighthouse Board again started looking for an alternative fuel. By 1878, kerosene—popularly known at the time as mineral oil—began to be used, initially in the smaller lamps but eventually in all sizes. Cape Lookout converted to mineral oil in 1883.¹⁵ In 1902, the consumption of oil for a first-order light was calculated to be 2,283 gallons of oil per year,¹⁶ all of which had to be transported in

¹³ Holland, *Illustrated History*, 23.

¹⁴ *Cape Lookout Lighthouse Letter Books Index*. July 5, August 2, 1867; December 3, 1873. At this writing, the letter books for Cape Lookout remain missing; however, the *Index* provides valuable insight. Copy on file at Cape Lookout National Seashore, Harker's Island, NC.

¹⁵ *Index*, December 26, 1883.

¹⁶ *Instructions to Light-Keepers* (Washington: U.S. Government Printing Office, 1902), 14.

five-gallon cans from the oil house up the hundreds of stairs to the Watch Room.

The last technical upgrade prior to the installation of electricity was the invention of the Incandescent Oil Vapor (I.O.V.) light. Operating similar to a modern Coleman lantern, kerosene is vaporized against a hot wall, forced through small holes to a mantel where it burns in a fireball. This light fixture was first installed in France in 1898 and America in 1904. Refinements in this technology continued. A new type of oil-vapor lamp was developed during 1911, which was believed to be “an improvement on existing lamps of this character, as it gives a greater candlepower per unit of oil used and practically does away with the carbonization of the oil, which has been a defect of previous types of oil-vapor lamps.”¹⁷ The following year an I.O.V. was installed in Cape Lookout. Because this location required a more powerful light, a lamp with three burners and a cluster of three mantles was installed.¹⁸

Changing Communication Technology

By the turn of the century, however, another technological revolution was in the making—electricity. Initially it changed how the light was created in the lighthouses, but more significantly it opened the door to other methods of communications that would eventually eliminate the need for manned light towers.

¹⁷ *Annual Report of the Commissioner of Lighthouses to the Secretary of Commerce and Labor for the Fiscal Year Ended June 1911* (Washington: U. S. Government Printing Office, 1911), 15.

¹⁸ Putnam, 188.

As early as 1892, electric incandescent lamps were installed in the United States Lightship No. 51 stationed on Cornfield Point. In 1898, the Navesink lighthouse that had been the location for the first Fresnel lens was also the first to have an electric arch lamp installed and supported by its own generating plant. Perhaps more importantly, it was from this Navesink location that the first wireless message was sent and received between the *S.S. Ponce* and the lighthouse. In 1901, radio communication was experimentally established on the Nantucket lightship.¹⁹ At the start of the twentieth-century, it was increasingly apparent that a new age of electronic communication was dawning.

Generators were introduced where power lines were not available, and in the 1920s and 30s the Lighthouse Bureau converted most of the lighthouses to electricity. Cape Lookout was electrified August 15, 1933, with four 250-watt lamps and also received a radio beacon. The new light bulbs simply replaced the I.O.V. lamps and left the Fresnel lenses in place.

In the early 1950s, the Carlisle and Finch Co. of Cincinnati, Ohio, introduced a new airport beacon known as the DCB series. Using a parabolic reflector housed in a solid cast-aluminum, watertight drum, the fixture was low maintenance. It emitted a very narrow beam and, when rotated, created a flash pattern. Cape Lookout received its two DCB-24 aero-beacons ca. 1976. By the 1990s, this lighting system had replaced

¹⁹ Strobridge, *n.p.*

most first-order Fresnel lens in lighthouse lanterns.²⁰

Life of the Keeper

Like any piece of equipment, a lighthouse needed an operator—and more often than not, two or three—to keep things running smoothly. In September, just before the 1859 Cape Lookout Lighthouse was to be brought on-line, John R. Royal was reappointed keeper.²¹ He was first appointed the keeper at the 1812 Cape Lookout Station in January 1834 and since that date, he had managed the light in the smaller tower by himself. The size of the new tower and the complexity of the first-order Fresnel lens, plus higher performance expectations by the Lighthouse Board were more than one man could handle. On September 27, two assistants were appointed, A. P. Guthrie and Silas Blount.²²

If quality control had been a shortcoming of the Fifth Auditor Pleasonton's administration, the new Lighthouse Board quickly put into place a program of regulations and inspections aimed toward establishing uniformity and accountability. Regulations were codified in the 1852 publication *Instructions to Light-Keepers*. Each keeper and all assistants received a copy and were held strictly accountable for following its procedures. This manual would be revised and updated until lighthouse operation was absorbed into the U.S. Coast Guard. If adhered to, it prescribed a strict daily regime of cleaning

the lamp, lens, and lantern glass and lantern room. Dress code required wearing a uniform, but to protect the lens and lamp, a special cloth apron was worn to keep buttons and buckles from scratching the glass. Daily logs and recurring reports accounted for the activities of the keeper and his assistants. The District Engineer or Lighthouse Inspector verified these reports with regular site inspections. The business of maintaining the light was foremost, but there were numerous other tasks required to maintain the station in good order.

The keeper's logs for Cape Lookout have not been located, but the activities and responsibilities described by Lloyd Vernon Gaskill, keeper of Bodie Island Lighthouse just to the north, seem typical.

(1) As keeper in charge of this station, I am responsible for the for the [sic] proper execution of the duties whether performed by myself or Asst. I light lamp in tower every othe [sic] evening and raise curtains so light will be visible to passing ships. Asst. Keeper performs the same duty the following evening. I watch the light intervals until sunrise when I extinguish light and refill tanks with kerosene so it will be ready for lighting in the evening. Also I clean lens and watch room before coming down to dwelling. I am on duty about twelve hours in this instance. (2) I have one Asst. and I superintend and assist in painting, cleaning paint on outhouses and dwellings, clean iron work by chipping ruse [sic] from same when needed. Also keep grass cut on lawn, make minor repairs to sta. such as replaceing [sic] lantern glass when broken, repairing

²⁰Crompton and Rhein, 79-80.

²¹ *Index.*, September 9, 1859.

²² *Index.*, September 25, 1859.

*doors, replaceing [sic] hinges when broken, painting motor boat and skiff, keep engine repaired so it can be used at any time for getting supplies and mail from nearest store and post Office seven miles across the sound. I put in about five hours per day at this work. (3) In addition to the above duties I must make a weekly inspection of Sta. Including assistant's quarters and record made of conditions of Sta. log. Make monthly report of condition of Sta. to district Supt. at Baltimore. Take annual inventory and list all articles worn out have them surveyed and condemed [sic] when Supt visits sta. on inspection. Also I superintend and assist in the painting of tower outside, steps inside, and whitewash once every five years. I attend to all correspondence from sta. with supt. relative to general repairs to station. I average about two hours per day on this work.*²³

There were other duties that Keeper Royal is known to have performed at Cape Lookout. He watched for and reported on all wrecks in his vicinity. If he could lend any assistance to the wreck, he was instructed to do so. One of his more macabre jobs was burying a body that washed ashore.²⁴ By 1902, the keepers were also acting as conservation wardens charged with the task of preventing trees from being cut on Federal lands and assuring compliance with state game laws. More specifically, regarding birds, "It is most desirable that not

only the game animals of the country but that song birds and birds of all kinds should be protected and encouraged to occupy their abodes in their natural habitats and the Light House Board directs that all persons in the service not only exercise this spirit of protection but encourage others to do likewise."²⁵

Prior to the Civil War, the annual salary for a keeper at Cape Lookout was \$400, while an assistant would earn \$300. After 1869, assistants consistently earned \$400 while keepers earned from \$700 to \$760.²⁶ The big benefit was free room and board. The diet can be gleaned from the following table:

Table of annual allowances per man for light-stations and fog-signals stations

<i>Pork.....</i>	<i>200 pounds</i>
<i>Beef.....</i>	<i>100 pounds</i>
<i>Flour.....</i>	<i>2 barrels</i>
<i>Rice.....</i>	<i>50 pounds</i>
<i>Brown Sugar.....</i>	<i>50 pounds</i>
<i>Coffee (green grain).....</i>	<i>24 pounds</i>
<i>Beans or pease [sic].....</i>	<i>10 gallons</i>
<i>Vinegar.....</i>	<i>4 gallons</i>
<i>Potatoes.....</i>	<i>2 barrels</i>

Whether it was the isolation, the salary, the demands of the job or the rigor of the inspections, personnel turnover was reported frequently. At Cape Lookout the station had been fully manned with a keeper and two assistants for just over a year when the Civil War resulted in its abandonment. The new keeper appointed in 1863, Gayer Chadwick,

²³ Bodie Island Lighthouse Historic Structure Report, 13. http://www.nps.gov/history/history/online_books/caha/caha_bodie_hsr.pdf

²⁴ *Index.*, March 17, 1856.

²⁵ *Instruction to Light-Keepers* 1902 edition. 8, 12.

²⁶ *Lighthouse Keepers of Cape Lookout Lighthouse 1845-1912*, National Archives Microfilm Publication Micro Copy 1373 Roll 3.

would resign the following year.²⁷ Perhaps in desperation to locate qualified keepers, John R. Royal was rehired only to be removed along with his two assistants in what appears to be a house cleaning on May 21, 1869. An episode in which the light was extinguished in January 1875 may have ultimately resulted in the August 19, 1876 dismissal of M.W. Mason and his two assistants. Mason held the keeper job during the painting of the “checker” pattern on the lighthouse. Keeper M.J. Davis, who followed Mason, would be removed as was his successor W. F. Hatsel. Denard Rumley, who followed Hatsel, died in 1893 while on duty.²⁸ Tenure of just two years was certainly not uncommon.

The U.S. Coast Guard assumed control of the lighthouse just a couple of years before World War II. Slow to respond to the German submarine threat, America’s Atlantic coast was not darkened until June of 1942. After the war, the lights shown more brightly than ever; they were automated and enhanced with control and backup systems. The direction of navigational aids, however, was apparent. By 1948, LORAN had been extensively deployed along the Outer Banks.

“LORAN, which means *LOng Range Aid to Navigation*, is a modern electronic means by which ship and aircraft navigators can determine their positions accurately and quickly, day or night, and under practically any condition of weather and sea. It was created to meet the emergency conditions of World War II and during that period was

used exclusively by military forces. Since then, LORAN receiving equipment has been available to commercial, as well as military ships and aircraft.

Navigators receive LORAN radio signals from stations like the one at Cape Hatteras, which can transmit signals over an area 750 miles by day and 1,400 miles by night. Signals from two or three stations are matched for accurate position plotting.

Since the war, LORAN has made tremendous growth. Presently under final evaluation is a modified system that will provide a more precise method of position fixing with greater range.

The world-wide LORAN system contains some 70 stations, of which 60 are operated by the United States Coast Guard.”²⁹

Although not installed in Cape Lookout Lighthouse, LORAN was but one in a series of electronic communication breakthroughs that spelled the end of the lighthouse as the primary navigational aid. Today, satellites have ushered in Global Positioning Systems that are affordable and accessible to all means of transportation.

After the war, the U.S. Coast Guard increasingly declared the light towers surplus. Although still a landmark to local fishermen and recreational boaters, their original function had been relinquished to newer technologies. Fortunately, lighthouses have remained in the landscape. With the shift of population to coastal resorts, the lighthouse has become more

²⁷ *Index.*, May 20, 1864.

²⁸ *Index.*, March 9, 1893.

²⁹ United States Coast Guard News Release No. 60-2-26(jbb), June 3, 1960.

visible than ever and is now viewed from land as often as from sea. Lighthouse advocates of today are not the ship owners and sea captains but rather the local merchants and residents who draw comfort from its constant presence and the distinction it gives to their community.

On November 30, 1810, after a five-year delay, the Treasury Department again put the project out to bid, soliciting contractors through the local newspapers along the east

coast. This call for proposals gave an insightful look at the construction details and performance expectations of the first Cape Lookout Lighthouse.

*Treasury Department
November 30, 1810*

Proposals will be received at the office of the Secretary of the Treasury until the 1st day of February next for building a Light House, on or near the pitch of Cape Look Out in North Carolina, of the following materials, dimensions & description.

The Light House to be of wood, The form octagonal, The foundation of Stone, to be sunk as far as necessary below the surface of the earth, the lowest tier of which, to consist of large flat stones, to be thence carried up two feet above the surface of the earth. It is to be commenced of the diameter of fifty five feet where the wall is to be three feet thick, The foundation wall to be capped with hewn stone of at least eight inches wide sloped to turn off the water; The octagon pyramid of wood is to be of good oak or white pine timber the sticks or pieces of which, are to be of a size duly proportioned to the building, and to be sufficiently braced in all its parts to the acceptance of the person who may be appointed to superintend the building on the part of the United States. The pyramid is to be fifty four feet diameter at the commencement: its height is to be 93 feet from the top of the stone work to the floor of the lantern, at which place it is to be 14 feet in diameter. The frame to be covered with good inch seasoned white pine boards featheredged, over which is to be laid a good roof of cedar or white pine (without sap) shingles, and the outside to be painted with three coats of good paint the last of which to be stripes alternately white and brown.

In the centre of the building there is to be built a brick well for the stairs to run up. The foundation upon which the well is to rest to be commenced of the same depth, as the foundation wall of the frame, and to be twenty feet in diameter, carried up in solid masonry, either of hard brick or stone, from the foundation to the surface of the earth. Upon this foundation the well is to be commenced of nineteen feet diameter. The walls to be two bricks in thickness, and carried up from the foundation to the top of the building or floor of the lantern, where the diameter is to be twelve feet. Within this well stone stairs are to run from the floor to the lantern, not less than one hundred and thirty in number one end going six inches at least into the wall and the other end being a nine inch newell forming a pillar in the centre of the well a quarter-landing to be at each revolution. The whole work to be well bound and good lime mortar used throughout and the bricks to be all sound and good. For the better security and support of the well, there is to be erected around it from the foundation to the top, a substantial frame which is to join the well and is to be connected with the outer frame by timber fixed at each revolution of the stairs, and at other proper distances, in such way as to render the whole perfectly strong & secure & united so as to appear as one frame. The timber to be of the same quality as the outer frame to which it is to be united. The top of the well to be arched (reserving a place for a trap door, which is to be fitted to serve as an entrance to the lantern) on which are to be a sufficient number of substantial iron sleepers

bedded therein and sloping from the centre, which are to be covered first with sheet iron, over which is to be laid a course of sheathing paper well soaked in and paid over with tar, and then with sheet copper over the iron, the whole to be rivetted together, so as that the floor of the lantern thus prepared shall be perfectly tight and strong, and as durable at least as upon the ordinary mode of laying the copper on wood. The trap door to be covered with sheet copper. There are to be two windows in the well at each revolution of the stairs on opposite sides, and also the same number of windows in the Light House opposite and to suit those of the well, each to have eight panes of 10 by 12 glass in strong frames, with shutters & proper fastenings.

The entrance to the well to be by a substantial brick arch, carried up through the Light House at the commencement of the well, of sufficient size and height to pass with convenience from the entrance to the well. The floor of the arch-way to be brick & the Light House floor to be paved with brick. The entrance to the arch to be well secured by a substantial pannelled door with iron hinges, lock and latch complete. On the opposite side there is to be another pannelled door for an entrance into the Light House, hung with hinges, lock & latch complete. The Light House to have a cornice covered with good sheet copper. A complete iron lantern in the octagon form to rest on the floor prepared for it, with a complete set of lamps, to be suspended by good and sufficient iron chains so hung that the lamps may be raised or lowered at pleasure, and also a sufficient number of air-pipes: the eight corner pieces or stanchions of the lantern to be well secured to the parts of the pyramid, and to be three inches square. The lantern to be secured by eight iron braces of two inches diameter, passing through the platform near the eaves, and turned towards the head so as to reach at the eaves, the corner posts of the lantern, to which the braces are to be secured. The lantern to be ten feet in diameter. It is also to be nine feet high from the floor to the bottom of the dome or roof, and to have a dome or roof of five feet in height and covered with sheet copper. The rafters of the lantern, which are to be of iron, are to be framed into an iron hoop, over which is to be a copper funnel through which the smoke may pass into a copper ventilator in the form of a ball sufficient to contain sixty gallons, and large enough to secure the funnel against rain. This ventilator to be turned by a large vane, so that the hole for venting the smoke may be always leeward. The spaces between the posts at the angles to be occupied by the sashes which are to be made of iron struck solid, and of sufficient strength so as not to work with the wind, each sash to be glazed with strong glass 14 by 12 inches, of the first quality, and one of the sashes to be hung on hinges for a convenient door by which to go out on the platform, which is to be surrounded by iron ballustrades three feet high, each rail or rod to be three quarters of an inch square inserted in the braces between the eight posts. The lantern to be painted with three coats and to be surrounded with a netting of iron wire, to preserve it from the flight of birds. The building to be furnished with two complete electrical conductors or rods with points: also, a close stove is to be furnished and placed in the lantern.

An Oil-vault is to be built of brick, twenty feet by twelve in the clear, arched over, plaistered within and covered without with a cement of earth and sand, and over it a roof covered with shingles. The vault to be furnished with nine strong cedar cisterns, with covers, capable of containing 200 gallons of oil each, these cisterns to be sunk in clay properly tempered with sand, which is to be well rammed round, and to be lined with sheet lead carefully soldered to prevent leakage; the entrance to the vault to be secured by a sufficient door hung with hinges & a strong lock and painted.

Also a frame dwelling house, 24 feet square, having one story of eight feet, & a half-story of four feet, divided into three rooms of 12 by 14 feet of 12 by 10 feet and 16 by 12 feet, leaving at one end of the last, 8 by 12 feet for a passage, stairs & closet. There is to be a chimney near the middle of the house with a fire-place to each room. Also an oven & iron or stone mantletrees. The walls of the house to be boarded with good inch pine boards, featheredged, on which is to be laid a good coat of cedar or pine (without sap) shingles. There are to be three chambers. The roof to be rectangular, the boards of which to be jointed & halved & well seasoned and covered with like good shingles as the walls. A sufficient number of windows well glazed, with shutters & the proper fastenings: also doors hung on iron hinges with thumb-latches, and the outside doors to have good locks. The inside walls & ceilings to be lathed & plastered with two coats of good lime mortar, and all the floors to be doubled above & below, and nailed through. The wood work to be painted inside & out with two coats, the roof as well as the walls. To the Dwelling-House is to be annexed a frame Kitchen, placed at the distance of not less than six feet, with a covered way between. The Kitchen to be 16 by 14 feet, of one story by eight feet, to have one pannel-door & one window, & a chimney with one fire place. A well to be sunk & stoned or bricked, at a convenient distance from the house, to be furnished with a curb & the necessary apparatus for drawing water.

The builder is to find & pay for all the materials, labor, workmanship, provisions, and other objects of cost, charge or expense, & to execute the above described work and every part thereof in a good & workmanlike manner, within the time and for a sum to be agreed upon. Bond & Security for the faithful performance of the Contract will be required, convenient payments or advances will be made.

Persons disposed to contract will be pleased to transmit written proposals (which must also specify the shortest time within which they will undertake to complete the works) to either of the undermentioned Collectors of Customs, on or before the 15th day of February next, who will immediately thereafter transmit them to the Treasury Department, from whence notice will be given of the accepted offer, viz:

*Henry Dearborn Esquire of Boston
David Gelston Esquire of New York
Brian Hellen Esquire of Beaufort, North Carolina*

Figure B-2 1810 Request for Proposals, Archives of Cape Lookout National Seashore.

In March 1811, the contract for construction was awarded to Benjamin Beal, Jr., Duncan Thanter and James Stephenson of Boston. The Cape Lookout Light Station, comprised of a tower and keeper dwelling, was completed in 1812 at a cost of \$20,678.54.² All indications are

that the design of a masonry stair tower within wooden exterior shell was followed.³ In May of 1830 an additional eleven acres were purchased from Elijah Pigott and wife for \$75 to protect the

²http://www.uscg.mil/history/web/lighthouses/LHN_C.asp (July 19, 2008).

³F. Ross Holland, *A Survey History of Cape Lookout National Seashore*, (Washington: National Park Service, Cape Lookout National Seashore, 1968), 25.

lighthouse from sand encroachment.⁴ A platting made of the tract at that time provides the only known visual representation of the 1812 lighthouse.

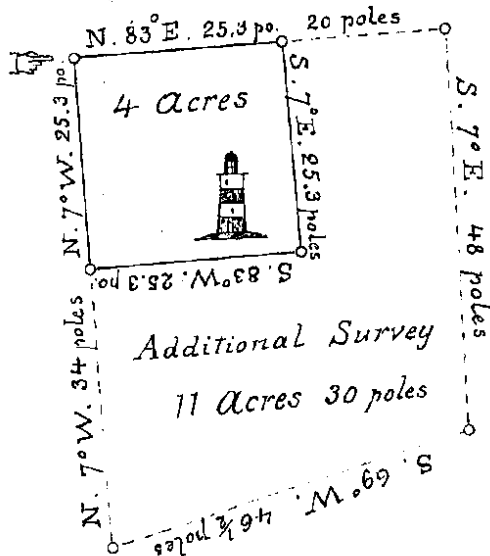

Figure B-3 Tract purchased in 1830. Archives of Cape Lookout National Seashore

The 1847 edition of *The American Coast Pilot* stated,

Cape Lookout Lighthouse is painted red and white stripes horizontally and can be seen 16 or 18 miles and represents a ship under sail. It contains a fixed light, elevated 100 feet above the level of the sea. The house is surrounded by a small growth of trees, from which a bold sand beach extends in a S.E. direction, about 3 miles, in the centre of which are small hillocks of sand. This light, although seen clearly all night, until near the approach of day,

⁴ Carteret Co. Deed Book V, 103.

*cannot then be discerned owing, it is thought, to a mist that rises between the vessel and the lamps It is judged imprudent to approach the shoals of Lookout in the night nearer than 7 fathoms on the east, or 10 fathoms on the west side.*⁵

Improvement Needed

In 1851, a special board was appointed to make a general assessment of the lighthouse problems that seemed endemic on America's coast. The study resulted in an elaborate report of 760 pages and prompted the law creating the Lighthouse Board on October 9, 1852. Regarding the 1812 Cape Lookout Lighthouse, the 1851 assessment noted,

This is at present a fixed light, fitted with thirteen lamps and twenty-one inch reflectors, and elevated ninety-five feet above the level of the sea.

*In consideration of the manner in which navigators have to follow this low coast, this light becomes, necessarily, one of the most important sea-coast lights, and requires to be elevated and improved to that extent. The shoals off this cape are of such character as to render it a very important light.*⁶

⁵ Edmund M. Blunt, *The American Coast Pilot; Containing Directions for the Principal Harbors, Capes and Headlands.* (New York: Edmund & George W. Blunt. 1847) 230; also <http://www.google.com/search?q=The+American+Coast+Pilot+1842&safe=vss&vss=1> (July 13, 2008).

⁶ *Report of the Officers Constituting The Light-House Board convened under instructions from the*

Lieutenant Thornton A. Jenkins, U.S.N. and Assistant to the 1851 U.S. Coast Survey, listed Cape Lookout as one of nine lights that “require to be improved, and there should be no unnecessary delay in accomplishing it.” He made further suggestions that forecast the eventual appearance of Cape Lookout. He stated that each of these proposed towers

...should have an elevation of one hundred and fifty feet above the level of the sea; that they should be fitted up in the best manner with first order lens apparatus, to insure a brilliancy and range adequate to the wants of commerce. These lights are not sufficiently well distinguished but a general plan for all the sea coast lights will best accomplish that object.

Red, black and white, singly and in combination, will afford all the necessary distinctions for towers... A regard to the background must be had in all cases. Red and black show well on the water; white upon dark back ground, the sky, forest, &c., while the sun shines, and the observer is in the position to have the benefit of the reflection; hence there may be combinations by broad horizontal and perpendicular lines, to form all the distinctions which navigators may require.⁷

Secretary of the Treasury to Inquire into the condition of the lighthouse establishment of the United States under the Act of March 3, 1851. Washington: A. Boyd Hamilton, 1852. 138.

⁷ Ibid., 322-323.

Lt. H. J. Harstene, of the U. S. Navy and commanding the U.S mail steamer *Illinois*, filed his complaint with the board and articulated the hazard and frustration in his letter to Lt. Jenkins on July 18, 1851, when he wrote, “The lights on Hatteras, Lookout, Canaveral and Cape Florida, if not improved, had better be dispensed with, as the navigator is apt to run ashore looking for them.”⁸

Although a whole new lighthouse was required at Cape Lookout, a quicker upgrade was urgently needed. In November 1856, an initiative was made regarding “reflectors and lamps to be fitted to a chandelier and sent to Supt. of Lights Beaufort NC.” On January 17, 1857, a shipment of “reflector apparatus with extra lamps and wicks” was shipped to Wilmington, N.C. From Wilmington, on February 14, the “illuminating apparatus” was forwarded to Beaufort to be installed at Cape Lookout Lighthouse.⁹ This improvement, however, was simply a holding action for plans were already being formulated to replace the 1812 tower with a first-order light.

A New Light for Cape Lookout

On March 3, 1857, Congress appropriated \$45,000 “for rebuilding and fitting out with first-order apparatus the lighthouse at Cape Lookout, North Carolina.”¹⁰ The task of overseeing this project fell to thirty-three

⁸ Ibid., 212.

⁹ *Index*, November 26, 1856, January 17 and February 14, 1857.

¹⁰ <http://www.uscg.mil/history/weblighouses/LHN C.asp>. (July 13, 2008).

year old First Lieutenant William Henry Chase Whiting who had taken on the job as District 5 Engineer for the U.S. Lighthouse Board just the year before.

William Henry Chase Whiting

Whiting was an extraordinary man by any measure. Born in Biloxi, Mississippi, March 22, 1824 of Northern parentage, he would follow his father Levi, who was a career artillery officer, into an illustrious military career. Whiting graduated as valedictorian from Boston English High School at age fourteen and then graduated second in his class at Georgetown College at age sixteen. He entered the U.S. Military Academy in 1841 and graduated at the head of his class on July 1845 with a commission as a Second Lieutenant, Corps of Engineers. His grade average was highest of any previous student at the academy. Initially he worked on military installations at Pensacola, Florida, and then on frontier forts in Texas. Promoted to First Lieutenant in 1853, he was assigned to San Francisco to serve on the board of engineers for Pacific coastal defenses. In 1856, he returned east to spend the next five years working on the rivers, canals and harbors of North Carolina, South Carolina, Georgia and Florida. It was during this period that he was responsible for the construction of the Cape Lookout Lighthouse. He married Kate Walker (daughter of Major John G. Walker) in 1857, and in 1858, he was promoted to Captain, Corps of Engineer. On February 20, 1861, weeks before the outbreak of hostilities at Fort Sumter, Whiting resigned



Figure B-4 Maj. Gen. William Henry Chase Whiting, C.S.A. The Engineer of Cape Lookout Lighthouse.

his commission and offered his services to the State of Georgia which appointed him Major, a rank that would transfer over to the Confederate Army. His first months were spent with General G.T. Beauregard preparing the defenses of Charleston Harbor. Soon afterwards he was assigned to North Carolina and placed in charge of coastal defense. He returned to Virginia as Chief Engineer of the Army of the Shenandoah and received a field promotion to Brigadier General after the First Battle of Bull Run. In November 1862, he returned to North Carolina and was assigned to the district of Cape Fear to protect the port of Wilmington.

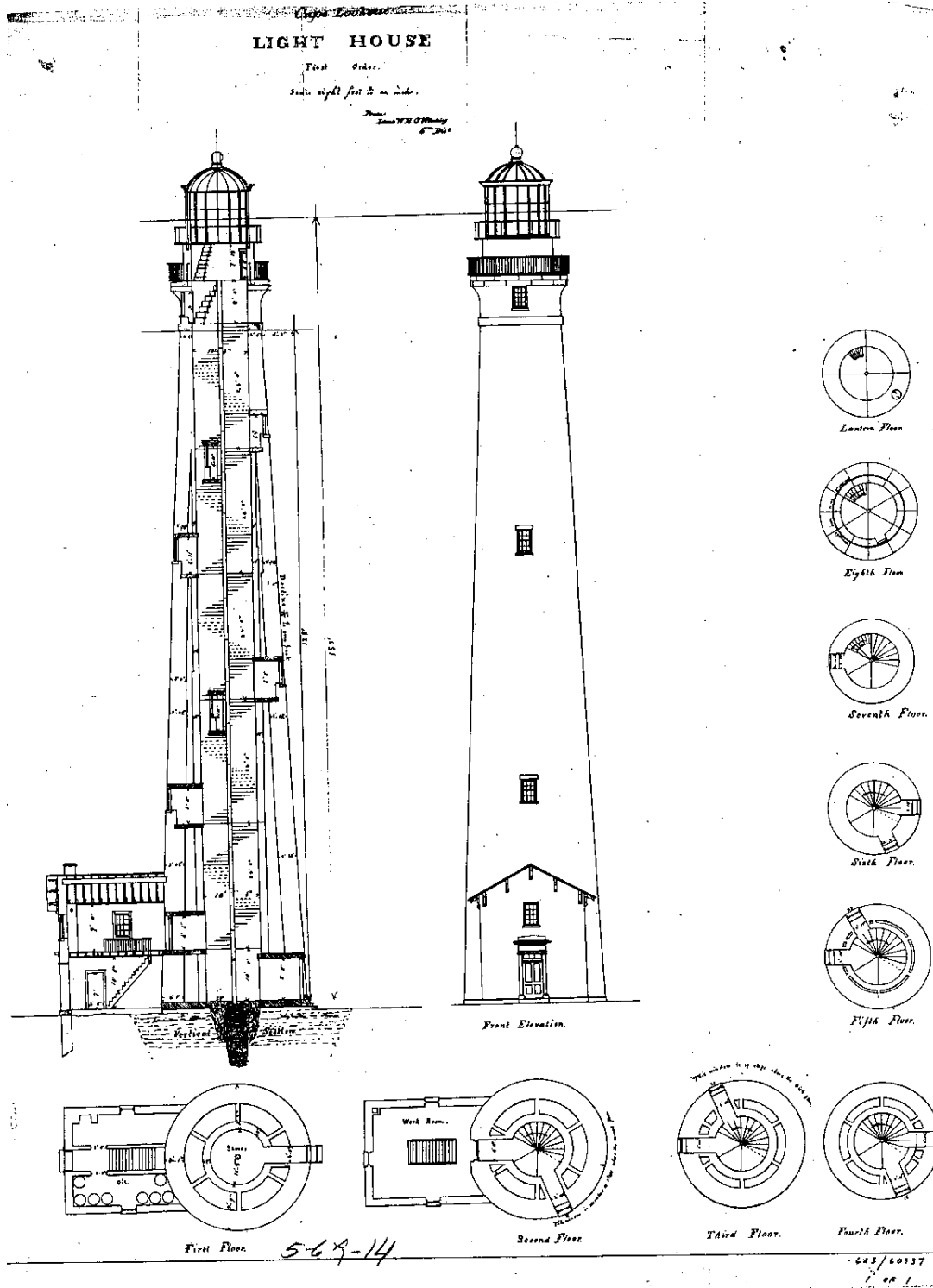

Figure B-5 1857 Whiting's Illustration of Cape Lookout Lighthouse. Archives Cape Lookout National Seashore.

Wounded and captured January 15, 1865, in the battle defending Ft. Fisher, Whiting was imprisoned at Fort Columbus, Governors Island, New York where he died March 10, 1865, at age forty. Whiting was buried in New York City. His widow Kate, however, had his body exhumed in 1900 and moved to Oakdale Cemetery, Wilmington.¹¹

Plans and Construction

In the spring of 1857, Whiting was living in his beloved Wilmington and was deeply involved with the Cape Lookout Lighthouse project, particularly its budget management. By May 27, he had completed and forwarded “tracings of section and elevations of 1st order L.H.Tower.”¹² Two very similar, single sheet, drawings survive fitting this description. Both portrayed a “stock plan” for a first-order lighthouse similar to that forecasted by Lt. Jenkins in the 1851 report. Both carry modified title blocks indicating that this was to be the Cape Lookout Lighthouse and both carry Lt. Whiting’s name.¹³ Although drawn from a “standardized plan” only the tower component would be constructed at Cape Lookout. The drawings show a double wall

masonry tower capped with a first-order lantern creating a 150-foot-high focal plane. There are a total of eight floors plus the lantern floor. The primary entry into the tower was on the second floor with storage on the first or ground floor. At the base of the tower was located a two-story appendage that provided ground-level entry to the building, oil storage and stairs leading to a second-floor workroom and the portal into the tower itself. This part of the plan was never constructed.

Even at a respectable 163 feet, the new Cape Lookout Lighthouse was on the lower end of the new, tall conical-patterned masonry towers being then constructed by U.S. Lighthouse Board. Although the first to be built in North Carolina, on this model this lighthouse was the seventh of ten in construction sequence to be brought on line prior to the Civil War. An additional six were constructed between 1870 and 1887.¹⁴

In June, Lt. Whiting provided estimated costs of the materials needed to construct

¹¹<http://www.ageod.com/forums/showthread.php?t=3140> (July 12, 2008);

<http://www.members.aol.com/jweaver303/nc/whiting.htm> ; <http://www.history.com/this-day-in-history.do?action=Article&id=2132>

Also see C.B. Denson, *Memoir of Major General William Henry Chase White* (Raleigh: Edwards “& Broughton Printers & Binders, 1895) 10-85.

¹² *Index*, May 27, 1857.

¹³ Drawings 623/60937 and 623/60937A, National Archive, Philadelphia, PA. (CALO Coll.).

¹⁴<http://www.uscg.mil/history/web/lighthouses/LHevolution.asp>. (July 15, 2008) In chronological order of construction: 1. Abescon, NJ 1857 (169 feet); 2. Barnegat Light, NJ 1857 (172 feet); 3. Fire Island, NY 1858 (168 feet); 4. Dry Tortugas, Loggerhead Key Light, FL 1858 (157 feet); 5. Cape Romain, SC 1858 (161 feet); 6. Cape May, NJ 1859 (175 feet); 7. Cape Lookout, NC 1859 (163 feet); 8. Hunting Island Light, SC 1859 (destroyed); 9. Pensacola, FL 1859 (171 feet); 10. Jupiter Inlet Light, FL 1860 (125 feet but on hill giving focal plane of 150 feet) 11. Hatteras, NC 1870 (207 feet); 12. Bodie Island, NC 1872 (170 feet); 13. St. Augustine, FL 1873 (165 feet); 14. Currituck Beach Light, NC 1875 (162 feet); 15. Morris Island Charleston, SC 1876 (161 feet); 16. Ponce De Leon mosquito Inlet Light 1887 (175 feet).

the lighthouse.¹⁵ The most critical item to procure was the first-order Fresnel lens. Beginning in August of 1857 and continuing well into October there was correspondence from the firm of Lemonnier, Sauter and Company of Paris regarding the shipping, a bill of lading and invoice for a first-order lens.¹⁶ The indication is that the Fresnel lens was in New York by the fall of 1857, and there it apparently stayed. The next reference to the “Illuminating apparatus for Cape Lookout Light Station” occurred January 6, 1859, which recorded an “inability to ship and no Lt. Ships bound for Beaufort.”¹⁷

After approval of the funds in March, the remainder of 1857 was probably spent refining the building and site plans for the tower and procuring the necessary building materials, including a steam engine and the reuse of some “misfitting lantern glass from Cape Romain” Lighthouse in South Carolina.¹⁸ By April of 1858, construction was clearly underway in earnest with borings being made to determine the need for pilings. Construction must have proceeded steadily throughout the summer with the internal circular cast-iron stair rising in eight-foot segments concurrent with the construction of the masonry walls. Sequentially, the cast-iron center post would be erected first and as the brick courses were laid, the narrow end of each step would be hung on a cast peg protruding from this central column. The

wide end was laid into the masonry itself. At the landings, the small ends of three pie-shaped cast-iron plates were sandwiched between column sections, while the wide end rested in the masonry. Support of these plates was supplemented with a cast-iron “I” beam positioned near the post. The three iron plates provided 180-degree coverage at each landing but were supplemented with single stair tread placed on the same plane.

By the end of November, the “lantern intended for (Cape Lookout L.H. was) received in good order as per Bill of lading.”¹⁹ In the spring of 1859, the tower would be ready for the installation of the Fresnel lens; whenever it could be shipped from New York.

By August 1859, the project was closing down as Captain Whiting requested permission to sell the steam engine used in the construction. In early September, J.R. Royal was reappointed as keeper and by mid-month Whiting reported the completion of the tower.²⁰ The official announcement was made in the form of a *Notice to Mariners (No.43.)* issued September 19, 1859, announcing that the new light would be operational on November 1.

The new lighthouse of 1859 varied slightly in detail from the stock plan submitted by Lt. Whiting in 1857. Most apparent was the absence of the attached oil house at the

¹⁵ *Index*, June 6, 1857.

¹⁶ *Ibid.*, August 27, September, October 12 1857.

¹⁷ *Ibid.*, January 6, 1859.

¹⁸ *Ibid.*, November 12, 1857.

¹⁹ *Ibid.*, November 12, 1857, April 28, November 29, 1858.

²⁰ *Ibid.*, September 9, 17, 27, 1859.

base of the tower. Nineteenth-century photographs indicate that wooden stairs

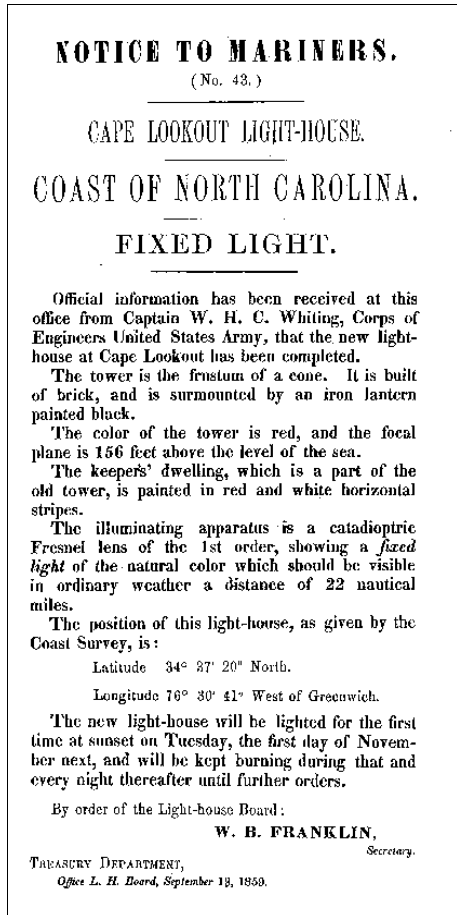

Figure B-6 Notice to Mariners No. 43, Archives Cape Lookout National Seashore.

approached the opening from the side rather than straight on and the portal was protected with a solid, wooden plank, storm door. The distinctive hollow or double wall construction remains an assumption based on the original drawings. To date, no confirmation or recording of this construction detail has been made. Likewise, the detailing of the foundation is not documented. The tower appears to rest on a brick platform that creates a 35-inch walkway around its base. This brick

coursing corbels outward into the ground, but this construction detail is not illustrated in the 1857 drawings and has not been fully revealed archaeologically.

The presence of large granite and sandstone lintels at the two doorways and ten windows contrasted in color and texture with the brick. The *Notice to Mariners* stated that the color of the tower was red. It is not clear if at this point the tower is a brick color, has red paint or perhaps a red lime wash that was often applied as the final step in brick construction. In conformance with Jenkins's suggestions of 1851, red would have been one of the preferred colors for a tower. Most certainly, the lantern was painted black, probably for conservation as well as visibility. To date there is no indication that the original intent was to paint the tower black and white.

What appears more certain is that the center cast-iron post supporting the iron stair treads and the wedge-shaped, flat iron sheets for the landings as illustrated in the drawings were an essential part of the original construction phase of the building. Reports of painting the iron steps in 1862 and needing 61 replacement steps after the Confederate raid of 1864 validate this supposition. The cast-iron ship's ladder stairs leading from the Store Room and the Watch Room conform to the drawings and appear to be original as well. Photographs from the late nineteenth-century indicate that the iron rails at the watch room gallery were simplified to two rails without the balusters shown in the elevation drawing.

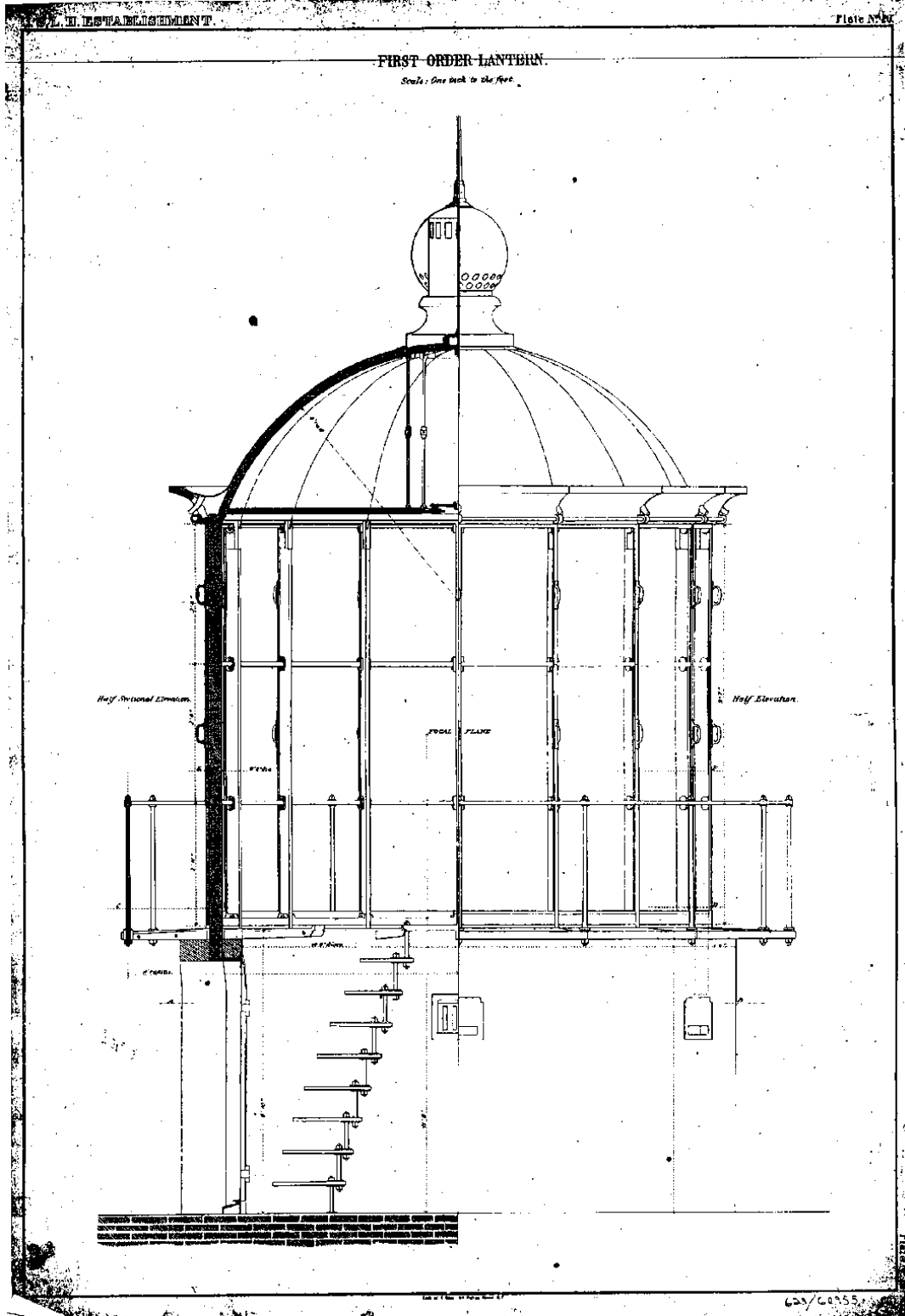

Figure B-7 First-order lantern.

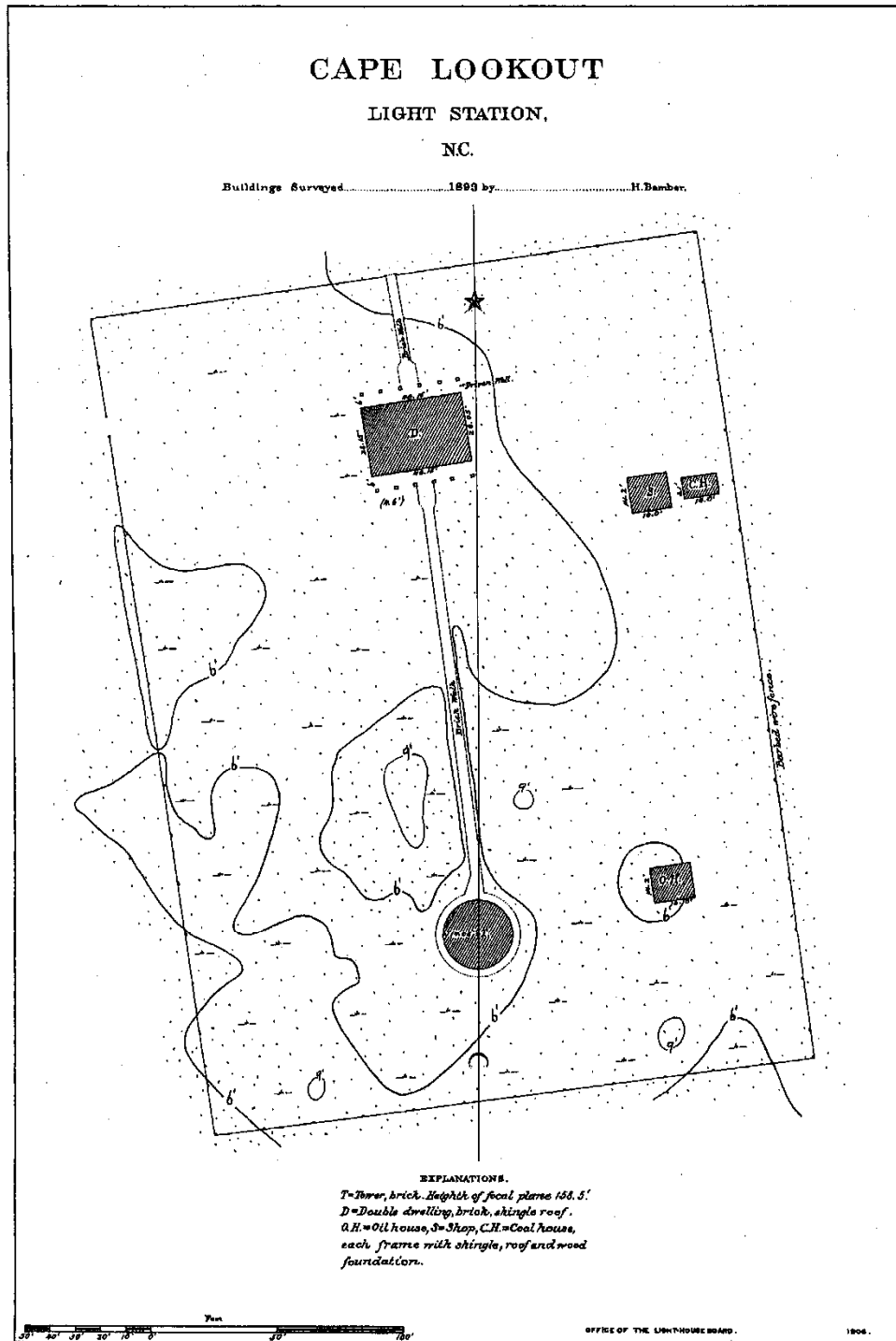

Figure B-8 Plate 1, 1893 Cape Lookout Light Station, NC.

The specially designed lantern gives a consistency and uniformity in the appearance to all the towers designed to accommodate the first-order lens. From the start, the Cape Lookout tower was designed to accept a first-order Fresnel lens, and one was ordered especially for this location. Although the complete letter book has not been located, the index strongly indicates that other lighting apparatus was sent and installed in the 1812 tower early in 1857. The Fresnel lens did not arrive from France until the fall of that year and appears to have been held in New York prior to its installation in 1859. Logistically, this sequence makes more sense than installing the complicated first-order lens in the 1812 tower, whose lantern was probably not designed to accommodate something that large; then having to dismantle and reinstall it in the 1859 tower, with the added complication of insuring that an adequate light was on this location at all times.

Reuse of 1812 Tower

Although the *Notice to Mariners* stated that part of the old tower was now the keeper's dwelling, the completion of this conversion may not have occurred until the spring of 1860. Correspondence from Whiting dated April 25 "reports alteration of old Tower to serve for Keeper's quarters, suggest that upper part of old Tower be taken down." Removal of the lantern was probable, for the following month Whiting requested "instructions in regard to disposal of old illuminating apparatus removed from [Cape Lookout]." ²¹ With the addition of the first

assistant keeper in September and a second assistant keeper in January of 1860, housing was certainly at a premium. It is uncertain just how long the old tower survived. Interestingly, although its function changed, its painting scheme did not. It was referenced as the "old tower painted, white and red horizontal stripes" in the January 1869 *List of Light Houses, Lighted Beacons and Floating Lights of the Atlantic, Gulf and Pacific Coast of the United States*.²² It seems to have disappeared in the 1870s. Perhaps with the construction of the new Keepers House in 1873, it was no longer needed for housing, assuming the original keeper's house was still in use to accommodate the assistant keepers. There is no reference to the 1812 tower in a survey of the light station made in 1893.²³

A Storm on the Land

The Cape Lookout Lighthouse station had little time to settle comfortably into its annual routine. The State of North Carolina officially seceded from the Union on May 20, 1861, but Governor John W. Ellis had not waited. The week after the surrender of Fort Sumter on April 14, North Carolina State troops seized Fort Macon, and Ellis

²² *List of Light Houses, Lighted Beacons and Floating Lights of the Atlantic, Gulf and Pacific Coasts of the United States. Prepared by the Secretaries under a Regulation of the Light House Board, corrected to January 1, 1869.* (Washington: 1869), 33.

²³ "Cape Lookout Light Station, N.C. Reservation Surveyed 1893 by H. Bamber" (CALO Coll.) Document 623/60927 is annotated in 1906 with the approximate location of the 1812 lighthouse and cites an engineer's letter of June 22, 1858 as placing the old tower 50 yards east of the current tower.

²¹ *Ibid.*, April 25, May 5, 1860.



Figure B-9 Photo May 17, 1893, of Cape Lookout Lighthouse Station.

sent out the order to “Extinguish all harbor and other lights.”²⁴ The following week he assigned Major William H. C. Whiting to serve as inspector general to take charge of the defenses of the state. Whiting, who had been so instrumental in the construction of the Cape Lookout Lighthouse, had cast his lot with the southern cause and had been sent by Jefferson Davis to a place he knew well, the coast of North Carolina. Governor Ellis’s instructions to Whiting were clear: “Exercise the powers necessary to the public defense. Extinguish lights. Seize vessels belonging to the enemy and do whatever may seem necessary,” On April 27, Governor Ellis reported to Jefferson Davis: “All lights have been extinguished on the coast.”²⁵ That same day Lincoln extended the blockade to include North Carolina. In less than two years after its completion, war had come to the Cape Lookout Lighthouse.

²⁴ Kevin P. Duffus, *The Lost Light, The Mystery of the Missing Cape Hatteras Fresnel Lens*, (Raleigh: Looking Glass Productions, 2003), 10.

²⁵ *Ibid.*, 10-12.

Upon joining the Confederate States of America, authority over North Carolina’s lighthouses was placed under the Secretary of the Treasury, Christopher G. Memminger who in turn appointed Navy Commander Ebenezer Farrand as Chief of the Confederate Light House Bureau. On June 7, Farrand ordered that all lights be removed from the coast and taken to a place to be safely stored until the end of hostilities.²⁶

Josiah F. Bell was the Collector of Customs and Superintendent of Lights for the Beaufort District, which included the Cape Lookout Lighthouse. The responsibility, however, of actually removing and packing the complex first-order Fresnel lens structure fell to John R. Royal and his Asst. Keeper Elijah Willis, who was probably helped by machinist Asia Waters.²⁷ Superintendent Bell contracted with a local Beaufort warehouse to store the lighthouse lens and he also paid for blankets to wrap up the precious lens and for lighters to transport it from Cape Lookout to Beaufort. By June 21, the first-order Fresnel lens had been carefully removed and safely stored in Beaufort out of harm’s way. Bell summarized his response to Farrand’s directive stating, “I have in my charge all the lenses and lighting apparatus Complete, of the two lighthouses.”²⁸

Secretary Farrand’s fears were soon confirmed when Union forces first recaptured Hatteras on August 29, 1861;

²⁶ *Ibid.*, 30.

²⁷ Duffus, 32; also *Lighthouse Keepers of Cape Lookout Lighthouse 1845-1912*, National Archives Microfilm Publication Micro Copy 1373 Roll 3.

²⁸ *Ibid.*, 33.

then with the capture of Ft. Macon on April 25, 1862, Union forces consolidated control of the Outer Banks. They were soon in Beaufort seeking out the Cape Lookout Fresnel lens. The lens, however, was no longer in Beaufort but rather on a circuitous journey leading through Williamston, Weldon and finally ending in Raleigh on July 22, 1862.²⁹ There it would remain hidden until General Sherman's troops occupied the city on April 13, 1865.

Reestablishing the Light

Although Keeper Willis was retained until the end of 1861 to protect the lighthouse, seemingly little maintenance was done prior to the Union forces retaking possession. In May 1862, Brig. Gen. Parke would report that the lantern was in bad condition.³⁰

Although it was now under Union control, but without its light and without a keeper, the Cape Lookout Lighthouse remained out of service. By early December, however, the Light House Board made plans to send an illuminating apparatus for temporary use at Cape Lookout until the original lens could be recovered.³¹ By mid-February a lens was shipped and installed.³² On February 24, 1863, the lighthouse with a third-order Fresnel lens was lit; G. Chadwick was appointed keeper and the routine of lighthouse operations and maintenance resumed.³³ On March 5, 1863, District

²⁹ *Ibid.*, 100-103.

³⁰ *Index*, 22 May 1862.

³¹ *Ibid.*, 2, 9, 15, 18 December 1862.

³² *Ibid.*, 18 February 1863.

³³ Duffus, 115, footnote 114; also *Index*, 26 February 1863.

Engineer, Jeremy Smith reported on the necessity of painting the iron steps and the installation of a lightning conductor. It is possible that the "fish" shape weathervane, visible in later photographs, was installed at this point if it was not part of the original installation. More paint was requested in September.³⁴ In January 1864, 24½ yards of Holland Linen and cording was provided to the keeper to make curtains for the lantern. Cape Lookout Lighthouse was back in full operation even if its light shone less brightly.

A Daring Raid

On Sunday night, April 3, 1864, a Confederate raid under the command of L.C. Harland attempted to destroy the 1859 Cape Lookout Lighthouse, as well as the old 1812 tower. They were partially successful, but Confederate reports of the complete destruction of both were overstated. Two kegs of powder were ignited at the base of the 1859 stair, which shattered the glass, destroyed the entry-level floor and first landing, along with approximately 61 of the cast-iron steps. *The New York Times* reported on April 9 that the light would probably be out for a week. The damage to the third-order Fresnel lens must have been minor for by April 18 the *Times* reported that "the light now burns as usual."³⁵

It was not until June 27, however, that all the temporary repairs were completed.³⁶ A report filed July 28 included a drawing that

³⁴ *Index*, 5 March, 11 September 1863.

³⁵ *New York Times*, April 9, 18, 1864.

³⁶ *Index*, June 27, 1864.

illustrated the extent of these repairs and provided an inventory of the “Iron work required to renew the stairway destroyed by the rebels April 3rd 1864.” The damage to the iron stairs had been substantial. The entry-level floor plates were destroyed and required the construction of a temporary wooden floor. A wooden stair, in the form of a ship’s ladder, rose in three sections to small landings approximately twelve feet apart. At the third landing, it extended up an additional four steps to engage the remaining iron stairs. In all, the request was made for 61 replacement iron steps, 6 lower floor plates and 3 landing plates.³⁷

Although the Union Commanders reported the attack as unsuccessful, the *Times* noted, “The attempt was exceedingly audacious, as the locality is far within our lines.” It was an embarrassment and Rear Admiral S. P. Lee, Commander of the North Atlantic Blockading Squadron, sent a request six days later to Major General Butler, U. S. Army “that a sufficient force be assigned to guard this important lighthouse to prevent any repetition of such attempts.”³⁸ It was an event not soon forgotten. Over a year later, in June 1865, a full month after the capture of Jefferson Davis and the end of the Confederacy, correspondence was generated

³⁷ “Cape Lookout L. House N.C., Temporary repairs wooden in Indian yellow, Drawn by G. Castor Smith, Actg. Engr. 4th L.H. Dist. From measurements etc by Jere P. Smith;” also see *Index*, July 28, 1864.

³⁸ Official Records of the Union and Confederate Navies in the War of the Rebellion.

Series I – Volume 9: North Atlantic Blockading Squadron, May 5, 1863- May 5, 1864. (Washington: Government Printing Office, 1899), 956.

“reporting the whereabouts of leader of Raid against [the Cape Lookout Light Station]”³⁹

Recovery of the Fresnel Lens

As early as May 1862, Brigadier General Parke had reported the removal of the Cape Lookout lens to Raleigh; getting to it would take three more years.⁴⁰ With General Sherman’s capture of Raleigh on April 13, 1865, came the recovery of the Fresnel lens. Lt. George Round, who was assigned to establish a signal post on the Capital’s Montgomery Meigs wrote, “I learned that some broken prisms or portions of lenses have been seen in possession of boys in the streets,”⁴¹ On November 17, 1865, the Light House Board decided to return the damaged lens to Paris for repairs. The Cape Lookout lens was among the first to be sent to France on November 28, generating the following memorandum from the Board Chairman, Adm. William B. Shubrick, to Lemonnier, Sauter and Company indicating the condition of the lens:

Gentlemen: I have to request that you will make as soon as convenient the following described parts of illuminating apparatus. Upon completions of the work, it should be securely packed, marked “Lighthouse Apparatus,” and shipped to the Collector of Customs, New York City, United States, who will pay your bill.

³⁹ *Index*, June 13, 1865.

⁴⁰ *Ibid.*, May 22 1862.

⁴¹ *Ibid.*, 142.

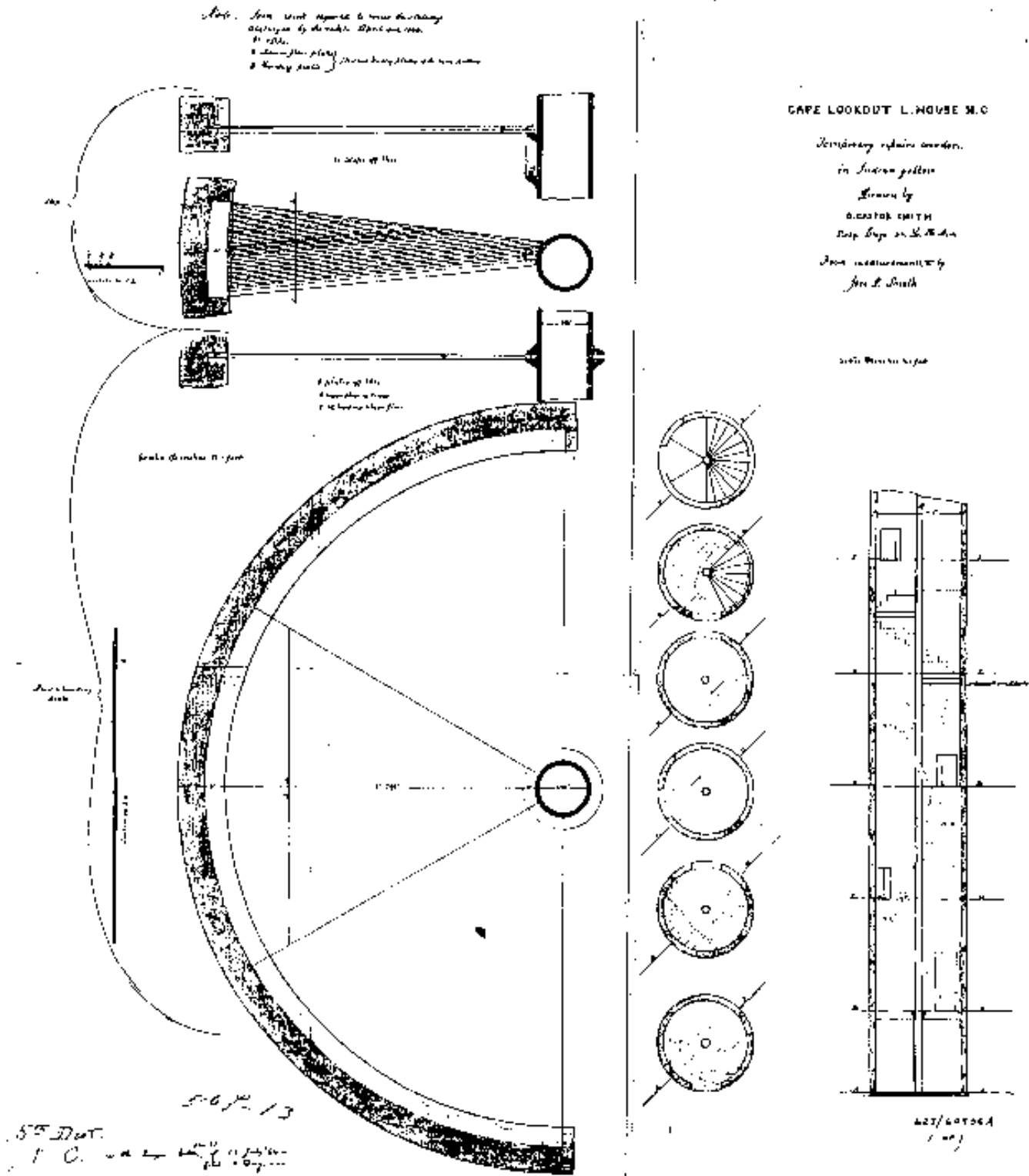

Figure B-9 1864 Drawing of damage and repairs by G. Castor Smith, Archives Cape Lookout National Seashore.

*1. First-order, fixed 270 degrees – Cape Lookout, Lens to be retrofitted with sound prisms in place of the 17, which are badly chipped. Astragals, horizontal rings, Crown for lens, Socket, pedestal Table, lockers, balustrade & Wagner Lamps.*⁴²

In mid-August 1866, the ship *Gettysburgh* returned the perfectly restored lens to Staten Island.

Post War Repairs

Repairing the lens was only part of the challenge in returning the Cape Lookout Light to top operational condition. An assessment of the conditions at the lighthouse in early 1866 resulted in the recommendation to place a lightship off the point of the shoals. The light from the third-order lens was simply insufficient.⁴³ Acting Engineer Jere P. Smith's report with G. Castor Smith's drawing of 28 July 1864 had provided an illustration and inventory of the repairs required. It was not until November 1866 that funds for the iron stairs were appropriated. That same month, 5th District Engineer, W. J. Newman filed his requisition for an "Illumination apparatus – 1st order."⁴⁴

Repairs were probably made the first part of 1867 for by 18 March, Newman recorded that "Cape Lookout LH NC reported ready to receive 1st order lens." On March 19, 1867, Light House Board Chairman William B. Shubrick directed:

*You will please forward as soon as possible to W.J. Newman, Esq., Acting L.H. Engineer, Baltimore Maryland, the first-order apparatus marked L.H.B./L.S. 215-242, recently repaired in France and now in storage at the Staten Island Depot, sending with it all the necessary accessories and supplies of an apparatus of that class, except oil and oil butts. The apparatus is intended for use at Cape Lookout to replace the third-order lens now there.*⁴⁵

The original lens was probably reinstalled by the end of May and by August the third-order was returned to the Lighthouse Board.⁴⁶

In 1869, with a keeper and assistant keeper on station, repairs were made to the dwelling, and the lantern was given two fresh coats of paint. The Cape Lookout Lighthouse Station was reported to be in good order.⁴⁷

1873—A New Look

1873 was a significant year for the Cape Lookout Lighthouse Station. A major expansion occurred that year with the construction of the Keeper's Dwelling. It seems certain that the original keeper's dwelling, which had been extensively repaired in 1869, still remained. It is at about this time that the modified 1812 tower disappeared from the records. As part of the

⁴² Ibid., 153.

⁴³ *Index*, March 27, April 11, 1866.

⁴⁴ Ibid., November 19, 30, 1866.

⁴⁵ Duffus, 155.

⁴⁶ *Index*, May 21, August 29, 1867.

⁴⁷ *Report of the Light-House Board, 1869*. compiled by Beckman, E.J. 2006. (CALO Coll.).

1873 upgrade, an oil room was constructed, a bell line was run from the house to the tower's lantern, and a stove was placed in the Watch Room.⁴⁸ It was in the spring of that year, however, that the most dramatic visual change occurred. The directive from the Lighthouse Board was clear:

*Cape Hatteras tower will be painted in spiral bands, alternatively black and white. Cape Lookout tower will be checkered, the checkers being alternately black and white. Body's [sic] Island tower is now painted black and white horizontal bands.*⁴⁹

As early as February a sketch had been prepared showing a painting scheme that would differentiate the Cape Lookout during daylight hours from its sister Outer Banks lighthouses.⁵⁰ By mid-April, 5th District Engineer Major P.C. Hains "transmits copy of *Notice to Mariners* of painting [and] requests advertisement."⁵¹

The use of diagonal checkers rather than horizontal gives the tower its unique appearance among all North American lighthouses. Because the tower is the frustum of a cone, with the diameter considerably smaller at the top, the geometry of checkers would be challenging, applied in any direction. The horizontal

squares would have to be trapezoidal, that is, slightly larger at the bottom than top. Cape Henry Lighthouse, Virginia, would execute a horizontal checker pattern in 1881 and continue northward the black and white patterns used on the lighthouses of the North Carolina Outer Banks.

The diagonal pattern of Cape Lookout allows for diminishing square size with the rise in elevation. The corners are not right angles so the squares become diamond shaped. Even so, these diamonds lack symmetry as the top two sides are shorter than the lower two sides. Unlike the spirals of Hatteras or the bands of Bodie, this diagonal pattern had the advantage of creating distinct sides. This appears to have been the intent and was used to advantage by marking the North and South elevations with the black fields dominant and the East and West elevations with the white fields dominant.⁵² Whether this day marking was intended to assist in directional identification is unknown, but this distinctive detail gave a level of complexity and sophistication in marking not seen elsewhere. The identity of the actual craftsman who executed this pattern for the first time on the building is not certain, but Maj. P.C. Hains was the 5th District Engineer and Manaen W. Mason was the keeper on station at the time.

For the next couple of decades, the station seems to have settled into an operational routine. There was an incident in 1875 when the light was temporarily extinguished that

⁴⁸ *Index*, January 29, February 5, 1873.

⁴⁹ Herbert W. Stanford III, *Cape Lookout Lighthouse and Its Environs: Guide for Cape Lookout Lighthouse Volunteer Keepers*, (Washington: National Park Service, Cape Lookout National Seashore, 2008), Chapter 2, 6.

⁵⁰ *Index*, February 17, 24, 1873.

⁵¹ *Ibid.*, April 15, 1873.

⁵² *Ibid.*, April 17, 1873.



Figure B-10 Comparison of 1881 Cape Henry, Virginia, and 1859 Cape Lookout, North Carolina

may have led to the removal of the Keeper Mason and his two assistants the following year.⁵³ The tower was painted at least once.⁵⁴ Major efforts seemed to be made to extend the warning zone by placing a lightship on the shoals or making the light

⁵³ Ibid., January 7, 17, 1874; August 19, 1876.

⁵⁴ Ibid., July 10, 1885.

more powerful.⁵⁵ The nineteenth-century ended with one of the most destructive storms to hit Cape Lookout. Telegraph and telephone service, installed just a year earlier assisted in communication. Although the lighthouse station weathered the storm, the *San Ciriaco* or “Great hurricane” of August 17-18, 1899, destroyed Shackleford Banks and drove much of the population permanently across the sound.

Improving the Light

The use of the Fresnel lens revolutionized the transmission of light from the tower. This device, which so effectively concentrated and directed the light, remained in service even while efforts were continually being made to improve the light source itself. Initially sperm whale oil was used to fuel the lamps in Cape Lookout’s first-order lens. By late 1883, mineral oil was introduced as a fuel.⁵⁶ The problem of brightness remained. The *United States Coast Pilot* reported in 1895 that the light was visible at slightly over eighteen nautical miles, but because of the expansive shoals the “Cape Lookout Light will not be sighted unless on a very clear night.”⁵⁷ In 1912, an incandescent oil vapor lamp was installed in the lighthouse.⁵⁸ In order to create a more powerful light, three burners with a cluster

⁵⁵ Ibid., March 11, 1892; July 15, 1893; December 8, 1897.

⁵⁶ Ibid., December 26, 1883.

⁵⁷ United States Coast Pilot: Atlantic Coast. Part VII, From Chesapeake Bay Entrance to Key West (Washington: Government Printing Office, 1895), 12, 34.

⁵⁸ Stanford, 1-7.

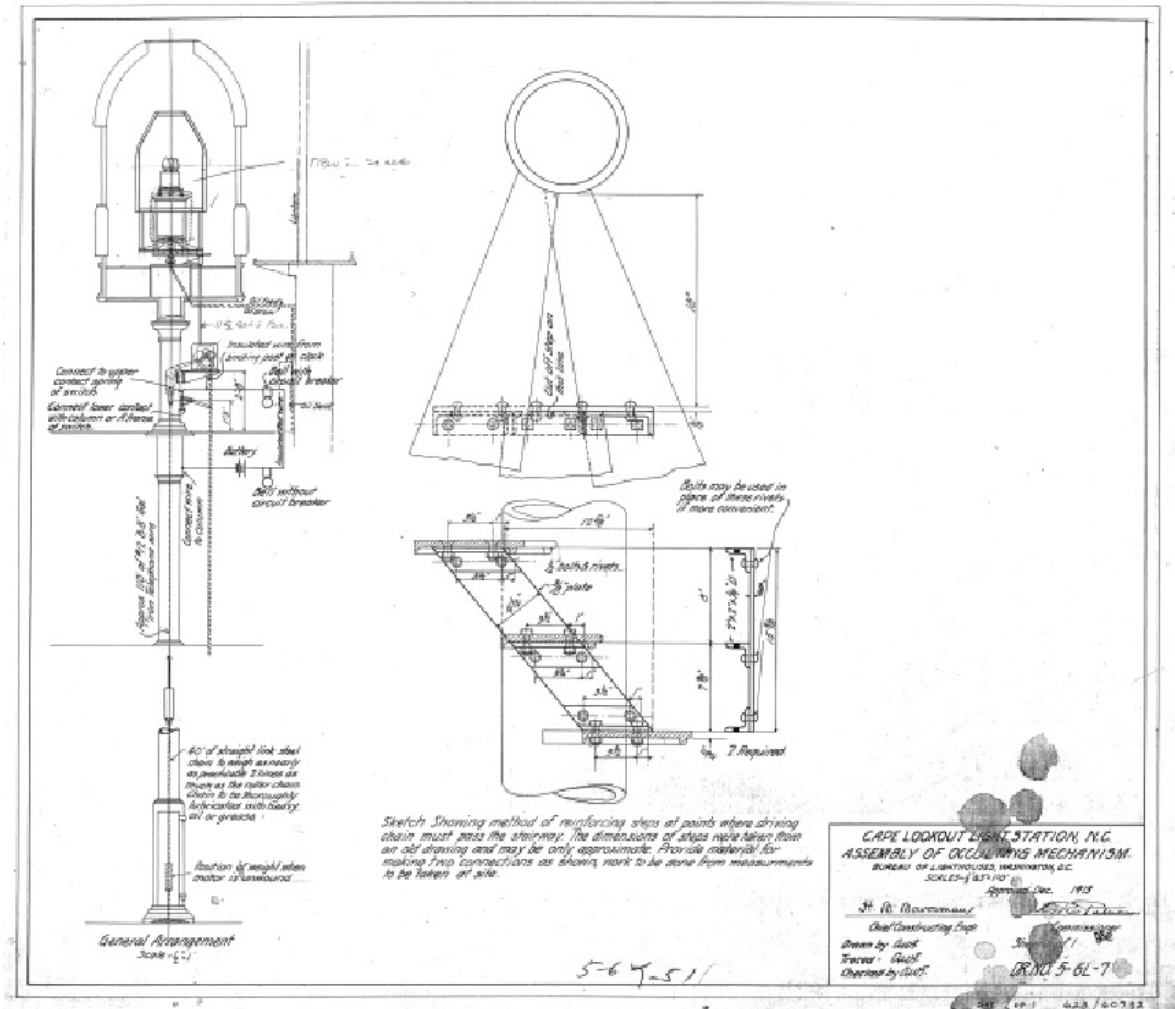

Figure B-12 Image of Occulting Device, Archives Cape Lookout National Seashore.

of three mantles were used.⁵⁹ None of these changes in fuel or wicks, however, radically altered the physical structure of the lighthouse lantern itself.

Since it was first established in 1812, Cape Lookout had been a fixed, white light station, meaning the light did not flash.

⁵⁹ George R. Putnam. *Lighthouse and Lightships of the United States* (Boston: Houghton Mifflin Co., 1917), 187-188; also <http://books.google.com/books?hl=en&id=UNM3AA AAMAAJ>

Although a flashing light might not be visible at a greater distance than a fixed light, it did establish a signature pattern which differentiated the lighthouse light from other shore lights and assisted in location identification.

In 1913, plans were made to install an occulting device at Cape Lookout. When completed in February 1914, the light had two eclipses, each of ten seconds.⁶⁰ The

⁶⁰ Putnam, 98.

mechanism was weight driven using the hollow center of the cast-iron stair column as a chase for the weights. It was geared much like a clock except it turned a shield assemblage that was located between the light source and the lens. In order to accommodate the drive chain, a hole was cut in the Watch Room deck and two cast-iron steps were cut to allow the chain to pass through. In this mechanism, the shields were aluminum, probably highly polished to enhance the light's intensity.⁶¹

The alteration was a documented success. "The importance of a distinguishing characteristic is well illustrated in this case. In the two and one fourth years before the change, five wrecks were reported, in which the cause was stated to be the mistaking of the Cape Lookout Light for some other light. For the same interval since, there has been no report of a wreck from this cause."⁶²

Storm Door and Air Lock

In 1913-1914, probably in an effort to isolate and protect the incandescent oil vapor lamp and the new occulting mechanism, major renovations were made in the Service Room and the Watch Room gallery to create air locks. The 1859 gallery with its railing was totally replaced and enlarged from 2½ feet to 4 feet resulting in a noticeable overhang. The new deck was

created by filling the four-inch deep cast metal pans with concrete re-enforced with five runs of half-inch diameter bars. On this concrete, new 1½-inch pipe rails with 2-inch pipe posts replaced the wrought iron railing. A goal of this enlargement appears to have been to provide enough space to construct a protective enclosure in front of the exterior doorway into the Watch Room. This 5 feet by 3 feet 4¾-inch room was made of metal plates bolted and riveted together. For light and ventilation there was a single four-light window sash hinged on the top to open. Unfortunately, it appears that the new pipe railing would keep this window from opening fully. With a solid metal door on just one end, the enclosure effectively blocked circumnavigation of the gallery. It did, however, provide a tightly sealed space to protect the wooden door from wind and water.⁶³

In the Service Room, below the Watch Room, an existing partition was reworked with the joints being made air tight with oakum or putty. A small airlock was constructed in the Watch Room, though it barely fit into the space at the foot of the stair, to block the updraft in the tower.⁶⁴ These two alterations created a much more tightly controlled environment in the Watch Room and Lantern.

⁶¹ E.J. Edwards and H. H. Magdsick, "Light Projection: Its Application." in *Illuminating Engineering Practice, Lectures on Illuminating Engineering Delivered at the University of Pennsylvania, September 20-28, 1916* (New York: McGraw-Hill Book Co. 1917), 243; also <http://books.google.com>

⁶² Putnam, 98.

⁶³ "Cape Lookout Light Station, N.C. Storm Door & Parapet Floor, Bureau of Lighthouses, Washington, DC, Sept. 10, 1913." (CALO Coll.)

⁶⁴ "Cape Lookout Light Station, N.C., New Air Lock & Repairs, Bureau of Lighthouses, Washington, DC, Sept. 10, 1913." (CALO Coll.)

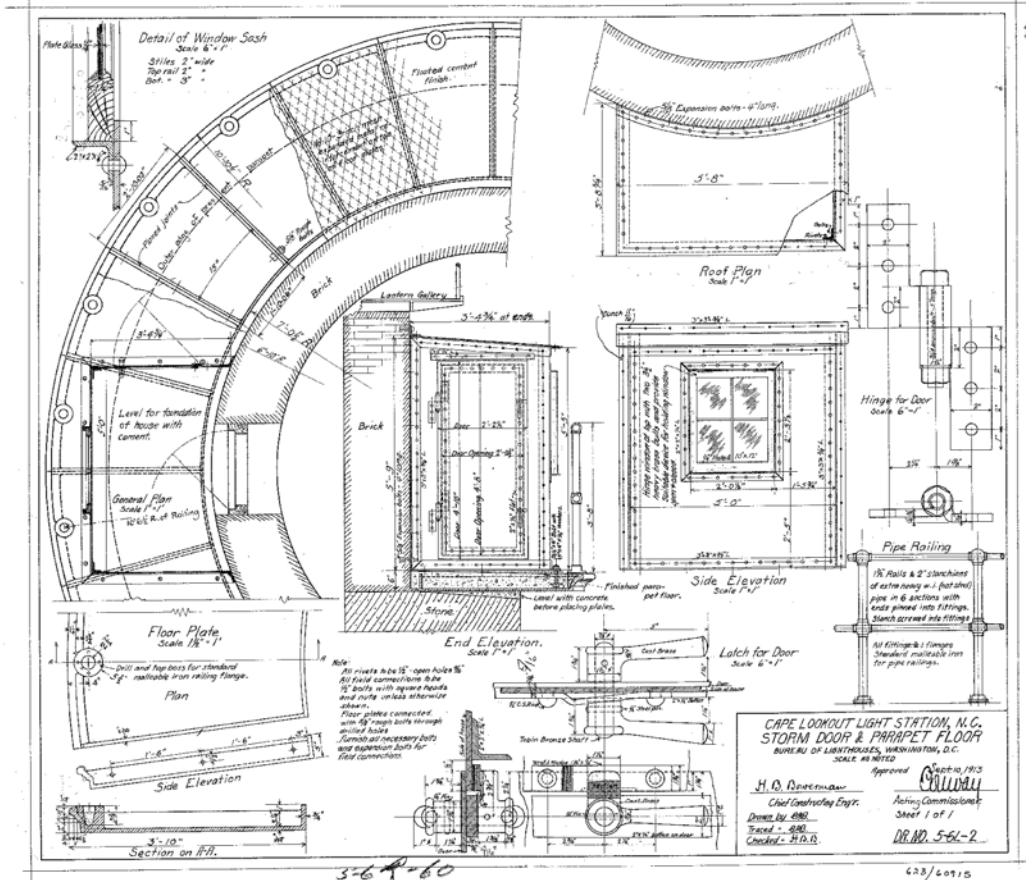

Figure B-13 Drawing of Air Lock.

In 1933, the 1907 summer kitchen building was converted into the radio shack and battery house for use. A radio tower was constructed in front of the building and a single wire antenna was run to the Watch Room gallery. Two conduits with no. 8 Park cable were run from the engine and battery house out to the tower bringing electric lighting to the lighthouse. The October *Lighthouse Service Bulletin* reported that:

The installation of a radiobeacon and electric lighting equipment at Cape Lookout light Station was

completed on August 15. The outfit consists of 2 gasoline engines direct connected to 5 kw generators, 2 sets of 200-ampere lead-acid storage batteries and two 200-watt transmitters with the necessary operating devices.

The 75-millimeter incandescent oil vapor lamp in the tower has been replaced with four 250-watt T-14 lamps, increasing the candlepower from 77,000 to 160,000. The antenna is suspended between the light tower, about 150 feet high,

and an 80-foot steel tower adjacent to the radio building, the distance between the two being approximately 210 feet.

The entire radio beacon equipment including the storage batteries was that removed from Lightship No. 72, and the new equipment purchased consisted only of generator sets, wire, cables and conduit.⁶⁵

With the installation of new electric light mechanism came a new flash pattern.



Figure B-14 Attachment location for radio antenna.

Working on a 15 second cycle, the light was on for 2 seconds, eclipsed for 2 seconds, on again for 2 seconds and eclipsed for 9 seconds.⁶⁶

⁶⁵ *Lighthouse Service Bulletin* Vol. IV No. 46. October 1933. Transcribed by Cheryl Roberts in email to Karen Duggan, Cape Lookout National Seashore, 4 June 2006.

⁶⁶ *Lighthouse List South Atlantic Coast of the United States 1937*, U.S. Department of Commerce, Lighthouse Service. 1937, 22. Also, *U.S Coast*

Although the candlepower more than doubled, navigators were no longer reliant solely on spotting the light. Cape Lookout Light Station now broadcast a radio signal group of dash-dot-dash-dot for 60 seconds followed by a period of silence for 120 seconds.⁶⁷ This was the first of a series of electronic signals and devices, culminating in the satellite Global Positioning System (GPS) that significantly reduced the reliance on a light.

The following month, on September 15, a hurricane struck the cape and opened Barden Inlet to the west of the lighthouse thereby creating Shackleford Banks. The inlet has been sustained over subsequent years by dredging. Although it is a boon to boaters and local fishing, it has created a new threat to the lighthouse as erosion on the inlet side moves the shoreline toward the station.

The United States Lighthouse Service was discontinued in 1939. Its equipment and personnel were transferred to the United States Coast Guard. With the arrival of World War II, Cape Lookout witnessed the tragic loss of shipping to the German operation called *Paukensschlag* (drum roll). With little defense in place and the shoreline still illuminated, German submarines wreaked so much havoc during the first half

Guard Light List, Volume I, Atlantic Coast, 1973, 23. (CALO Coll.)

⁶⁷ *United States East Coast North Carolina Cape Lookout to New River*. Map by Department of Commerce, Office of Coast Survey/National Ocean Services. 1932; also http://historicalcharts.noaa.gov/tiled_jpgs_done/zoomifyURLDrivenWebPage.htm?zoomifyImagePath=1234_12-1932. (16 July 2008).

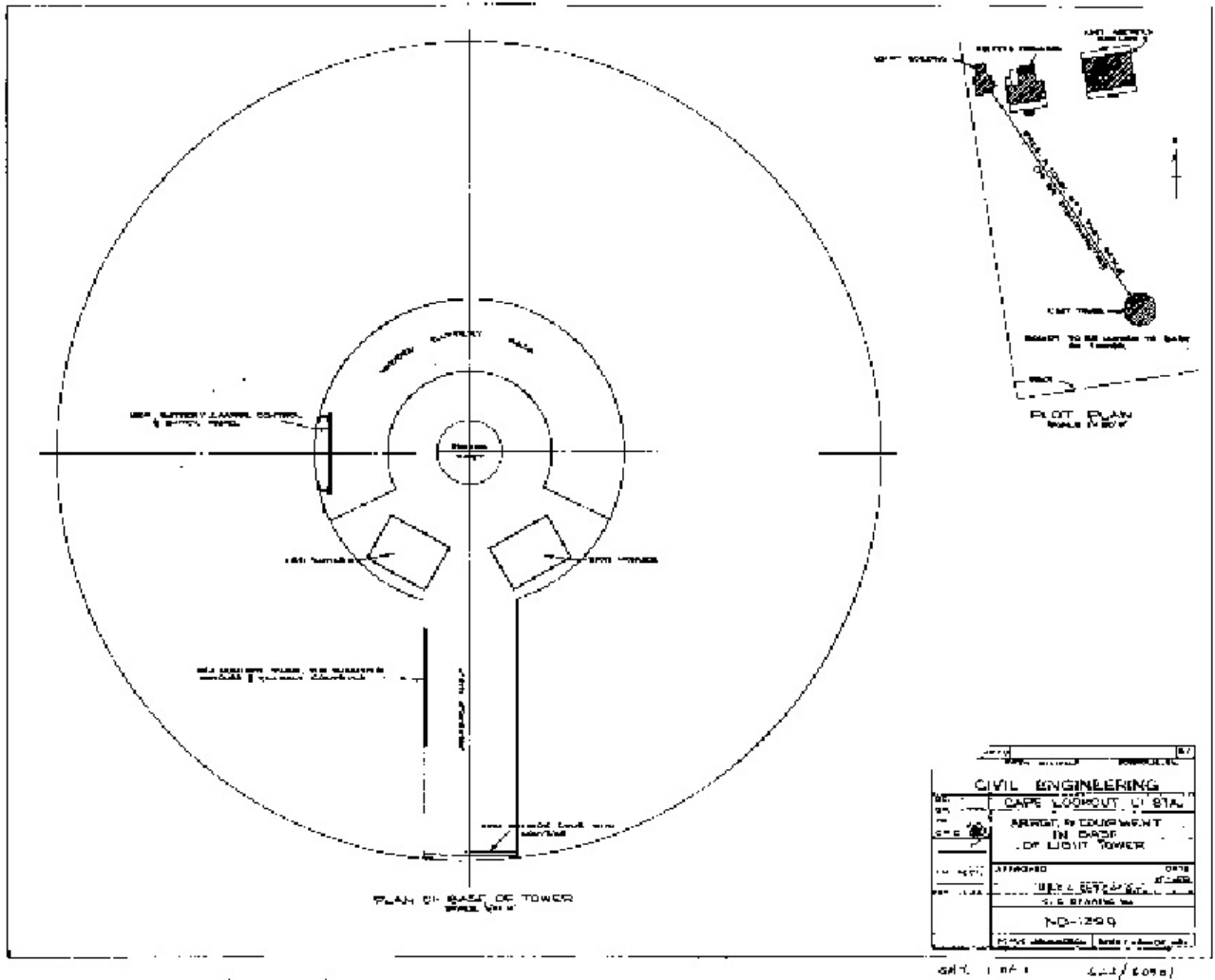

Figure B-15 Plan of 1950 electrical service installed in first floor. Archives Cape Lookout National Seashore.

of 1942 that the Atlantic coast became known as “Torpedo Junction.”

In mid-March the Cape Lookout Light was still continuing its bright sweep, silhouetting the ships and making them vulnerable to attack. By June, however, the coast had been darkened.⁶⁸ The lighthouses continued to serve as observation points to look for submarines and saboteurs. After the war,

⁶⁸ Homer H. Hickman, *Torpedo Junction* (Annapolis: Naval Institute Press, 1989) 84, 290.

Cape Lookout continued its upgrade of radio signaling devices with the erection of new towers near the lighthouse.⁶⁹ Electronic broadcast was the way of the future.

The Coast Guard continued to maintain the tower and modernize its operation. In 1950, the Coast Guard retrofitted the ground level of the tower into an electrical room. Inside were placed two 2RVI Kohler generators,

⁶⁹ *Cape Lookout LT. STA.N.C. Alterations to Radio Installation*, January 26, 1949. (CALO Coll.)

wall-mounted control panels and a rack to hold the batteries. The cable connections the old engine and battery house were disconnected.⁷⁰ At this point the lighthouse became self-contained and fully automated, no longer requiring the presence of an on-site keeper. The light would continue to be powered in this manner until 1982, when electric cables were run from Harker's Island.

During the 1950s and early 1960s the U.S. Coast Guard had less and less use for the station's buildings. Several structures were demolished and the 1907 Keepers House was moved. One development plan in 1962 proposed the relocation of the Life Boat Station to the lighthouse site and called for the demolition of everything on the site except for the tower.⁷¹

Becoming Part of the National Park Service

In 1966, another branch of the U.S. government began its involvement with the Cape Lookout Light Station. Act of Congress P.L. 89-366 authorized the creation of Cape Lookout National Seashore. On October 18, 1972, the station "consisting of the lighthouse, the keeper's dwelling, a generator house, a coal and wood shed, and a small cement block oil house—all situated on a long narrow sandy island called Core Banks" was placed on the

National Register of Historic Places.⁷² In 1976, Cape Lookout National Seashore was established with headquarters in Beaufort. The U.S. Coast Guard, however, retained control of the lighthouse site. In 1982, the Cape Lookout Coast Guard Station was decommissioned and its function merged with the station at Fort Macon. In 1984, the station's property and buildings were transferred to the National Park Service. The Coast Guard continued to retain possession of the lighthouse itself.

Removal of the Fresnel Lens—Again

During the earliest phase of this gradual shift in ownership, around 1976⁷³ or approximately one hundred and ten years after the first-order Fresnel lens had been reinstalled in the Cape Lookout Lighthouse, it was removed in the quest to get a brighter light. This time the U.S. Coast Guard chose to replace the historic lens with two powerful 24-inch aero-beacons generating 800,000-candle power each. These rotated and created a flash pattern of every 15 seconds, which continues to be the pattern. The Lemmonier-Sauter lens was relocated to 5th District Coast Guard Headquarters and used as a monument decorating the entrance to the Mess Hall and Base Exchange. Then in 1994, it was moved again and installed in the newly relocated and renovated Block

⁷⁰ "Cape Lookout Lt. Sta. Arrgt. of Equipment in Base of Light Tower" May 1950. (CALO Coll.)

⁷¹ "Cape Lookout L.B.S. Relocation of Station Preliminary, U.S. Coast Guard Fifth District, Portsmouth VA. Civil Engineering, July 27, 1962" (CALO Coll.)

⁷² National Register of Historic Places Nomination: Cape Lookout Light House, NC. (Raleigh, NC: North Carolina Division of Archives and History, Department of Cultural Resources, 1972).

⁷³ The exact date remains undocumented; Duffus gives a date of 1967 (190) which maybe a number reversal. Dated photograph (slide #1030) in the CALO archives document the change as occurring prior to October 1977, the National Register nomination indicates the lens in place in 1972.

Island Southeast Lighthouse off the coast of Rhode Island. There it remains today, notwithstanding various efforts to have it returned to Cape Lookout.⁷⁴

Shoring the Interior

The most significant alteration made to the upper part of the tower since the 1914 gallery enlargement or the removal of the Fresnel lens ca. 1976 occurred in 1989. By 1988, it was clear that above the eighth floor both the ironwork and the masonry had seriously deteriorated. The eighteen inch thick masonry between the eighth and lantern floors had developed severe vertical and horizontal cracks, some of which were over one inch wide. Six vertical cracks completely penetrated the wall and ran the full height. One horizontal crack ran the full circumference and portions of the wall had shifted. It was feared that the structure would collapse in the event of a 130 mph hurricane. One option studied was to encase the wall in steel but ultimately, in order to address concerns over the structural stability of the lantern, watch and service levels, the Coast Guard embarked on a major shoring and stabilization project. The work also included the replacement of the railings on both the Lantern Room and Watch Room galleries. The new posts for the upper gallery extended through the original iron floor plate of the Lantern gallery, through some new horizontal framing then anchored in the floor of the Watch Room gallery. On the interior, a series of metal diagonal cross bracing and horizontal framing lace the

⁷⁴ Duffus, 190.

walls of the upper part of the tower. This resulted in the cutting of several of the original cast-iron steps and removal of part of the service-level partition wall.⁷⁵

Although acknowledged not to be aesthetically pleasing, it was believed to provide better protection against failure and cost less than the steel encasement option. Seven years later on September 5, 1996 it would be tested with Hurricane Fran.

Continuing Maintenance

A general inspection of the building was made in December 1992. The inspector noted that the building had been “recently painted (summer 1992)” and that “windows replaced summer 1992.”⁷⁶ He noted the structural shoring but also called attention to a moisture problem resulting in mold on the walls and rusting of the stairs. Clearing the ventilation ball and vents of bird and insect nests to improve air flow was the only recommendation. The inspector noted that the electronics package was on the second level and the generator on the lower level and that “Each of these levels are now separated with a false floor installed, whereas previously access to the entire

⁷⁵ *Lighthouse Stabilization, Cape Lookout Lighthouse, Cape Lookout, North Carolina*. U.S. Coast Guard Shore Maintenance Detachment, Cleveland, Ohio. 1988. 7 Sheets: 1. Lighthouse Details, 2. Section and Rail Details, 3. Frame Section, 4. Frame Details, 5. Frame Details, 6. Latern [sic] Frame Details, 7. Reference Drawing. Copy placed with Cape Lookout National Seashore, Harker’s Island, NC.

⁷⁶ Cape Lookout Light (LLNR 575) Station Structural Inspection Sheet, 17 December 1992. Copy placed with Cape Lookout National Seashore, Harker’s Island, NC.

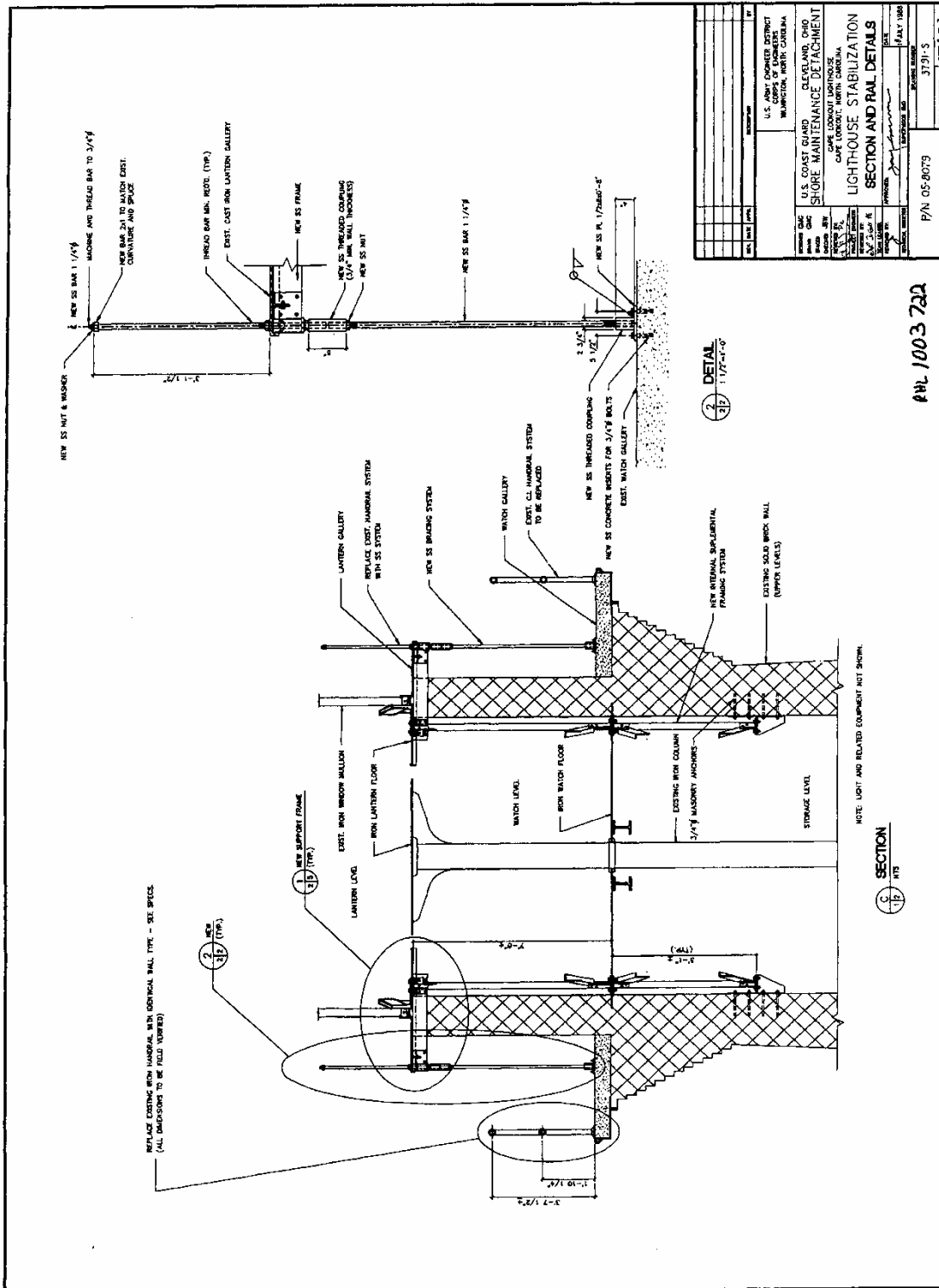

Figure B-16 1989 section of shoring of Gallery.

structure was from the generator area.”⁷⁷ Currently one of the pie-shaped metal plates has been slid aside and replaced with a steel plate, indicating the possible location of a connection between the two levels. The inspector also noted that the wiring was old and frayed and the fuse disconnects in poor condition. Further, the condition of the room housing the air-cooled generators was not ideal with poor ventilation and awkward 90-degree elbows in the exhaust piping. Little corrective action was taken, for these conditions were again recorded in an inspection conducted May 4, 1993. The May 15, 1995 inspection noted the excessively chalky condition of the paint and that the “Door at 3rd level leading out to the cat walk is corroded and hinges broken. This will be replaced and fixed by Group Eng. this summer.”⁷⁸

In 1996, the Coast Guard commenced a major electrical upgrade in the tower. Work included the main electrical wiring, junction boxes, the emergency beacon system and a variety of controls and support devices. In the spring of that year, American Lighthouse Restoration Company completed the repainting of the exterior of the building.

On 14 March 1997, U.S. Coast Guard Civil Engineering again inspected the lighthouse. They remarked that the exterior had been painted in the spring, the two windows blown out by Hurricane Fran had been

boarded up and that an electrical upgrade was in process. Of concern was the deterioration of the interior masonry and the windows. The moisture had deteriorated mortar joints and loosened some of the steps. The moisture was again noted in the lantern room with rust and mold growth. It was anticipated by the Coast Guard in 1997 that “This lighthouse will most likely continue to be needed through 2010. The lighthouse could possibly be either transferred to the National Park Service and/or be outgranted to a lighthouse preservation group; these options are not being currently being pursued.”⁷⁹

In anticipation of continuing to operate the lighthouse, the Coast Guard undertook what turned out to be their last major investment in the Cape Lookout Lighthouse in 1999. The ten wooden windows were replaced and new metal storm doors for the first- and second-floor entrances installed. At that same time, the interior walls were water blasted and approximately 1,075 square feet of masonry was repointed and repaired to include resealing the stairs to the brick wall. Lightning protection was installed. Exterior painting was limited to around the window and door installations.⁸⁰ In June of the following year the exterior was repainted.

⁷⁷ M.E. Clark, *Trip Report Outer Banks, N.C.* December 1992. 5. Copy placed with Cape Lookout National Seashore, Harker’s Island, NC.

⁷⁸ Biennial Lighthouse Inspection report, Fifth District, Cape lookout light, LLNR 670, May 15, 1995 by ENS Josh Peters.

⁷⁹ Untitled information sheet from Coast Guard archives in Cleveland with notation “Options classified as likely are reflected in long term plan. Information current as of 10/1/97.”

⁸⁰ *Cape Lookout Light Repairs Cape Lookout NC Elevations and Details*, March 3, 1999. Civil Engineering Unit Cleveland. (CALO Coll.)

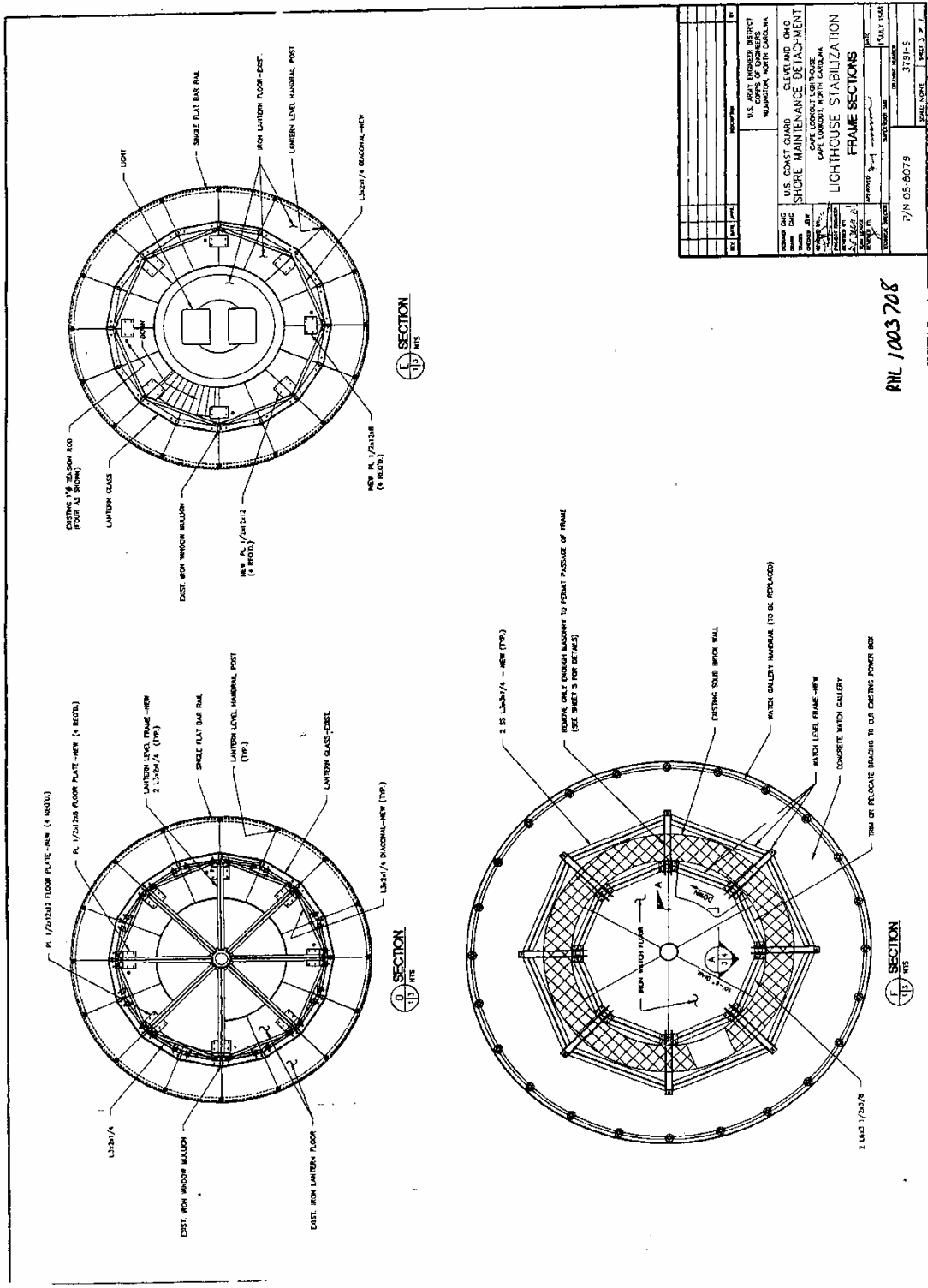

RNL 1003708

Figure B-17 Plan view of 1989 shoring in tower.

National Park Service Assumes Control

The transfer of the Lighthouse to the National Park Service came sooner than was first anticipated in 1997. While retaining operational control of the upper levels, the Coast Guard turned the lighthouse over to the Park Service on June 14, 2003.

In early 2004, the Coast Guard solicited public comment about the quality and usefulness of the light. The January issue of *Lighthouse Digest* stated, “Hopefully, these questions will not mean the light will be removed from the tower.”⁸¹ Chief Warrant Officer Chris Humphrey who was in charge of the survey found concern over the condition of the submerged cable. Under consideration was the possibility of a conversion to solar power. He reported they had received a few phone calls, “all from non-mariners that just like to sit at the waterfront and watch the light.” Clearly the Lighthouse had become an important local attraction as much as a navigational aid.⁸²

In October 2004, High Structure Maintenance, LLC (formerly American Lighthouse Restoration Company) repainted the lighthouse using Valspar paint donated by Lowes.⁸³

The erosion on the inlet side of the island caused by Barden Inlet became increasingly

threatening. In September 2003, only a few months after the National Park Service had taken over control of the lighthouse, Hurricane Isabel struck and eroded the protective dunes on the sound side and destroyed the coal shed. By 2006, the erosion required intervention if the site was to be preserved. In January, the Park Service announced a program to replenish the sound side beach with sand dredged from a shoal northeast of Shackleford Banks.⁸⁴ The station remains particularly vulnerable from sound-side erosion.

As the lighthouse approached its anniversary, 150 years of age began to take their toll. On June 14th and 15th 2003 the light house was opened to the public as part of the transfer ceremony. Since then, it has been opened for public viewing an average of four days a year. Unprecedented crowds have visited with more people ascending the tower in a matter of a few days than had done so in the hundred years before. Its popularity as a primary attraction and signature for Cape Lookout National Seashore was quickly proven but the impact and sustainability of this new intense use required examination. On February 28, 2008, Cape Lookout National Seashore Superintendent Russel J. Wilson issued a press release that stated “tours of the Cape Lookout Lighthouse have been suspended for public safety reasons...an engineer’s inspection conducted this month revealed significant deterioration to the integrity of the tower’s circular stairway.” He went further to say that the program of work for

⁸¹ Timothy Harrison, Keepers Korner: “How Bright Is Cape Lookout?” *Lighthouse Digest*, January 2004.; also http://www.lighthousedepot.com/lite_digest.asp?action=get_article&sk=1863 (12 July 2008)

⁸² Humphrey, Chris. “RE: Cape Lookout Light House” E-mail to author 10 July 2008.

⁸³ Horak, Nadeene. “RE: Cape Lookout Lighthouse” E-mail to author 7 July 2008.

⁸⁴http://www.nps.gov/caloparknews/02_17_2006b.htm. (6 July 2008).

the summer "...will include a comprehensive engineering evaluation and design work for the modifications that are necessary to the lighthouse to ensure public safety." ⁸⁵Thus, the Park Service commenced an all-inclusive study as the first step to assure the long-term preservation of the historic Cape Lookout Lighthouse.

⁸⁵http://www.nps.gov/cal/parknews/02_22_2008.htm. (6 July 2008).

TIMELINE

- 1804 Mar. 26 Congress authorizes light station at Cape Lookout.
- 1805 Feb. 18 Four acres purchased for light station.
- 1812 First lighthouse constructed.
- 1830 May 3 Elijah Pigott *et. al.* execute deed for eleven additional acres to expand station to fifteen acres.
- 1851 Mar. 3 Congress commissions study of lighthouses.
- 1852 U.S. Light House Board established.
- 1857 Mar. 3 Funds approved to construct new lighthouse at Cape Lookout.
- 1858 Apr. Foundation borings begin on second Cape Lookout Lighthouse.
- 1859 Feb. Request made for a clock.
- Nov. 1 Second Cape Lookout Lighthouse begins operation.
- 1860 1812 Light House tower converted to keeper's quarters.
- 1861 Apr. Confederates seize lighthouse.
- May 20 North Carolina joins Confederacy, puts out lighthouse lamps.
- June First-order lens removed by Confederates and stored in Beaufort.
- 1862 Apr. Union Army captures Ft. Macon, regains control of Outer Banks.
- 1863 Feb. 24 Third-order Fresnel lens installed, and light relit.
- 1864 Apr. 3 Cape Lookout Lighthouse damaged by Confederate raid.
- June 27 Temporary repairs to steps, landings and glass completed.
- 1865 Apr. 13 First-order Fresnel lens recovered in Raleigh.
- 1866 Congress authorized \$20,000 for the repair.
- 1867 Civil War damage repaired.
- May First-order Fresnel reinstalled, mariners notified of renovation.
- 1869 Lantern painted with two coats, inside and out.

- 1873 New brick Keeper's Quarters completed; possible date demolition of original lighthouse.
- 1873 Apr. Frustum painted in black and white diagonal checker pattern, lantern remains black.
Bell line connects house and tower, stove added to Watch Room.
- 1876 Mar. Signal Service begins occupying 1812 Keepers House to operate weather station and telegraph line.
- 1883 Dec. 26 Mineral oil introduced as fuel.
- 1885 Mar. Receive a shipment of Lard oil.
July Painting tower.
- 1887 U.S. Life Saving Station established 1½ miles SW of lighthouse.
- 1888 Notice to Mariners ref: change in light characteristics.
- 1898 May 18 Telephone installation at lighthouse station connecting to Beaufort telegraph station.
- 1899 Aug. 17-19 *San Ciriaco* or "Great hurricane" destroys Shackleford Banks.
- 1910 June 17 Bureau of Lighthouses (Dept. of Commerce) replaces Light House Board (Dept. of Treasury).
- 1912 Incandescent Oil Vapor lamp installed in lighthouse.
- 1914 Feb. Light changed from fixed to flashing.
Watch Room gallery (also called Observation Deck) enlarged. Storm Room added to the gallery, partition wall rebuilt with air lock to the Service Room below Watch Room.
- 1916 Construction begins on new Coast Guard Station.
- 1917 June 12 Congress appropriated \$300,000 to enable the U. S. Coast Guard to extend its telephone system to include all Coast Guard Stations not then connected, and to include the most important light stations that then had no means of rapid communications.
- 1933 Aug. 15 Lighthouse electrified with four 250-wt lamps.
Radio beacon installed.

- Sept. 15-16 Barden Inlet opened by hurricane.
- 1939 July 1 Light House Service incorporated into the U.S. Coast Guard.
- 1942 June Light extinguished for duration of war.
- 1949 Jan 26 120 foot radio tower added near lighthouse.
- 1950 Generators placed in ground-level room. Lighthouse fully automated.
- 1966 Mar. 10 Cape Lookout National Seashore was authorized by Public Law 89-366.
- 1972 Oct. 18 Listed on the National Register of Historic Places.
Weathervane still in place.
- ca. 1976 Fresnel lens removed, two DCB-24 aero-beacons installed with 15 seconds between flashes.
- ca. 1980 Metal storm doors installed at 1st and 2nd levels.
- 1982 Underwater electric cables run to the lighthouse from Harker's Island.
- 1988 Alternatives for stabilization of upper part of tower studied.
- 1989 July Stabilization project places metal shoring in tower and restructures watch-room gallery.
- 1992 Repainted during the summer. Pressure washing collapses well.
- 1994 Cape Lookout first-order Fresnel lens installed at Block Island Southeast Lighthouse, RI.
- 1995-96 Repainted at cost of \$46,000 by American Lighthouse Restoration Co.
Storm door and hatch at watch level replaced.
- 1996 Sept. 5 Hurricane Fran damaged windows.
- 1996-97 Major electrical upgrade in the tower to include main electrical wiring, junction boxes, emergency beacon, and lighthouse power controls.
- 1999 Windows replaced, metal entrance doors replaced, interior paint removed, selective painting; selective brick repair, and lightning protection accomplished.
- 2000 June Repainted.
- 2003 June 14 Lighthouse transferred from USCG to National Park Service.

- | | | |
|------|-------------|---|
| | Sept. | Hurricane Isabel destroyed coal shed. |
| 2004 | Oct. | Repainted by High Structure Maintenance LLC. |
| 2005 | May 12 | Engineering study of lighthouse by Stanford White Associates. |
| | Sept. 15-16 | Hurricane Ophelia. |
| 2006 | Feb. | Shoreline replenished on sound side to protect lighthouse. |
| | Aug. 31 | Tropical Storm Ernesto. |
| 2008 | Feb. 23 | Public tours of the lighthouse suspended for reasons of safety. |

BIBLIOGRAPHY

- Bachman, Karen. *The Insider's Guide to the Outer Banks 25th edition*. Guilford, CT: Globe Pequot Press, 2004.
Web site: <http://www.insiders.com/outerbanks/main-history3.htm#Heading6>. (28 July 2008)
- Barnes, Jay. *North Carolina's Hurricane History*. Chapel Hill, NC: UNC Press, 1995.
- Bisher, Catherine W. *Architect and Builders in North Carolina: A History of the Practice of Building*. Chapel Hill, NC: UNC Press, 1990.
- Cape Hatteras National Seashore web site, <http://www.nps.gov/caha> (24 July 2005).
- Crompton, Samuel Willard and Michael J. Rbein. *The Ultimate Book of Lighthouses*. San Diego, CA: Thunder Bay Press, 2003.
- DeBlieu, Jan. *Hatteras Journal*. Winston-Salem, NC: John F. Blair Publisher, 1998.
- Denson, C.B. *Memoir of Major General William Henry Chase Whiting*. Raleigh, NC: Edwards & Broughton Printers and Binders, 1895.
- Duffus, Kevin P. *The Lost Light, The Mystery of the Missing Cape Hatteras Fresnel Lens*. Raleigh, NC: Looking Glass Publications, 2003.
- Edwards, E. J. and H. H. Magdsick. "Light Projection: Its Application." In *Illuminating Engineering Practice, Lectures on Illuminating Engineering Delivered at the University of Pennsylvania, September 20-28, 1916*. New York: McGraw-Hill Book Co., 1917.
- Everhart, William C. *The National Park Service*. New York: Praeger Publishers, 1972.
- Hairr, John. *Images of America, North Carolina Lighthouses and Lifesaving Stations*. Charleston, SC: Arcadia Publishing, 2004.
- Holland, Francis Ross. *A Survey History of Cape Lookout National Seashore*. Washington: National Park Service, Cape Lookout National Seashore, 1968.
- _____. *America's Lighthouses: An Illustrated History*. New York: Dover Press, 1988.
- Instructions to Light-Keepers, 1902 edition*. Washington: Government Printing Office, 1902. Reprinted, Great Lakes Lighthouse Keepers Association, 1989.
- Jones, Tommy H. *Historic Structure Report, Cape Lookout Life Saving Station*. Cape Hatteras National Seashore, North Carolina. National Park Service, 2004.
- Jones, Ray. *The Lighthouse Encyclopedia: The Definitive Reference*. Guilford, CT: The Globe Pequot Press, 2004.
- Lighthouse Digest, http://www.lighthousedepot.com/lite_digest.asp (12 July 2008).
- List of Light Houses, Lighted Beacons and Floating Lights of the Atlantic, Gulf and Pacific Coasts of the United States. Prepared by the Secretaries under a Regulation of the Light House Board, corrected to January 1, 1869*. Washington: 1869.

Lighthouse Keepers of Cape Lookout Lighthouse 1845-1912, National Archives Microfilm Publication Micro Copy 1373 Roll 3.

Long, E. B. *The Civil War Day by Day: An Almanac 1861-1865*. Garden City, NY: Doubleday & Company, Inc., 1971.

Loonam, John. *Cape Lookout Lighthouse*. Bertie NC: Self Published, 2000.

<http://www.itpi.dpi.state.nc.us/caroclips/CapeLookoutstory.htm> (July 2008)

McNaughton, Marimar. *Outer Banks Architecture: An Anthology of Outposts, Lodges and Cottages*. Winston-Salem, NC: John F. Blair Publisher, 1998.

National Register of Historic Places Nomination: Cape Lookout Light House, NC. Raleigh, NC: North Carolina Division of Archives and History, Department of Cultural Resources, 1972.

Pilkey, Orrin H., and Neal, William J. eds. *The North Carolina Shore and Its Barrier Islands. Restless Ribbons of Sand*. Durham, NC: Duke University Press, 1998.

Powell, William S. *The North Carolina Gazetteer: A Dictionary of Tar Heel Places*. Chapel Hill, NC: UNC Press, 1968.

Putnam, George R. *Lighthouses and Lightships of the United States*. Boston: Houghton Mifflin Co. 1917.
Available at <http://www.books.google.com>.

Report of the Officers Constituting The Light-House Board convened under instructions from the Secretary of the Treasury to Inquire into the condition of the lighthouse establishment of the United States under the Act of March 3, 1851. Washington: A. Boyd Hamilton, 1852.

Roberts, Bruce, and Ray Jones. *Southern Lighthouses: Outer Banks to Cape Florida*, 3rd ed., Guilford, CT: Globe Pequot Press, 2002.

Stick, David. *The Outer Banks of North Carolina 1584-1958*. Chapel Hill: UNC Press, 1958.

_____. ed. *An Outer Banks Reader*. Chapel Hill, NC: UNC Press, 1998.

_____. *Graveyard of the Atlantic: Shipwrecks of the North Carolina Coast*. Chapel Hill, NC: UNC Press, 1952.

_____. *North Carolina Lighthouses*. Raleigh, NC: North Carolina Division of Archives and History, 1980.

Strobridge, Truman R. *Chronology of Aids to Navigation and the United States Lighthouse Service 1716-1939*
http://www.uscg.mil/history/articles/h_USLHChron.asp (May 2008)

U.S. Coast Guard web site <http://www.uscg.mil/history/> (May 2008).

United States Coast Pilot: Atlantic Coast. Part VII. From Chesapeake Bay Entrance to Key West. Washington: Government Printing Office, 1895. Available at <http://www.books.google.com>.

Zepke, Terrance, *Coastal North Carolina: Its Enchanting Islands Towns and Communities* Sarasota, FL: Pineapple Press, Inc., 2004

Material on file at archives of National Park Service, Cape Lookout National Seashore, Harker's Island, NC.

Manuscripts and Reports

Beckman, E.J. ed. *Report of the Light-House Board, 1869*, 2006.

Bodie Island Lighthouse Historic Structure Report

http://www.nps.gov/history/history/online_books/caha/caha_bodie_hsr.pdf

Cape Lookout Lighthouse Keeper's Dwelling (1907) Historic Structure Report

http://www.nps.gov/history/history/online_books/calocalld_hsr.pdf

Cape Lookout National Seashore, Discussion of Alternatives. 1998. National Parks Service Southeast support Office Planning Division. Atlanta, GA.

Cape Lookout Lighthouse Letter Book Index 1805-1900.

Erosion Study Cape Look Lighthouse Study. 1978. U.S. Army Corps of Engineers; Wilmington, N.C.

Notice to Mariners (No. 43.) Treasury Department September 19, 1859.

Request for Proposal to Construct Light House, Department of the Treasury, November 30, 1810. Transcribed by Karen Duggan.

Drawings (Arranged Chronologically)

"First Order Lantern, U.S.L.H Establishment, plate No.20" no date. [623/60955].

"Cape Lookout Light House, First Order, From Lieut. W.H.C. Whiting, 5th Dist" ca. May 1857. [623/60937]

"U.S. Light House Board, Cape Lookout Light House, Drawn under the direction of Lieut. Wm. H.C. Whiting, Corps Engr by Benj. Goodness" Same as above with additional annotation 1888 and checkering detail. [623/60937A].

"Cape Lookout L. House N.C., Temporary repairs wooden in Indian yellow, Drawn by G. Castor Smith Actg. Engr. 4th L. H. Dist., From measurements by Jere. P. Smith" dated 28 July 1864. [623/60936A]

"Cape Lookout Lt. Sta. N.C., Sectional outlines of Lantern & construction of Watch Room & Lantern Floors from Dimensions taken at the site by Mr. C. H. Vinson, March 28th 1912." [623/60928]

"Cape Lookout Light Station, N.C. Storm Door & Parapet Floor. Bureau of Lighthouses, Washington, D.C. Sept.10, 1913." [623/60915]

"Cape Lookout Light Station, N.C. New Air Lock & Repairs, Bureau of Lighthouses, Washington, DC, Sept 10, 1913." [623/60916]

"Reinforcing Rods in Parapet Floor, Cape Lookout Lt. Stn., Office of the Lighthouse Inspector Fifth District, Baltimore, MD," Jan. 16, 1914. [623/60918]

"Cape Lookout Light Station, N.C., Assembly of Motor, Bureau of Lighthouses, Washington, D.C., Sept 10, 1913." Listed as 1 of 7 sheets

2 of 7 – Motor Details

3 of 7 – Motor Details

4 of 7 – Motor Base, Chain Guides, etc

5 of 7 – Motor Case

6 of 7 – Occulting Apparatus Details

7 of 7 – Occulting Apparatus Details

[623/60924]

“Cape Lookout Light Station, N.C., Assembly of Occulting Mechanism. Bureau of Lighthouses, Washington, D.C., Dec. 1913.” [623/60932]

“Cape Lookout Lt. Sta. N.C., Alterations to Radio Installation, Civil Engineering, C.G. Drawing No. ND-953.” Jan. 26, 1949. [623/60909A].

“Cape Lookout Lt. Sta., Arrgt. Of Equipment in Base of Lighthouse, 5th District Civil Engineering, USCG Chief of Division, C.G. Drawing No. ND-1299, May 1950.” [623/60901].

“Lighthouse Stabilization, Cape Lookout Lighthouse, Cape Lookout, North Carolina. U.S. Coast Guard Shore Maintenance Detachment, Cleveland, Ohio. 1988.” 7 Sheets: 1. Lighthouse Details; 2. Section and Rail Details; 3. Frame Section; 4. Frame Details; 5. Frame Details; 6. Latern [sic] Frame Details; 7. Reference Drawing.

“Lighthouse Stabilization, Cape Lookout Lighthouse, Cape Lookout, North Carolina. U.S. Coast Guard Shore Maintenance Detachment, Cleveland, Ohio. 1988. Owen Miscellaneous Metals Inc, Cayce S.C., 1989.” Similar to above, arranged as sheets E-1-5 corresponding to sheets 3, 2, 6, 4, 5. Annotated and supplemented.

Maps and Surveys

Deed and Property Survey February 17th, 1830, Samuel Leffers. Original found in National Archives College Park, MD. Carteret County Deed Book V, 103.

“Cape Lookout, Light Station, N.C., Building Surveyed 1893 by H. Bamber” [623/60935].

“Cape Lookout, Light Station, N.C., Reservation Surveyed 1893 by H. Bamber” [623/60927].

“Plat of Cape Lookout Light Sta., Dimensions received from Mr. John Lewis, Supt. Of Const, April 20th 1889” with annotation for 1907 improvements [623/60906].

“Plat of Cape Lookout Light Station N.C. Showing proposed location of new Keeper’s Dwelling &c. Dimensions received from Mr. John W. Lewis Supt. Of Construction, July 31, 1906.” [623/60906B]

“Cape Lookout Light Station N.C. Plat Copied Febr’y 18th .1910 brought up to date March 20, 1959; subdivided April 28, 1959.” [623/60906H].

“U.S. Coast Guard Property, Cape Lookout, Carteret County, N.C. by J.G. Hassell, October 1961.” [623/60980]

“Cape Lookout L.B.S. Relocation of Station Preliminary, U.S. Coast Guard Fifth District, Portsmouth VA. Civil Engineering, July 27, 1962” [623/60942]

C. PHYSICAL DESCRIPTION

General Description:

The Cape Lookout Lighthouse is located on the uninhabited barrier island known as South Core Banks. The island is some three miles south of the North Carolina mainland and some ten miles southeast of the colonial port city of Beaufort. The lighthouse is the second built in this location.



Figure C-1 Satellite view of Cape Lookout and the North Carolina coast. Compare with Figure B-1, the 1856 map of Cape Lookout Shoals.

The lighthouse sits on a gentle rise on a narrow sliver of open land, its height reaching about 165 feet to the top of the lantern dome's finial. A four-foot wide, nineteenth-century brick walkway leads 165 feet north-northwest from the lighthouse to the Keeper's Quarters, a two-story weatherboarded wood frame house. It now contains park interpretive exhibits on the first floor and private living

quarters for volunteers and other occasional occupants on the second floor.

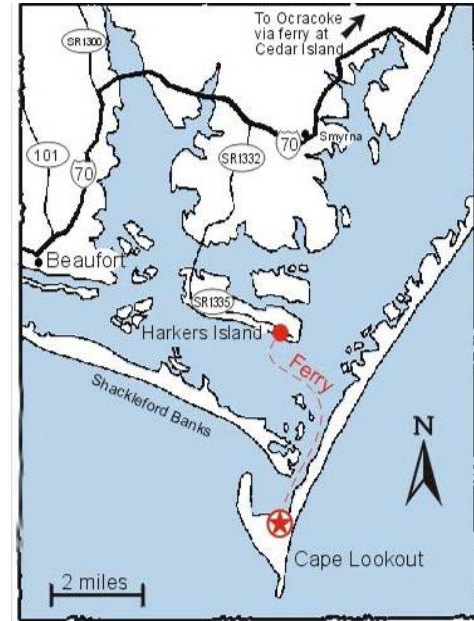

Figure C-2 Location of Lighthouse and Ferry

Close by, west of the Quarters, is the one-story, wood frame and weatherboard Radio Shack and attached Battery House.

Northeast of this group, down a wooden boardwalk in a grove of low trees, is the one-story Light Station Visitor Center. This modern complex is open seasonally and contains gift shop, restrooms and a rest area.

The island is accessed only by boat. NPS personnel, support staff and volunteers leave by agency craft from the boat slip at the Cape Lookout National Seashore Visitor Center on the east end of Harkers Island. They navigate through the many reefs of the shallow waters of Back Sound, pass near Shackelford Banks, and dock at the Park Service pier adjoining the Light Station Visitor Center.

Visitors come by small, shallow-draft, private ferries, also based on Harkers Island, or by personal craft. They, too, typically come ashore on the more protected west side of South Core Banks, but anchor at the beach adjacent to the Keepers' Quarters.



Figure C-3 Shackleford Banks.

On most days, the tall slender lighthouse can be seen from Harkers Island, and it remains in clear view during the entire 15-minute boat ride to the shores of its island.



Figure C-4 Anchorage of private boats off the beach next to Keeper's Quarters.

The lighthouse was constructed in 1859 according to a standardized architectural design of the period. Though it was the first of this prototype built in North Carolina, several lighthouses of this design were built

elsewhere along the East Coast. The tapering tower is made primarily of brick topped by a sixteen-sided metal and glass lantern. Inside the lantern is the continuously rotating double beacon.



Figure C-5 The view looking northeast from Lantern Gallery: mooring beach, NPS pier and Light Station Visitor Center.

The tower exterior retains its distinctive black-and-white painted diamond pattern first applied in 1873. The lantern is painted black.

Blocks of granite are used for the sills and lintels of the tower fenestration. The south-side entry doorway, two short stone steps above grade, provides access to the first floor equipment room. The north-side entry doorway, accessed by twentieth-century wood stairs, provides access to the Second Floor and the base of five levels of cast-iron, spiral stairs. Each section between landings spans twenty-four feet of vertical rise. At the Seventh Floor or Service Level, the spiral stairs end and a short run of original cast-iron ladder stairs connects to the Eighth Floor Watch Level, the last landing within the brick tower. Ten small window openings, each with a pair of six-over-six wood sashes, provide

daylight along the climb from the Second Floor through Seventh Floor.

At the windowless Eighth Floor Watch Room, a small original doorway leads out to the Watch Room's Observation Deck that encircles the tower. From the Watch Room, another short run of original but narrower and steeper cast-iron ladder stairs connects to the interior landing of the Ninth Floor or Lantern Level.



Figure C-6 The view looking South.

The domed Lantern has sixteen sides of glass panels held in slender metal frames. Within one section is an original metal-and-glass door leading to the original narrow cast-iron Lantern Gallery that encircles the Lantern.

The interior metal surfaces of the Lantern are painted white, reportedly to enhance reflectivity of the beacon light. The two 1976 aero-beacons are mounted at the center of the

landing floor and dominate the Lantern interior space.

Construction Characteristics

Structural Systems

The structural system of the lighthouse tower is load-bearing masonry consisting of brick with granite sills and lintels at the fenestration.

The structural system of the lantern is metal framing with glass inserts between framing members to create a continuous, sixteen-sided, translucent wall. Curved metal framing supports the dome and its cladding of thin metal sheet roofing.

- *Foundations:* According to the drawings for the lighthouse prototype, the brick tower rests on a masonry platform at grade. The platform is not visible, but according to the drawings it is the width of the tower and rests, in turn, on a wider base of layered "concrete or stone" in decreasing diameter for an unspecified depth. Centered directly beneath the tower is a pylon of layers of stone. None of the actual below-grade characteristics have been verified.

- *Exterior Wall, Cross Walls & Core Wall:* Again according to the prototype drawings, the tower is double-walled, constructed of brick. Both walls are laid in a 5-to-1 common bond. At grade, the tower has a diameter of 28'-0". It is circled by a 2'-11" -wide brick walkway. The exterior face of the lighthouse tapers upward at a decline of 9/16" per foot. At the Sixth Floor landing, according to the prototype plan, the two brick walls merge to become one wall 2'-6" thick. The taper continues, and by the Eighth Floor Watch Room, the merged exterior masonry wall measures 1'-6" in thickness and the tower diameter is 12'-0".

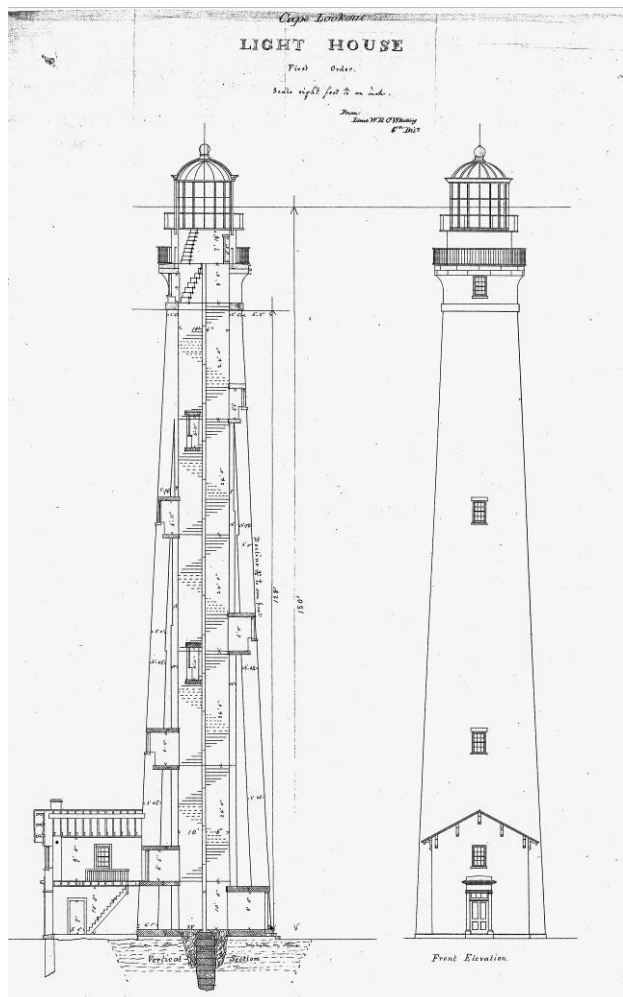

Figure C-7 1857 Whiting's 1857 illustration showing tapered walls

The central interior shaft containing the stair does not taper, but has a diameter of 10'-6" and retains that diameter as it extends from the floor of the First Floor to the top of the tower, the base of the Ninth Floor Lantern. This interior core wall, according to the drawings, is 1'-6" thick for the entire vertical height, while the outer wall, which is 4'-1" thick at grade, tapers at its 9/16" –per-foot ratio. The outer wall eventually joins the core wall to become the single 2'-6" thick wall at the Sixth Floor landing, continuing its taper to the top of the Eighth Floor, the top of the brick tower. Between the outer and core walls is a void

with a taper corresponding to the taper of the exterior wall.

Six equally spaced, radiating cross walls, each 9" thick, connect the outer and core walls along the way to the union of outer and core walls at the Sixth Floor.



Figure C-8 Modern masonry repairs in Watch Room.

The great majority of the bricks in the tower core are original and handmade. (At the intersection of the spiral stair treads with the core wall, there are some modern bricks, replacements installed when tread conditions were investigated in 1999. There are also sections of modern replacement bricks installed as part of the crack repairs to the interior of the Watch Room walls, perhaps performed at the time the steel reinforcement was installed in 1989.)

The bricks of the exterior wall also appear to be original and possessing the same visual characteristics as the core wall bricks, but more than a very limited inspection was hampered by the current exterior coatings. At

the outside surface of both the inside core wall and the exterior wall, the bricks have the same range of sizes. These are:

- Height: 2" to 2¼"
- Depth: 3¼" to 3½"
- Length: 7¾" to 8"



Figure C-9 Brickwork of interior face of core wall.

The visual characteristics of the bricks can best be seen on the interior of the lighthouse where paint and other finish coatings have been removed. These bricks can be classified as follows in decreasing order of color dominance: brown-rose, orange-rose, rose-brown. Speckling is common in all color ranges.

The mortar joints of both the outside and inside walls have a width of about ½" and are struck flush. However, on the core wall interior face, it is clearly evident that portions of the brickwork have been re-pointed with a hard, Portland cement-rich mortar. The re-pointing mortar is also fairly impermeable as evidenced by the re-pointed joints sitting proud, hard and rigid, while the adjoining bricks have spalled well back from the face of

the mortar. Similar spalling has not occurred on bricks adjoining the earlier mortar.

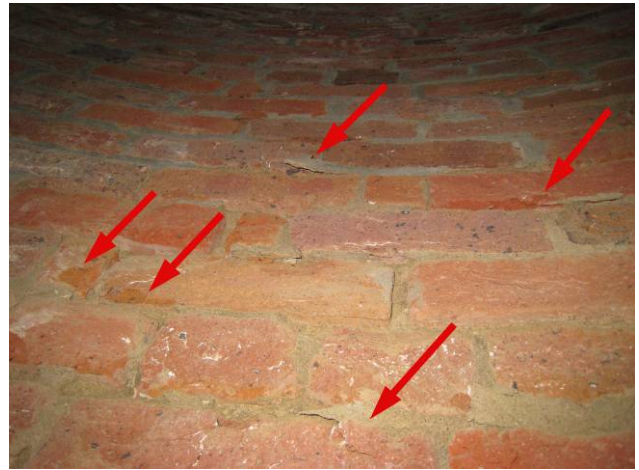

Figure C-10 Spalling brick adjoining Portland cement-rich repointing mortar.

On the exterior wall surface, the thick paint layers to a large degree mask both bricks and mortar. While the presence of Portland cement-rich repointing mortars could not be verified on the exterior, it is clear that portions of the brickwork are in need of repointing as revealed by the pattern of eroded joints seen in the irregularities of the coating.

The mortar analyses performed for this report indicate that both the original bedding and pointing mortars were composed of natural cement with no lime addition.

Further, the mortars have held up very well. These will be important considerations for future maintenance repair efforts. It is of historical interest that the cement was identified as American and not a European product. Although the exact provenance of the cement could not be established, it is chemically consistent with cements produced in northwestern Georgia. Further, the sand used for the mortar was identified as a very

clean and narrowly graded siliceous aggregate typical of fine beach sand. The material testers conclude that it is highly possible that the sand was harvested from the Outer Banks region, although the extracted sand is darker in color than a sample of sand removed from the island during the investigation. (See *Appendix D: Materials Analysis* for further discussion.)



Figure C-11 Natural cement bedding mortar exposed at Watch Room air vent.

The testing of bricks was necessarily limited to samples from the core wall interior wythe. The tests for compressive strength and water absorption indicate the bricks are adequate in terms of meeting the basic requirements of MW (moderate weathering) grade brick and are suitable for their intended use at the lighthouse. Areas of distress appear to be associated with the later use of the Portland cement-rich repointing mortars.

In addition, the condition of the bricks of the exterior wall is not known. These bricks have been water-blasted and subsequently covered with the current, thick, non-breathable coating. These actions are likely to have damaged the brick by removing portions of the fireskin and also trapping moisture,

conditions that may affect their overall water absorption and possibly their compressive strength properties. Additional testing of the exterior brick is recommended to confirm actual performance characteristics. (See *Appendix D: Materials Analysis* for further discussion.)



Figure C-12 A 1976-1981-era photograph of exterior masonry at Observaton Deck.

- **Column:** A hollow, round column, made of $\frac{3}{4}$ "-thick iron plate, is bolted together in sections and extends from the masonry floor of the First Floor to the Ninth Floor Lantern platform for the beacon. At all levels the column appears to be sound.

At the First Floor, the fluted iron column, 1'-4" in diameter, rests on a sandstone platform measuring 2'-2" x 2'-2" and sitting proud 3" above the top of the brick flooring. The column transitions to a 10" diameter which it retains through all the upper levels, although it changes at the Seventh Floor from fluted to smooth surface, and terminates at the Ninth Floor beacon platform.



Figure C-13 Center column on sandstone pedestal, abandoned emergency generator and fuel tank nearby.

The distance between the top of the First Floor to the top of the Second Floor landing is 10'-6". The distance between the top of the Second Floor landing to the top of the Third Floor landing is 24'-0", a distance maintained between each successive landing up to the Seventh Floor. Between the Seventh Floor and Eighth Floor, the distance is 8'-0" and between the Eighth Floor and Ninth Floor it is 7'-2"

- **Flooring Systems:** At the First Floor, bricks are laid in running bond in a mortar bed, presumably immediately on top of the masonry platform as indicated in the lighthouse prototype drawings.



Figure C-14 Bolted connection between column sections.

At the Second Floor, the lowest floor level of the spiral staircase, there is a pair of original iron I-beams that straddle the center column and support six wedge-shaped, interlocking, cast-iron floor sections. Each of the six floor sections is mortared into the perimeter brick wall and also connects to the center column, thus providing a complete horizontal covering of the center core space.

Each subsequent landing, except for the Third and Eighth Floor, consists of three wedge-shaped iron floor sections providing a half enclosure and a single iron I-beam.

At the Third Floor, a level damaged by the Confederate explosion, the landing was rebuilt in the 1867 repair effort and is comprised of wood plank flooring (3/4" x 5") atop two wooden joists (2 7/8" x 8") in addition to the original I-beam.

At the Eighth Floor Watch Level there are two original I-beams and six original wedge-shaped cast-iron floor plates creating a full horizontal enclosure as at the Second Floor.



Figure C-15 Wood deck and floor joists of rebuilt 1867 Third Floor landing.

Significantly, only the six plates of the Second Floor landing have nibs at the underside of the adjacent sides of the floor panels. These nibs are for bolts to connect adjacent panels. The occurrence of nibs at only the Second Floor landing plates is further confirmation that these are replacement plates, dating to the 1867 repair.

It is also noteworthy that one of the current six metal floor plates of this Second Floor landing is different from the others. It does not have nibs for bolts, appears to have less wear, may be made of steel instead of iron, and is painted a different color (green instead of black.) The floor plate which this plate replaced is stored nearby. The reason for the installation of this one odd floor plate is not clear. Perhaps the 1867 plate was removed for a while to allow a physical connection between the First and Second Floors, was temporarily misplaced, and therefore replaced when a complete enclosure was again desired.

Although there is some surface corrosion as well as surface abrasion on sections of the cast-iron flooring panels and I-beams, these conditions are largely a matter of aesthetics.

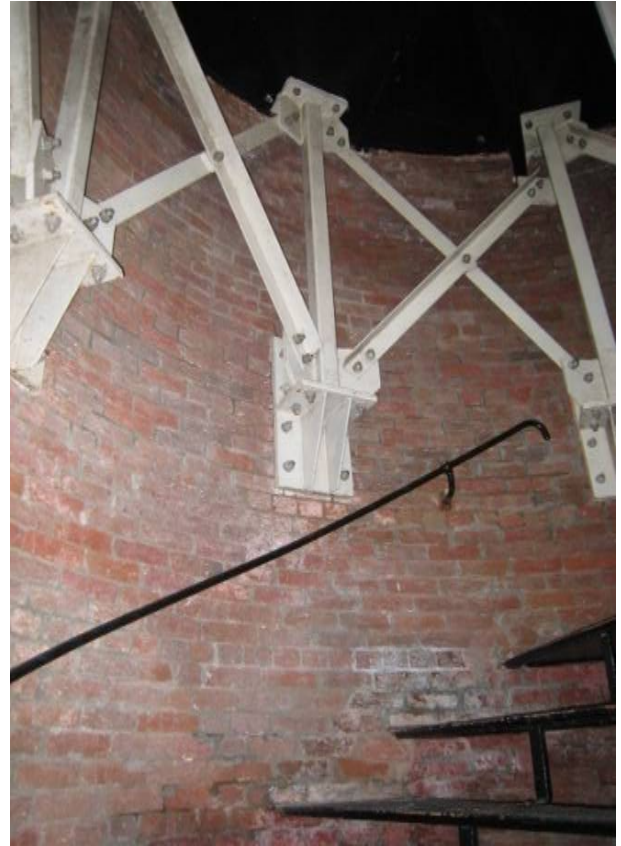

Figure C-16 1989 steel framing at Seventh Floor.

- *Roof Framing:* The sheet metal dome is supported with cast-iron ribs and interconnecting 7/8" diameter iron rods, and rests on a cast-iron wall plate. Seventeen vertical iron-framing members hold glass panels to create a sixteen-sided wall enclosure (Lantern) and to support the wall plate. This iron framing sits on an iron floor plate atop the masonry tower. The cross bracing is copper-based, probably brass. Corrosion is extensive among the supporting iron elements.



Figure C-17 Structural supports and central ventilator of dome.



Figure C-18 1989 steel reinforcement of Gallery deck and connecting rod.

Outside, steel angles were added to the underside of the Lantern Gallery. Stainless steel, 1" diameter rods were added as connectors between the Lantern Gallery and Observation Deck. (See *Appendix B: Structural Assessment & Carrying Capacity Analysis.*)

Utility Systems

- *Mechanical Systems:* There is no natural gas service to the island. (However, the Keeper's Quarters has propane gas for the cooking stove and refrigeration. A propane storage tank is nearby.)

- *Electrical Systems:* The Carteret-Craven Electric Cooperative provides single phase, 110/220v electrical service directly to the Lighthouse via underwater cable from Harkers Island. The cable was installed in 1982. (Excess power is then available to the Keeper's Quarters. The Light Station Visitor Center has electricity supplied by a generator which is shut down at the end of each day.)

The electrical service in the Lighthouse was upgraded in 1996-97. Upgraded items include new wiring, junction boxes, emergency beacon and power control. Electrical wiring is typically contained in conduit. Along the spiral staircase, a utility shop type fluorescent lighting fixture (having a length of 4'-0" with two bulbs and no lens) is mounted on the surface of the underside of each landing. A grounded electrical outlet is also provided at the landing.

A 1970s vintage emergency generator is located at the First Floor of the Lighthouse. However, it is disconnected and non-operational.



Figure C-19 Typical shop-type utility lighting at spiral stairs floor landing.

- **Plumbing Systems:** A deep water well of some 300 feet provides potable water for the Visitor Center and Keeper's Quarters, but not the Lighthouse. (A shallow well, used as a reservoir during the water blasting of the Lighthouse in 1991, was fouled by the operation and subsequently had to be abandoned.)

The Visitor Center and the Keeper's Quarters have separate septic fields. The Lighthouse has no provision for waste disposal.

Exterior Features

- **Roof, Ventilator and Rainwater Collection /Dispersal:** The dome is sheathed with sections of copper roofing panels, perhaps the original. A formed cornice is configured to serve as a roof gutter and small scupper/downspouts direct the runoff out away from the Lighthouse.

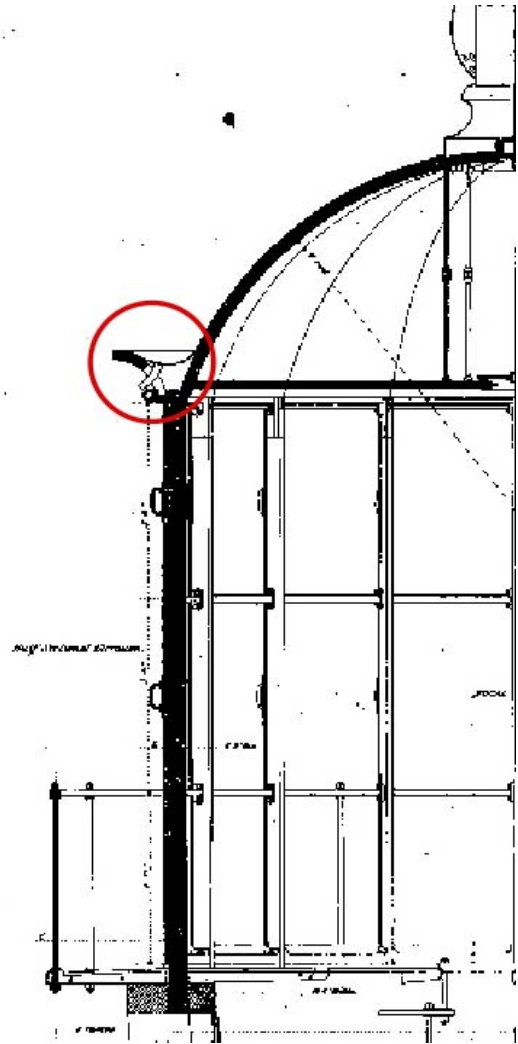

Figure C-20 Detail of historic construction drawing showing roof gutter and scupper/ downspout.

Atop the dome is a sheet metal finial pierced and screened to provide natural ventilation. Presumably, this element also is made of copper.

- **Lantern & Lantern Gallery:** The sixteen vertical sections of glass that form the sides of the Lantern are held in place by vertical cast-iron framing members and horizontal cross-bracing of a copper-based material, perhaps brass. An iron sill plate attaches the Lantern atop the masonry tower. There are extensive amounts of corrosion at the iron elements.



Figure C-21 Lantern, Lantern Gallery and Watch Level Observation Deck.

Four presumably original iron rods, each 7/8" in diameter, connect the sill plate of the Lantern to the floor at Watch Level. These rods have extensive corrosion with at least one severely compromised.



Figure C-22 Corroded connecting rod at Watch Room floor plate.

Along the outside perimeter of the Lantern is the narrow Lantern Balcony. This Balcony has sixteen cast-iron floor plates, probably the original. These plates are in very poor condition with extensive corrosion, numerous breaks and some loss of material. Stainless steel angles were added in 1989 for support beneath the floor plates. During those same repairs, the current stainless steel railing system was installed. This railing consists of 1½" round stanchions with a flat 1" x 2" handrail 38" above floor level.



Figure C-23 Broken floor plates of Lantern Gallery.

- *Watch Level Observation Deck:* In 1913, probably in an effort to isolate and protect the incandescent oil vapor lamp and the new occulting mechanism, plans were prepared for constructing air locks at the Watch Room Gallery and Service Room. Accordingly, the current deck system of steel pans filled with cement topping was installed the following year to increase the Gallery width to 4'-2" in order to accommodate the new air lock. A pipe railing was installed along the perimeter of the new deck (Figure B-12).



Figure C-24 Section of 1914 Observation Deck railing at North Carolina Maritime Museum.

At unknown date(s), the original 1914 railing and air lock were removed. The imprint of the air lock is still visible in the deck's cement. Remnants of the stanchion anchors remain in place (Figure C-25). A salvaged section of the 1914 railing is in the North Carolina Maritime Museum (Figure C-24). The current railing is a replica of the original 1914 railing. It stands 45" tall and is constructed of two 2" round rails and 2½" round stanchions, all of steel.

The pan deck system appears to be in good condition. The railing is extensively corroded and in need of replacement.

- **Walls:** The brick walls are discussed above in the section *Structural Systems – Exterior Wall, Cross Walls and Core Wall*.

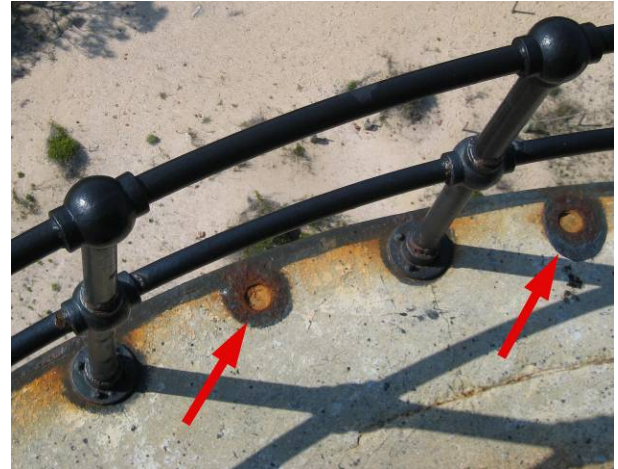

Figure C-25 Remnants of 1914 stanchion anchors and replacement railings of unknown date.

- **Air Vents:** Four round 8"-diameter vents constructed of sheet copper are equally spaced in the perimeter wall at the Watch Level. Apparently original, each vent is Z-shaped with the exterior opening approximately 12" below the interior opening where a manually-operated, five-point, cast-brass closer adjusts airflow.



Figure C-26 Exterior view of one of four Watch Room air vents.

• *Doorways:* There are four exterior doorways. Three are in the tower and one is in the Lantern. The presumably original brass-and-glass door of the Lantern remains in place, though it needs cleaning and adjustment to operate smoothly. The three original brick-and-granite door openings of the tower are intact, though the original doors and framing have been modified.

At both the First Floor and Second Floor, the original doorway framing and door were replaced c. 1980 with steel frame and steel, flush-panel door. (These doors were severely rusted when they were replaced in 1999 with the current doors of same design.) In both locations, the original door was probably board-and-batten with wrought-iron strap hinges and pintels. Such a door is visible at the Second Floor in an unlabelled, c. 1945 photograph in the park's collection.



Figure C-27 Circa 1945 photograph of doorway, (CALO Coll.)

The First Floor replacement door unit has its c.1980, 2" x 2" square steel frame and c. 1999 flush-panel steel door. This door measures 2'-7" x 6'-6" x 1¾" and has at the bottom a metal vent measuring 1'-7" wide x 1'-5" tall. The door hardware is still in place which includes

two, "Arrow" brand, aluminum ball door knobs, a closer and a 5"-wide brass threshold.



Figure C-28 Original masonry opening for First Floor doorway with modern infill and steel door.

At the Second Floor, the steel door frame and door are of the same installation periods as those of the First Floor and physically match as well except that this door measures 2'-6" x 6'-6" x 1¾". Both this and the First Floor door suffer from extensive corrosion, are in poor condition but remain operational.



Figure C-29 Modern entrance stair to Second Floor

A third exterior doorway is at the Eighth Floor, connecting Watch Room with Observation Deck. The original masonry opening is intact with brick jambs and granite lintel. It measures just 2'-3½" wide by 4'-9" tall. In 1914, the Observation Deck was widened and an air lock measuring 3'-4" x 5'-6" was constructed. When this air lock was removed is unknown, but the wall imprints are still visible in the cement deck.

The appearance of the 1859 door that was set in this opening is also unknown but probably was a board-and-batten design similar to the one at Second-Floor level. How this doorway was modified in the 1914 remodeling, if at all, is uncertain. The 1913 plan for the air lock construction shows a doorframe and door but does not identify either repair or modification. No records have been located that address subsequent action affecting this doorway.

The current door, a ship's hatch with six latching dogs, measures 1'-6" in width by 3'-0" in height and is made of painted cast aluminum. According to park personnel, it was installed in 1996. Whether this door replaced a steel ship's hatch of same design is unknown.

The exterior door plate is steel and has extensive wear and corrosion suggesting that it may date to a much earlier period with a steel door of similar design to the current aluminum one.

The brick jambs of this masonry opening are reinforced flush, stainless-steel panels. The time of installation is not known but the lack of wear suggests a recent date perhaps 1996 the date of door replacement. The bottom of this masonry opening is accessed from the

interior by a 10" tall, painted masonry step, and the base of the hatch door opening is another 9" above the masonry.

The original masonry opening is sound and the hatch door is in good condition and operational.



Figure C-30 Ship's Hatch at Observation Deck.

A fourth doorway is at the Lantern. Apparently an original feature, it is made of brass framing with two, glass panels, designed to conform to the framing configuration of the Lantern. This door permits passage between the Lantern and the Lantern Gallery. The door metal is heavily encrusted with paint and difficult to operate.

- *Windows:* Apart from the glass expanses of the Lantern, there are ten windows in the Tower. All ten of the current window units are replacements, fabricated and installed in 1999 by the NPS Historic Preservation Training Center of Shepardstown, West Virginia. Each window is an operable, double-hung, sash design made of wood.



Figure C-31 Doorway to Lantern Gallery.

The design characteristics mimic the replaced sash but are not a duplicate, as confirmed by comparison with the salvaged sash in the collection of the North Carolina Maritime Museum. (See *Appendix A: Documentation Drawings*.) In addition to the sash, the replacement material includes the sill and interior and exterior casing. The framing could not be observed to determine if had been replaced as well.

Two earlier are known to survive. One is in the collection of the North Carolina Maritime Museum in Beaufort. Museum records indicate the sash was accessioned in 1992. Its exterior is weathered, suggesting a long period of service, but it is intact and in good condition. Although its date of construction is not known, its muntin profile is consistent with other windows of the mid-nineteenth through early-twentieth century.



Figure C-32 Typical replacement window unit.

- *Apron:* Encircling the base of the Lighthouse at grade is a brick walkway of unknown age. The bricks are handmade and laid as four, staggered, soldier courses end to end for a sidewalk width of 2'-10½".



Figure C-33 Brick Apron at intersection with brick walk to Keeper's Quarters. Note post and stone base for previous stairs.

• *Entrance Stairs:* According to park personnel, the current L-shaped configuration of stairs and landings was installed in the 1980s. The wood members are treated pine, unpainted, and cut to modern dimensions. They were constructed adjacent to and connected with remnants of a previous stairs.



Figure C-34 Two earlier but twentieth-century and severely deteriorated wood posts and one cross beam



Figure C-35 Stairs for Main Entrance.

The earlier elements include two 6" x 6" posts and their 2½" x 9¼" cross beam, all of which are attached to two modern 5 3/8" x 5 3/8" posts that support the entrance landing. These two early posts have extensive rot. The 1980s elements remain in good condition though the entrance landing posts would benefit from additional support as the earlier, now supplemental, posts continue to deteriorate.



Figure C-36 Modern lightning rod at Gallery railing.

• *Lightning Protection:* The prototype drawings indicate a lightning rod atop the roof finial. Today, a group of modern lightning rods include one atop the dome and four at the Lantern Balcony rail. Two grounding cables connect to this rail, one at the north side and one at the south, and then run down the face of the masonry to grade. The south ground cable is disconnected at the Eighth Floor.

• *Finishes:* According to the testing of exterior finishes prepared for this report, the brick masonry contains two campaigns of a red

limewash followed by six campaigns of black and white paint (in a harlequin pattern.) This finding apparently confirms the application of a coating as opposed to the simple exposure of the brickwork to give the red appearance noted in the 1859 *Notice to Mariners*.



Figure C-37 Physical evidence of red limewash on tower's exterior masonry.

The later black and white paints apparently post date the 1873 decision of the federal Light House Board to implement the current distinctive diamond pattern. The recent paints applied to the masonry are synthetic based, very rubbery and non-breathable. Probably applied for their waterproofing capability and durability, they belong to a category of paint that has proven to be harmful to soft, handmade bricks, especially in combination with the use of hard, non-permeable repointing mortars as are found at this lighthouse.



Figure C-38 Tower finishes c. 1976-1981.

Unfortunately, the metalwork of the lantern contains only recent layers of paint (approximately 2-5), all of which are black, and no evidence of historic finishes. However, the 1859 *Notice to Mariners* also identifies the color of the lantern as being black. This documentary source, therefore, remains the best indication of the original lantern color.



Figure C-39 Exterior exposure of lighthouse window sash in the collection of the North Carolina Maritime Museum.

The window sash salvaged from the lighthouse and now part of the collection of the North Carolina Maritime Museum, a sash believed to be early if not original, has

between 15 and 20 layers of paint as would be expected of an element with some age. The earliest layers are white with the later layers showing evidence of the intersection of the black and white diamond pattern.

Unfortunately, the combined physical evidence of sash design and finishes does not confirm that this sash is indeed original or even that it remained in its original window opening. It was not unusual for sash to be moved from window to window during repairs and other operations. It would not be surprising, too, if the diamond pattern shifted slightly at some point. What can be said is that this sash has some age and in its later years was in a window located at the intersection of the diamond pattern. (See *Appendix D: Materials Analysis.*)

Interior Features - Typical Characteristics:

- ***Room Dimension:*** At each level of the lighthouse, the space is circular and measures 10'-6" in diameter.

- ***Brickwork:*** The interior core wall of the Tower is constructed of handmade brick laid in a 1-to-5 common bond. (See *Exterior Features – Walls* for a more detailed description.) In 1999, the brickwork was water blasted. The bricks' outer protective surfaces that face the Tower's interior were severely eroded in the process, exposing the soft interior of the bricks. Some portions of the brickwork were then spot-pointed with a much too hard, impervious mortar. The combination of damaged brick and impervious mortar is causing the damaged bricks to suffer further damage from moisture migration and spalling.

- ***Lintels and Sills:*** Throughout the Tower, gray granite is used for the door and window lintels and doorway sills.



Figure C-40 Granite doors sill at Second Floor entrance. Note modern infill, door frame, and door.



Figure C-41 Typical Spiral Staircase section as found from Second Floor to Seventh Floor.

- ***Spiral Staircase:*** The spiral stairway extends from the Second Floor to the Seventh Floor. Each tread is wedge-shaped and made of cast iron 1" thick. At the narrow end where it connects to the column, the tread is 4" wide. At the flared end where the tread intersects the masonry (then extends 4" into the wall) the tread measures 1'-6" wide. The distance from outer edge of column to the face of the

masonry wall is 4'-10". From top of tread to top of adjacent tread is 8".

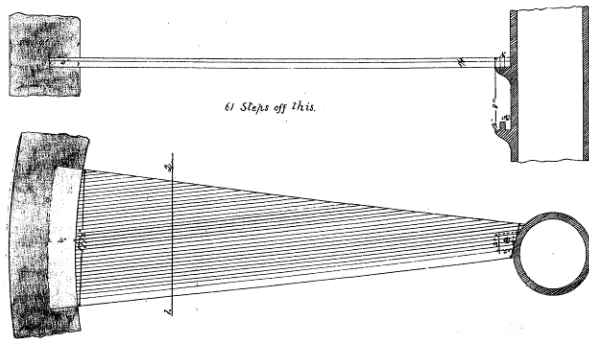

Figure C-42 Original drawing of Spiral Stair tread.

According to Union documents, 61 replacement steps were to be ordered; the exact number that was ordered, arrived or installed has not been confirmed. Three very clean steps without evidence of wear were discovered in Second Floor storage. Perhaps they were left over from the initial installation, or found to be unnecessary during the repairs. No documentary reference has been found. Inspection of the five runs of these cast-iron steps did not find a distinction among them; all steps appear to be identical, presumably from the same foundry, though no foundry markings were found. Inspection of the masonry walls for evidence of the 1867 installation of replacement treads was hampered by the disruption of the masonry caused by the 1999 inspection of treads which removed masonry at the treads. There are photographs of the 1999 inspection in the park's archives.

- *Staircase Landings:* From the Second Floor through the Eighth Floor, with three notable exceptions, the landings are made up of identical wedge-shaped, 1"-thick cast-iron floor plates.

One exception is a single plate among the six at the Second Floor which is clearly a modern replacement. Its design is unlike any other floor plate and it is painted a different color as well. It is not known when or why this plate was installed. The original floor plate is stored nearby. The reason the original plate was removed is not clear; perhaps it was removed to accommodate the operation of added equipment. Why the early floor plate was not reused when the decision was made to close up the floor again is also not clear; perhaps the early floor could not be located.



Figure C-43 Photograph from 1999 inspection. (CALO Coll.)

The second exception is the six matching floor plates of the Second Floor landing, including the five currently in place and the one extra noted above. These six are very similar in appearance to the metal floor plates of other landings, but with one distinctive difference; they have nibs on the underside for connection with bolts between adjoining plates. These nibs are not present in the apparently original, 1859 floor plates of other landings. These six plates apparently date to the 1867 post-Civil War repairs.



Figure C-44 Modern replacement floor plate at Second Floor landing.

The third exception is also a mystery. Unlike all the landings above grade, the deck of the Third Floor landing is made of wood, not cast-iron. In the 1864 Union drawing of the temporary repairs, both the Second Floor and Third Floor original landing are absent, victims of the Confederate explosion. The makeshift runs of temporary wood stairs bypass the original locations of these two landings. In addition, the Union assessment calls for nine replacement floor plates, a number appropriate for the six needed at the full landing at the Second Floor and three for the intermediate half-landing of the Third Floor.

The Second Floor landing apparently was rebuilt with replacement iron floor plates, but the Third Floor landing is instead made of wood. The original cast-iron beam apparently was reused, but there are two added wood joists to help support a wood board deck. No documentary explanation for this change in planning has been identified.

Because there are no records of what was actually ordered, what arrived, or what was installed, a number of scenarios are plausible. Perhaps only six floor plates were mistakenly ordered or delivered, necessitating the construction of the Third Floor landing with available materials.

For whatever the reason, the Third Floor landing is different. Its construction seems certainly to date to the 1867 repair effort. And as tangible evidence of an important chapter in the lighthouse's history, it is exceedingly valuable.

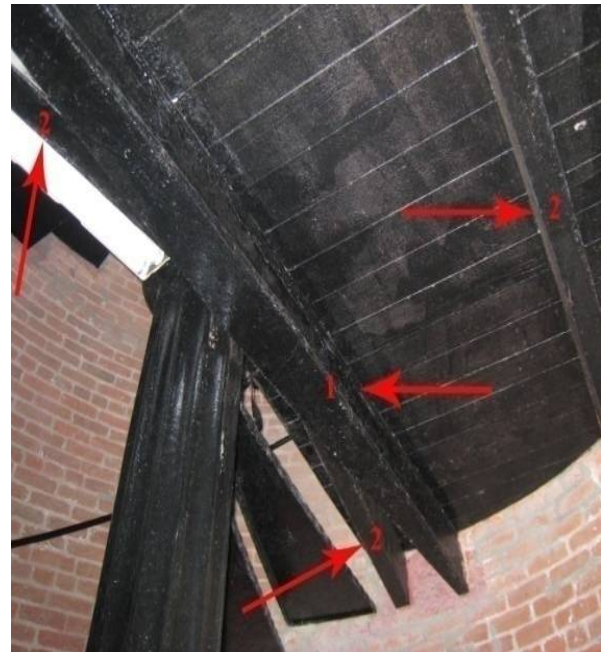

Figure C-45 Third Floor Landing with reused 1859 cast-iron I-beam (1) and 1867 wood framing (2).

- *Handrail:* Along the outer masonry wall for the run of the spiral staircase, there is a painted, round, iron handrail, 1" in diameter, apparently the original. The handrail is in good condition except for the masonry anchors, several of which are corroded and one has rusted through.



Figure C-46 Original iron handrail of 1-inch diameter.

- **Windows:** In the tower, all ten window units, including sash and exterior and interior casing, were replaced in 1999. All are in good condition. (See *Exterior Features – Windows* for further discussion.)

- **Finishes:** Because of recent restoration efforts, many of the historic interior finishes have been removed. While some areas of preserved finishes were located during the process of the testing for this report, the majority of the finishes have been disturbed. Some of the best evidence of interior finishes was found on the salvaged wood components currently in storage at the North Carolina Maritime Museum.

The interior brick surfaces contain minimal evidence of finishes, having been thoroughly blasted in the 1990s. The walls not easily cleaned, such as the narrow passages of the entry vestibules and window wells, generally

contain the best evidence. In these locations, the surfaces retain evidence of limewashes. Their presence is consistent with historical accounts of another lighthouse of the region, specifically Bodie Island to the north where interior surfaces were whitewashed on a regular basis. This practice was consistent with nineteenth-century standards for maintenance and hygiene. Unfortunately, the general lack of physical evidence prevents further documentation.



Figure C-47 Spiral stair and masonry finishes, 1976-1981 photograph. (CALO Coll.)

The interior woodwork has a fuller finishes history. The Third Floor wood landing was painted a khaki color followed by red-browns and then layers of black, the current color. The fragment of the 1914-era, Seventh Floor (Service or Storage Level), air-lock board wall, door and frame in the Maritime Museum collection contain this khaki color as its first paint layer. So also does the other door in the collection, which appears to have been the entrance door onto the landing. The panels of both doors had a dark green as first paint color.



Figure C-48 Salvaged air lock doorway, door and section of board wall in North Carolina Maritime Museum.



Figure C-49 Close-up view of salvaged wall plate, board wall and door casing



Figure C-50 Interior face of salvaged lighthouse window sash in North Carolina Maritime Museum.

The interior surface of the salvaged window has no evidence of any color except white.

The cabinet in the Eighth Floor Watch Room has for its first colors a dark, cool pale gray for its top and white on the face of its doors; with just 5-6 paint layers, some layers may be missing, or the piece may be a later addition, or it was seldom painted.



Figure C-51 Watch Room cabinet.

The metal work of the interior contains uneven amounts of evidence of historic paint finishes. The handrail and the treads of the

spiral stairs contain only two layers of black paint. This absence of paint evidence is likely a measure of the effectiveness of the water blasting in the 1990s. In contrast, the central column has multiple paint layers present, probably because it was away from the focus of the object of the blasting, the walls. The column has evidence of two layers of dark green paint followed by numerous red-browns and grays. Because the dark green was applied over a red primer, probably indicates the green as the initial color.



Figure C-52 Red-painted iron work in 1976-1981 CALO file. (CALO Coll.)

Another element that contains a large number of paint layers, the earliest of which may be original, is the glazed lantern frame. Although the frame is composed of two different types of metal (ferrous vertical elements and copper-alloy horizontal elements) they both appear to have been painted consistently some version of white. Sometimes a red primer was also present.



Figure C-53 1976-1981-era photograph showing red primer on lantern floor (CALO Coll.)

Interior Features – By Room

First Floor: Unlike the elongated vertical spaces of the Second Floor through Six Floor, this space is closed off and feels like a room. The ceiling height is 10'-4" as measured from the top of the floor to the bottom of the floor plates of the Second Floor above. And unlike any other level in the Lighthouse, this room does not have interior passage to another floor level.

This area has always been designated for equipment and supplies. In recent decades, it has housed an emergency generator with fuel tank, batteries, electrical panels and the lighthouse power controller. Today, the electrical panels and power controller remain active and the remainder of the room is used for storage.

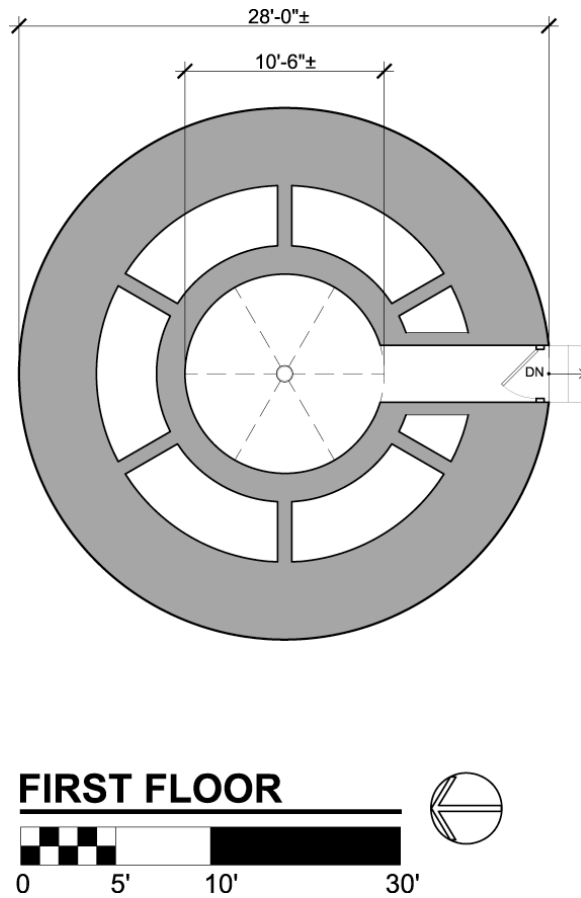

Figure C-54 First Floor Plan.

• **Flooring:** Handmade brick set in a mortar bed constitutes the flooring. The bricks are laid in a running bond pattern perpendicular to the doorway.

• **Baseboards:** There are no baseboards.

• **Walls:** The wall surface is constructed of handmade brick laid in a 1-to-5 common bond. In 1999 the brickwork was water blasted. The bricks' outer protective surfaces that faced the room were severely eroded in the process, exposing the softer interior of the bricks. This brickwork was then spot-repointed with a much too hard, impervious mortar. The combination of damaged brick

and impervious mortar is causing the bricks to suffer further damage from moisture migration and spalling.

• **Doors:** There is an original doorway opening on the south wall. (See above section *Exterior Features – Doors* for a description of this doorway.) Door hardware is brushed steel dating to the 1999 installation of the replacement door.

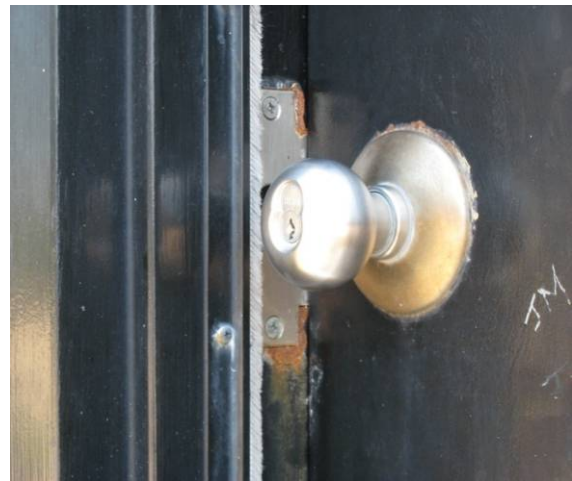

Figure C-55 Typical late-twentieth century, brushed steel doorknobs of First and Second Floor doors.

• **Windows:** There are no windows at this level.

• **Ceiling:** The underside of the cast-iron floor plates for the Second Floor serve as the ceiling for this room.

• **Column:** At this level, the iron column at the center of the room is fluted and measures 1'-4" in diameter. At about five feet above floor level, the column transitions to a 10" diameter. The column sits on a sandstone base that measures 2'-2" x 2'-2" x 3"

• **Stairs:** There are no stairs at this level.

• *Finishes:* The cast-iron column is painted and there are remnants of the early finishes on the brick wall surfaces. (See above section *Interior Features – Typical Characteristics: Finishes* for further discussion.)



Figure C-56 View of First Floor Room from Passageway.

• *Electrical Systems:* Most of the active components of the electrical system date to 1996-97. The wiring is contained in surface mounted metal conduit.

There are two, “jelly jar globe” type incandescent lighting fixtures. One is on the ceiling of the passageway from the door. The other is located near the center of the room.

There are two, 4'-0" long, ceiling-hung, two-bulb fluorescent lighting fixtures. One is in the passageway and the other is in the northeast quadrant of the room.



Figure C-57 Metal electrical conduit with incandescent and fluorescent light fixtures.



Figure C-58 Abandoned power controller and fuel cells.

There are two electrical panel boxes on the west wall of the passageway. The circuit breaker is identified as 100 amp 600 v I Phase.

The nonoperational emergency generator is just east of the center column. Its fuel tank is just north of the column.

The lighthouse power controller (USCG) is located on the masonry wall in the southeast quadrant of the room.



Figure C-59 Currently operational electrical panels on west wall of entrance passage.

Fuel cell batteries are on two racks west of the column.

• **Other Features:** The entrance passageway that connects the south side exterior doorway with the room is set on a north-south axis. The ceiling is spanned from side to side with sections of gray granite that also forms the lintel for the exterior doorway. The floor to ceiling height of this passage is 7'-6 1/2".

Second Floor: This is the room that provides the point of entry to all parts of the Lighthouse except the First Floor service area below.

Once inside the door, a short passageway, measuring 3'-0" wide with a 6'-6" ceiling

height, leads to the center core and its spiral staircase that connects with the levels above.

The height from top of this floor to the top of the Third Floor landing is 24'-2".

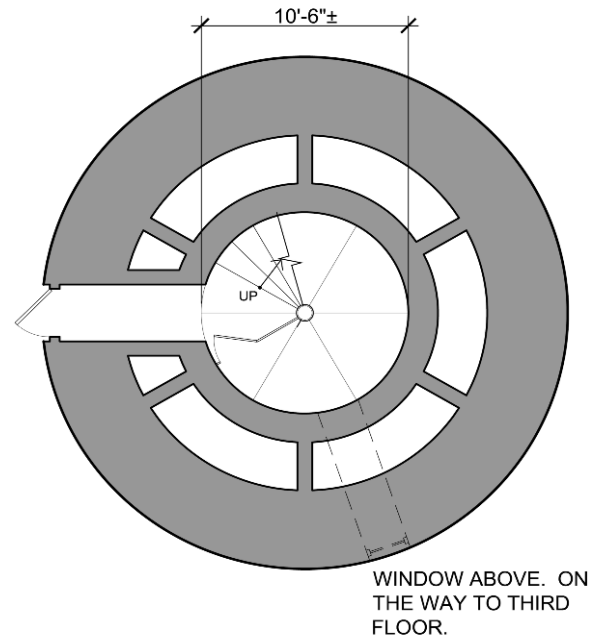

SECOND FLOOR

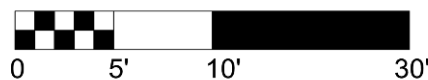

Figure C-60 Second Floor plan.

• **Flooring:** There are six, pie-shaped, iron floor sections providing a complete horizontal covering.

One of the six panels, the one that is in the southeast sector is slightly different in design and appears to be a much newer element than the others. (See *Interior Features – Staircase Landings* for further discussion.)

• **Baseboards:** There are no baseboards.

- *Walls:* The wall surface is constructed of handmade brick laid in a 1-to-5 common bond. (See above section *Interiors—Typical Characteristics: Brickwork* for a discussion of the wall condition.)

- *Doors:* There is an original doorway opening on the north wall. (See the section above *Exterior Feature –Doors* for a description of this doorway.) Door hardware is brushed steel dating to the 1999 installation of this door.



Figure C-61 Modified original exterior doorway and c.1914 interior door/transom framing in foreground.

Partway down the passageway are the framing remnants of a wood doorway and transom framing. The door and transom sash are missing. Although associated documentary evidence has not been found, the construction is similar to the 1914 work at the Service Room and may be remnants of another air lock, part of the effort of that period to better isolate and protect the new occulting device.

- *Windows:* En route up the spiral stairs to the Third Floor is a masonry opening measuring

2'-10" wide x 6'-11" tall framing a shaft that extends 6'-5" horizontally to the southwest exterior surface of the Tower. At the outer end of the shaft is a typical window unit, a replacement installed in 1999.

- *Ceiling:* Because there is more than a full 360-degree rotation in reaching the next floor landing, there is not a sensation of a ceiling height. The vertical distance from the top of the Second Floor to the top of the Third Floor landing is 24'-0".

- *Column:* At this level, the column at the center of the room is fluted and measures 10" in diameter.

- *Stairs:* The spiral staircase begins just to the left (east) as one enters the room.

There are thirty-five cast-iron treads between the Second Floor and Third Floor landings.



Figure C-62 Typical cast-iron treads of Spiral Staircase.

- *Finishes:* The cast-iron column, stair treads, landing and handrail are painted. There are

remnants of the early finishes on the brick wall surfaces. (See above section *Interior Features – Typical Characteristics: Finishes* for further discussion.)

- *Electrical Systems:* There are two, 4'-0"-long, two-bulb fluorescent lighting fixtures above the cyclone fence enclosure to the west side of the First Floor.



Figure C-63 Abandoned GE transmitter/receiver.

There is a single, 4'-0"-long, two-bulb fluorescent lighting fixture attached to the Third Floor framing to light the staircase.

Abandoned electronic equipment includes a General Electric Master Transmitter/Receiver.

- *Other Features:* The passageway that connects the north side exterior doorway with this room is set on a north-south axis. It measures 2'-11 1/2" wide. The ceiling is spanned from side to side with sections of granite, the outermost of which also forms the lintel for the exterior doorway. A granite panel also forms the door sill. The floor to ceiling height is 7'-7".



Figure C-64 Second Floor entrance passageway, spiral stairs, and modern steel fence enclosure.

On the west side of the Second Floor landing, cyclone fence material with posts, a gate, and wire mesh walls and ceiling create an enclosed secure room.

The masonry opening that connects the core with the window as discussed above is blocked at the interior core wall with two posts and a gate of metal cyclone-fence material. The gate is operable and in good condition.

There is evidence of the temporary 1863 stairs in the brickwork. Opposite the doorway there are two patches at the height of 11'-5" above top of the Second Floor level. Each patch is 8" tall. The width is irregular. (It is noteworthy that the wood joists for the Third Floor landing measure 2 7/8" x 8".)

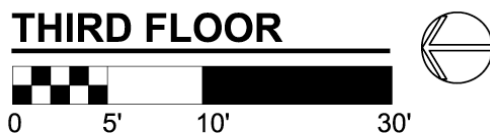
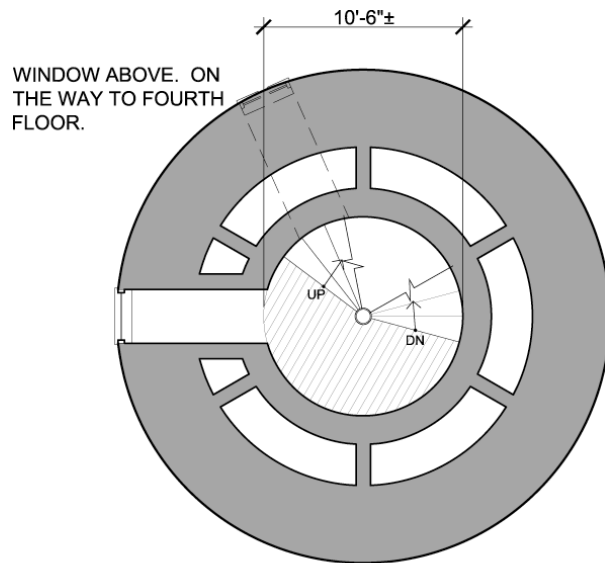

Figure C-65 Third Floor plan.

Third Floor: Although the Union forces submitted an assessment indicating the need for cast-iron floor panels to replace those that had been damaged by the Confederate explosion, this landing was not rebuilt accordingly. The reason is not clear from the documentary records.

The original I-beam was apparently reused. However, two wood joists measuring 2 7/8" x 8" were added and a new flooring of boards measuring 1 3/4" x 5" was installed in place of iron floor plates.

The height from top of this floor to the top of the Fourth Floor landing is 24'-2".



Figure C-66 Third Floor wood Landing.

- **Flooring:** The landing was rebuilt in the same location and configuration as shown in the prototype design. However, the landing is made of wood instead of cast-iron. The plank floor boards, each measuring 1 3/4" x 5", are laid running northwest to southeast with a bull nose edge.

- **Baseboards:** There are no baseboards.

- **Walls:** The wall surface is constructed of handmade brick laid in a 1-to-5 common bond. (See *Interiors* above for a discussion of the wall condition.)

- **Doors:** There is no doorway.

- **Windows:** At the Third Floor landing is a masonry opening measuring 2'-10" wide x 6'-11" tall forming a shaft that extends horizontally 5'-8". At the far end of the shaft is a typical window unit, a replacement installed in 1999.

En route up the spiral stairs to the Fourth Floor landing is a masonry opening measuring 2'-10" wide x 6'-4" tall framing a shaft that extends horizontally 5'-0" to the northeast. At

the far end of the shaft is a typical window unit, a replacement installed in 1999.



Figure C-67 Detail of bull nose edging of Third Floor landing.

- *Ceiling:* Because there is more than a full 360-degree rotation in reaching the next floor landing, there is not a sensation of a ceiling height.
- *Column:* At this level, the column at the center of the room is fluted and measures 10" in diameter.
- *Stairs:* There are thirty-five cast-iron treads between the Third Floor and Fourth Floor landings. The Union documents record 61 cast-iron steps were to be ordered as replacements for the ones damaged and three extra steps, very clean and without wear marks, presumably unused, were discovered stored on the Second Floor landing. Although it is likely that some of the thirty-five treads in place are replacements dating to 1867, no

distinction in physical characteristics or wear pattern were noted. Disruption of the masonry where the treads connect to the core wall during the 1999 inspection also hampers determination of which treads are the 1867 replacements and which are the originals.

- *Finishes:* The cast-iron column, stairs, landing and handrail are painted and there are remnants of the early finishes on the brick wall surfaces. (See above section *Interior Features – Typical Characteristics: Finishes* for further discussion.)

- *Electrical Systems:* There is a single 4'-0"-long, two-bulb fluorescent lighting fixture attached to the underside of the framing of the Fourth Floor landing to light the staircase below.

- *Other Features:* There are two sets of evidence of the 1863 temporary stairs in the core wall brickwork. One set is along the northeast surface of the wall, at the same level as the 8" deep joists that support the Third Floor landing. Each of the two patches is 8" tall and the width is irregular.



Figure C-68 Two masonry patches presumably associated with the 1864 framing for temporary stairs.

The second set of evidence consists of five patches. All are at a height of 11'-9" above the top of the Third Floor landing. Two are on the north wall surface and three are opposite on the south wall surface. All five are similar to the other patches found lower at the level of the Third Floor landing and between the Second Floor and Third Floor landings.

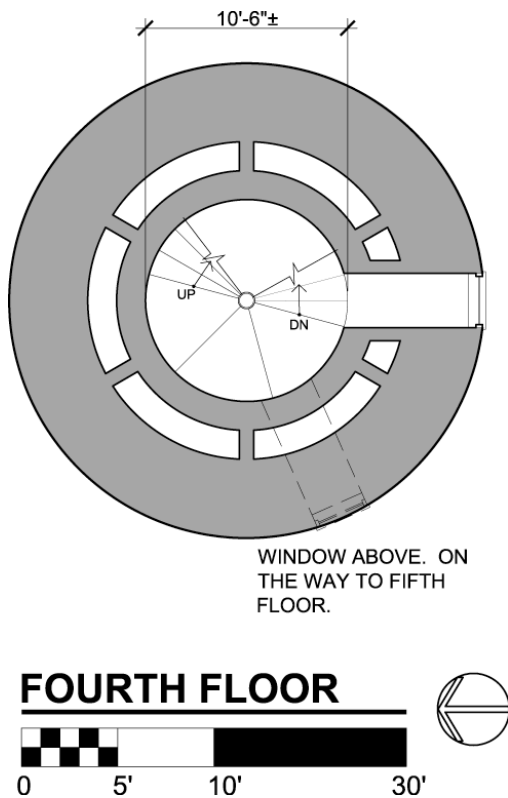

Figure C-69 Fourth Floor plan.

Fourth Floor: This is an intermediate level without particular distinction.

The height from top of this floor to the top of the Fourth Floor landing is 24'-2".

- **Flooring:** There are three, pie-shaped, cast-iron floor plates spanning horizontally across roughly half the available space as designated in the prototype plan.

- **Walls:** The wall surface is constructed of handmade brick laid in a 1-to-5 common bond. (See *Interior Features – Typical Characteristics: Brickwork* for further discussion.)
- **Doors:** There is no doorway.
- **Windows:** At the landing is a masonry opening measuring 2'-10" wide x 6'-11" tall forming a shaft that extends horizontally 4'-8½" to the south exterior surface of the Tower. At the outer end of the shaft is a typical window unit, a replacement installed in 1999.

En route up the spiral stairs to the Fifth Floor is a masonry opening measuring 2'-10" wide x 6'-11" tall forming a shaft that extends horizontally 4'-1" to the southwest exterior surface of the Tower. At the outer end of the shaft is a typical window unit, a replacement installed in 1999.

- **Ceiling:** Because there is more than a full 360-degree rotation in reaching the next floor landing, there is not a sensation of a ceiling height.

- **Column:** At this level, the column at the center of the room is fluted and measures 10" in diameter.

- **Stairs:** There are thirty-five cast-iron treads between the Fourth Floor and Fifth Floor landings.

- **Finishes:** The cast-iron column, stairs, landing and handrail are painted and there are remnants of the early finishes on the brick wall surfaces. (See above section *Interior Features – Typical Characteristics: Finishes* for further discussion.)

- *Electrical Systems:* There is a single, 4'-0" long, two-bulb, fluorescent lighting fixture attached to the framing of the Fifth Floor landing to light the staircase below.

Fifth Floor: This is an intermediate level without particular distinction.

The height from top of this floor to the top of the Fourth Floor landing is 24'-2".

- *Flooring:* There are three, pie-shaped, cast-iron floor plates of the typical design spanning horizontally roughly half the available space in the location designated in the prototype plan.

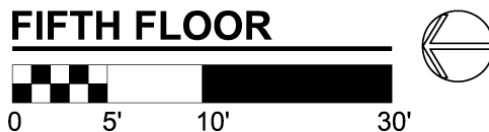
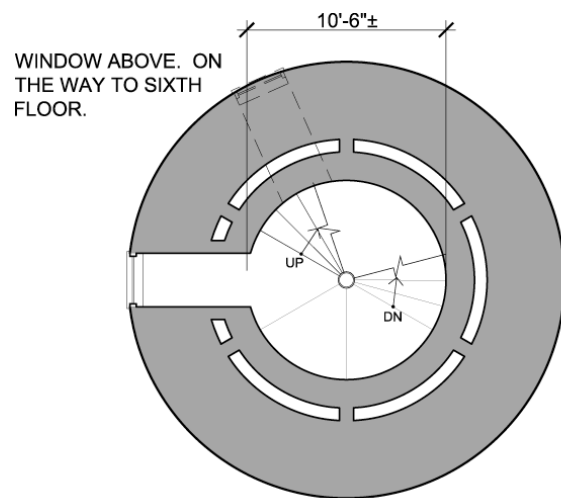

Figure C-70 Fifth Floor plan.

- *Baseboards:* There are no baseboards.
- *Walls:* The wall surface is constructed of handmade brick laid in a 1-to-5 common bond. There is a large amount of the spalling

of bricks between the Fifth Floor and the Sixth Floor. (See section above *Interior Features – Typical Characteristics: Brickwork* for further discussion.)

- *Doors:* There is no doorway.

- *Windows:* At the landing is a masonry opening measuring 2'-10" wide x 7'-0" tall forming a shaft that extends horizontally 3'-5" to the north exterior surface of Tower. At the outer end of the shaft is a typical window unit, a replacement installed in 1999.

En route up the spiral stairs to the Fifth Floor is a masonry opening measuring 2'-10" wide x 6'-0" tall forming a shaft that extends 2'-10" horizontally to the northeast exterior surface of the Tower. At the far end of the shaft is a typical window unit, a replacement installed in 1999.

- *Ceiling:* Because there is more than a full 360-degree rotation in reaching the next floor landing, there is not a sensation of a ceiling height.

- *Column:* At this level, the column at the center of the room is fluted and measures 10" in diameter.

- *Stairs:* There are thirty-five cast-iron treads between the Fourth Floor and the Fifth Floor.

- *Finishes:* The cast-iron column, stairs, landing and handrail are painted and there are remnants of the early finishes on the brick wall surfaces. (See above section *Interior Features – Typical Characteristics: Finishes* for further discussion.)

- *Electrical Systems:* There is a single, 4'-0" long, two-bulb, fluorescent lighting fixture attached at the bottom of the framing of the

Fifth Floor landing to light the staircase below.

Sixth Floor: This is an intermediate level without particular distinction.

The height from top of this floor to the top of the Seventh Floor landing is 24'-2".

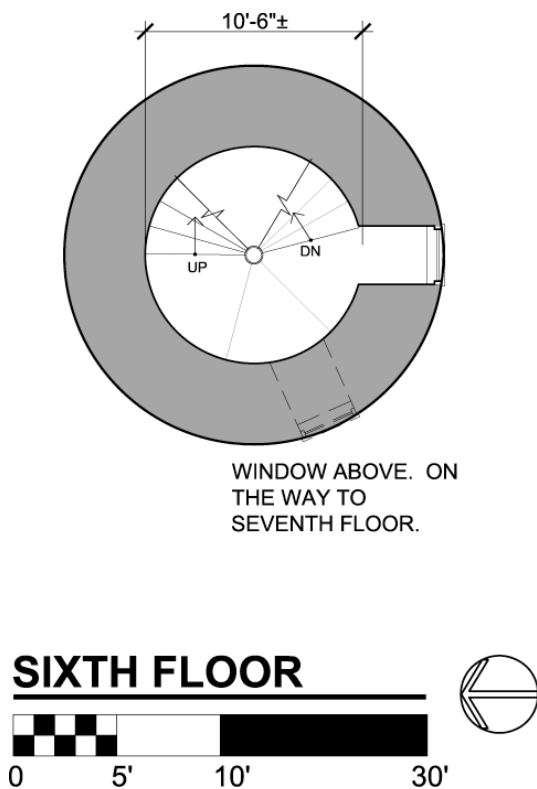

Figure C-71 Sixth Floor plan.

• **Flooring:** There are three, pie-shaped, cast-iron floor plates of the typical design spanning horizontally roughly half the available space in the location designated in the prototype plan.

• **Baseboards:** There are no baseboards.

• **Walls:** The wall surface is constructed of handmade brick laid in a 1-to-5 common bond. (See section above *Interior Features – Typical Characteristics: Brickwork* for further discussion.)

• **Doors:** There is no doorway.

• **Windows:** At the landing is a masonry opening measuring 2'-10" wide x 6'-6" tall forming a shaft that extends horizontally 2" – 5" to the south exterior surface of the Tower. At the outer end of the shaft is a typical window unit, a replacement installed in 1999.

En route up the spiral stairs to the Seventh Floor is a masonry opening measuring 2'-10" wide x 6'-11½" tall forming a shaft that extends horizontally 1" – 9" to the southwest exterior surface of the Tower. At the far end of the shaft is a typical window unit, a replacement installed in 1999.



Figure C-72 Original cast-iron steps leading down from Seventh Floor Landing.

• **Ceiling:** Because there is more than a full 360-degree rotation in reaching the next floor landing, there is not a sensation of a ceiling height.

- *Column:* At this level, the column at the center of the room is fluted and measures 10" in diameter.
- *Stairs:* There are thirty-five cast-iron treads between the Sixth Floor and the Seventh Floor. This is the highest run of the spiral staircase.

One step is missing half of its tread and is supported by an added vertical brace. This modification was made in 1914 to two treads in order to accommodate the chains for the new oscillating device.

A number of the treads have a metal strap added to make connection between steps in sequence. The date of installation of this additional support is unknown.



Figure C-73 1914 tread modification to accommodate the weight for oscillating mechanism.

- *Finishes:* The cast-iron column, stairs, landing and handrail are painted and there are remnants of the early finishes on the brick wall surfaces. (See above section *Interior Features – Typical Characteristics: Finishes* for further discussion.)
- *Electrical Systems:* There is a single, 4"-0" long, two-bulb, fluorescent lighting fixture attached to the bottom of the framing of the Seventh Floor landing to light the staircase below.



Figure C-74 Metal strap reinforcement of unknown installation date.

Seventh Floor (or Service Room): The spiral staircase ends at this level. This is the only location where an historic frame wall appears.

The height from top of this floor to the top of the Eighth Floor landing is 8"-0".

- *Flooring*: There are three wedge-shaped cast-iron floor plates of the typical design spanning horizontally roughly half the available space in the location designated in the prototype plan.

- *Baseboards*: There is a baseboard/wall plate for the board wall. Made of wood and dating to 1914, it measures 1½" tall and 4" wide with a slot in the center of the top surface to hold in place the board wall. A horizontal bevel edge runs along face of both sides of the baseboard/wall plate. (See *Appendix A: Documentation Drawings*.)

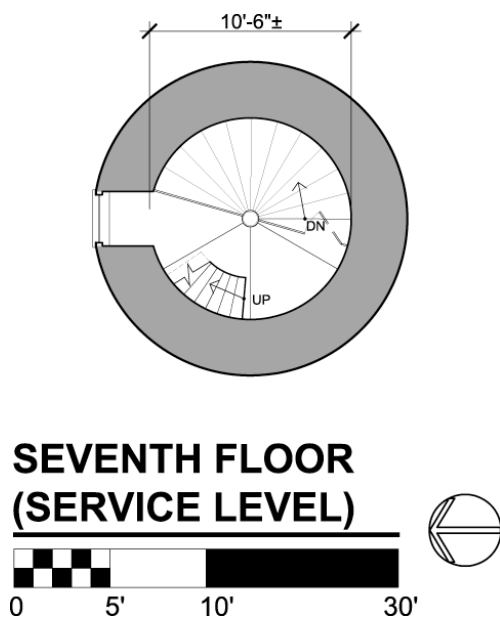

Figure C-75 Seventh Floor plan.

- *Walls*: The exterior wall surface is constructed of handmade brick laid in a 1-to-5 common bond. (See section above *Interior Features—Typical Characteristics: Brickwork* for further discussion.)

A board wall runs along the edge of the flooring. The boards, aligned vertically, are

tongue-and-groove measuring 7/8" x 4¾" with a 1/8" edge bead and are assembled with wire nails. This wall is shown as an existing wall on the 1913 drawings which call for its repair and construction of an adjoining airlock, as well as an air lock on the newly expanded Observation Deck. These air locks were probably meant to isolate and protect the incandescent oil vapor lamp and the new occulting mechanism. Construction of the new Observation Deck and the two air locks was completed in 1914. At some unknown date, perhaps during the 1989 installation of the metal bracing, this Service Room air lock was removed.

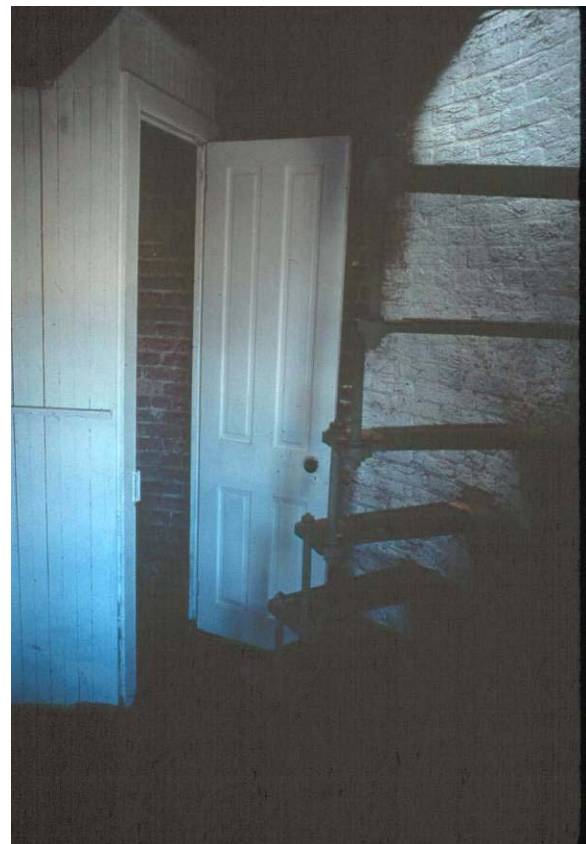

Figure C-76 Air lock in place in 1976-1981. (CALO Coll.)

The North Carolina Maritime Museum has in its collection a complete doorway with door

and a portion of the attached board wall. There is also a second door. These elements are identified as originating at the Cape Lookout Lighthouse "Storage Room" and were accessioned in 2001. The board wall at the museum matches this remaining board wall at the lighthouse in types of material, methods of construction and paint finishes. The Museum's board wall and doorway appears to be part of the missing air lock. In addition, it appears that in situ wall was not repaired as called for on the 1913 plans but was rebuilt. Both the wall in situ and the air lock were constructed in 1914.



Figure C-77 1914 board wall and doorway at Seventh Floor landing. Note 1989 steel reinforcement added at masonry perimeter.

• **Doors:** There is a doorway in the board wall at the top of the spiral stairs. The doorway was framed for a 2'-0" x 7'-0" x 1¼" door, now absent. The second four-panel door in

the North Carolina Maritime Museum matches these dimensions as does its hinges and rim lock. This door retains most of its original 1914 hardware. It has a sheet metal-clad, box lock measuring 3¼" wide x 4½" tall. The sheet metal doorknobs are probably replacements.



Figure C-78 Salvaged four-panel door; detail images of rim lock with sheet metal doorknob and two-knuckle brass hinge. (North Carolina Maritime Museum Collection)

This door also retains its two, 2½" tall, two-knuckle, brass hinges. The keeper for the box lock remains on the doorway jamb still in

place in the lighthouse. The door casing, appearing on both sides of the doorway, measures $\frac{3}{4}$ " x $3\frac{1}{2}$ " with an edge bead of $\frac{3}{8}$ " and is mitered cut at the corners.



Figure C-79 Seventh Floor door casing. Note miter cut of corner.



Figure C-80 Door threshold and board wall at Seventh Floor, the top landing of the spiral stairs.

The second door in the North Carolina Maritime Museum collection measures 1'-11 $\frac{3}{4}$ " wide x 6'-9 $\frac{1}{2}$ " tall and $\frac{1}{4}$ " thick. It retains its sheet-metal clad box lock measuring $\frac{3}{4}$ " wide x 4 $\frac{1}{4}$ " tall and two black, mineral door knobs. There are two, three-knuckle, iron hinges with $\frac{3}{8}$ " ball hinge pins, also typical for the 1914 period.

- **Windows:** A typical, double-hung, replacement window unit installed in 1999 is located along the north wall of this landing.



Figure C-81 Door latch keeper matches rim lock of extra door in North Carolina Maritime Museum collection.

- **Ceiling:** The underside of the six, pie-shaped, cast-iron floor panels for the level above form the ceiling for this space.
- **Column:** At this level, the 10" fluted column at the center of the room transitions to a 10" smooth column, the base for the pedestal that holds the beacon.
- **Stairs:** The spiral staircase does not continue beyond this Seventh Floor landing. Instead, the original, boot-shaped, 2'-2"-wide cast-iron ladder stairs, the design of which is unique to this level, begins along the east exterior wall (whereas the prototype plan has the steps beginning along the northeast wall) and connects with the Eighth Floor landing. The wider flange of each tread is imbedded in the masonry wall, while the narrow end is

connected by separate 1" diameter rods with both the step above and the step below. The rise between adjoining treads is 9". Two of the seven treads have been partially removed to accommodate the 1989 steel bracing.



Figure C-82 Original cast-iron ship's ladder stairs connecting Seventh Floor Service Room to Eighth Floor Watch Room.

- **Finishes:** The cast-iron column, stairs, landing plates and handrail are painted. The board wall is painted. In addition, there are remnants of the early finishes on the brick wall surfaces. (See above section *Interior Features – Typical Characteristics: Finishes* for further discussion.)

- **Electrical Systems:** There are no components of the electrical system at this level.

- **Other Features:** The handrail along with the spiral staircase terminates at this level.

A reinforcing, tubular-steel frame was installed in 1989 at this and both the Eighth Floor (Watch) and Ninth Floor (Lantern) levels. (See *Appendix B: Structural Assessment & Carrying Capacity Analysis* for further discussion.)

Eighth Floor (or Watch Level): This room is immediately below the Lantern Floor where the beacon is located. It also has the observation deck immediately adjacent with access only through a doorway from this room.

The height from top of this floor to the top of the Lantern landing is 7'-2".

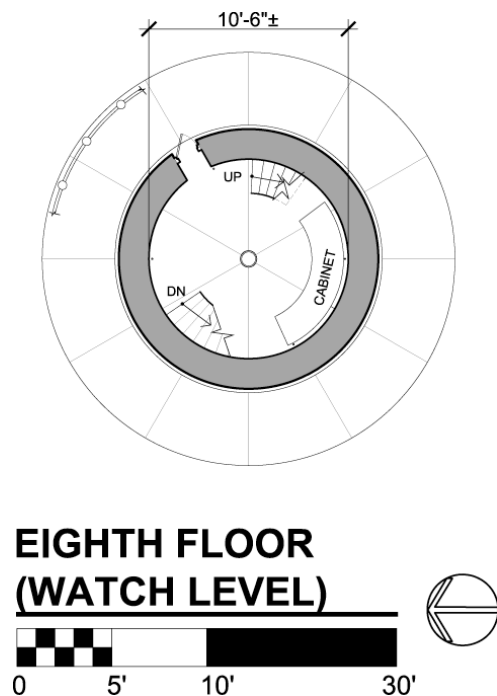

Figure C-83 Eighth Floor plan.

- **Flooring:** There are six wedge-shaped, cast-iron floor plates of the typical design creating a full landing, as designated in the prototype plan. (One floor pan has a cast opening for

stair connection to the Seventh Floor or Service Level immediately below.)



Figure C-84 Floor cuts for 1914 drive chain for occulting mechanism.

Near the center column there are two small holes cut in 1914 for the occulting chain.



Figure C-85 Jacking of iron floor plate at doorway to Observation Deck.

At the hatch to the Observation Deck, there is jacking of the iron floor plate with one section of broken plate sitting proud of the floor about 1¾".

- *Baseboards:* There are no baseboards.
- *Walls:* The exterior wall surface is constructed of handmade brick laid in a 1-to-5 common bond. (See section above *Interior Features – Typical Characteristics: Brickwork* for further discussion of these wall conditions.) In addition, vertical cracks are present in numerous locations, some of which extend from floor to ceiling and through to the exterior wall surface.

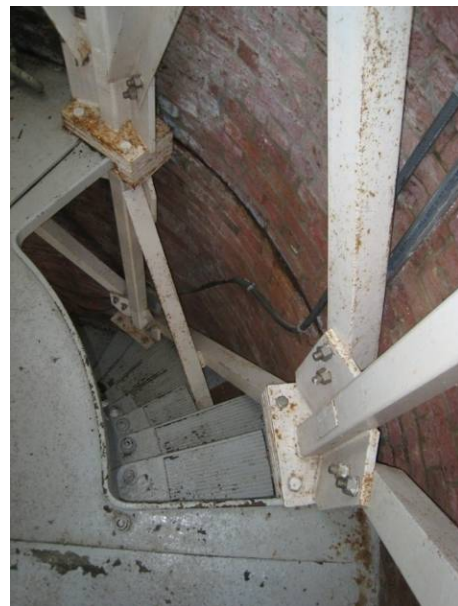

Figure C-86 Cast-iron floor plates of Eighth Floor Watch Room looking to Seventh Floor Service Room.

- *Doors:* There is an original doorway opening, with granite lintel and sill, along the northeast wall surface leading to the Observation Deck. The opening was partially infilled in 1914. At an unknown time a ship's hatch was installed. The current hatch is cast aluminum, was installed c. 1996 according to park personnel, and measures 1'-6" x 3'-0". The original masonry doorway opening is intact and measures 2'-3½" wide x 4'-9" tall. (See above section *Exterior Features – Doorways* for further discussion.)



Figure C-87 Reinforcing steel added in 1989 partially blocks ship's hatch to Observation Deck.



Figure C-88 Column and underside of cast-iron platform for beacon.

- **Windows:** There are no windows at this level.
- **Ceiling:** Underside of cast-iron beacon platform forms the ceiling for this room.

- **Column:** At this level, the column at the center of the room has a 10" diameter and a smooth surface, as was transitioned from a fluted surface at the Seventh Floor.



Figure C-89 Original cast-iron ship's ladder to Lantern.

- **Stairs:** The original cast-iron ladder stairs provide the access to the Lantern. These steps are also in the shape of a boot like those at the level below, but narrower and with a greater rise between treads. The steps begin along the southeast exterior wall (whereas the prototype plan has the steps beginning along the northeast wall.) Each tread measures 1'-9 1/2" wide x 3 1/2 to 4 1/2" deep and 1" thick. The wider flange of each tread is connected to the masonry wall, while the narrow end is connected by two, separate 1" diameter rods with both the step above and the step below. The riser height is 9 1/2". Portions of two of the eight treads have been removed to

accommodate the steel reinforcement framing installed in 1989. Otherwise, this original ladder stair is intact and in good condition.



Figure C-90 Close-up view of ship's ladder to Lantern.

- *Finishes:* The cast-iron column, stairs, and floor plates are painted.

In addition, there are remnants of the early finishes on the brick wall surfaces. (See above section *Interior Features—Finishes.*)

Characteristics: See Appendix D: *Materials Analysis.*

The wood cabinet is painted.

- *Electrical Systems:* There are no elements of the electrical service at this level.



Figure C-91 Two-door cabinet in Eighth Floor Watch Room.

- *Other Features:* There is an early, if not original, cabinet along the south wall. Built on the curve to fit against the exterior masonry wall, it measures 2'-8½" high x 1'-8" deep x 7'-6½" at longest length. Its panels are made of boards measuring 7/8" x 3¼" or 4¼" with a ¼" edge bead. There are two cabinet doors, each constructed with inside surface battens. Each door has two, 3" tall, five-knuckle cast-iron hinges and a wood door pull. The cabinet's counter surface has a 5/8" radius bull nose at the forward and side edges. Towards the back of this counter top are paint ridges indicating three vertical supports for bookshelves, now missing.



Figure C-92 Curved interior face of board-and-batten cabinet door.



Figure C-93 Ghost marks of missing shelving supports.



Figure C-94 Cabinet's five-knuckle hinge and batten.

There are four, adjustable, brass air vents set equidistant around the room and extending through to exterior face of the masonry wall.



Figure C-95 Brass manual control for adjusting air flow.

Ninth Floor (or Lantern Level): The glass and metal framing of the sixteen-sided wall enclose the beacon and provide a clear view in all directions.

- ***Flooring:*** There are two portions, both of cast iron. The outer walkway is 1'-9" wide. A 6" gap separates it from the center platform that holds the light.

- ***Baseboards:*** There are no baseboards, *per se*, but there is a 5" wide masonry curb upon which the iron and glass encircling wall sits.

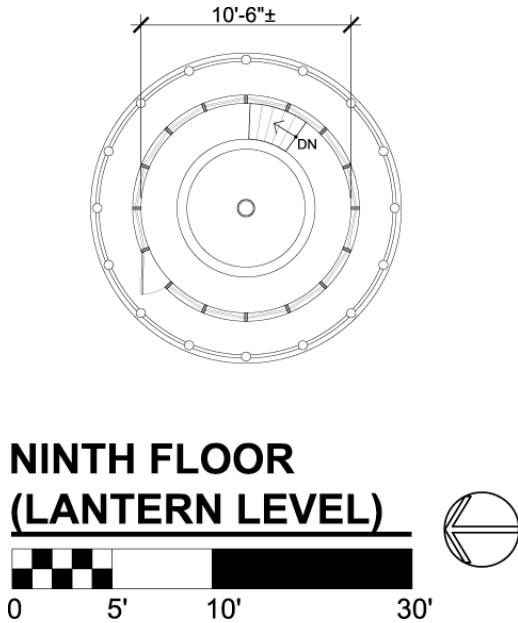

Figure C-96 Ninth Floor plan.

• **Walls:** The vertical framing elements are cast iron. The connecting horizontal framing elements are brass with small refined details. There is much corrosion and surface loss of the cast iron, especially at the floor plate and at some connection points with the brass. A few of the glass panels are damaged.



Figure C-97 Center cast-iron platform for beacon.

• **Doors:** Set in one of the 16 exterior wall sections is an original doorway with a brass and glass door that connects with the Balcony. Though heavily coated with paint layers that make operation difficult, the door appears to be in sound condition.



Figure C-98 Deteriorated iron framing.

• **Windows:** The vertical planes of glass in the thin metal framing of the walls create, in effect, a glass enclosed room.



Figure C-99 Close-up view of horizontal framing of a cast copper-based metal.

- *Ceiling:* Thin, pie-shaped, copper panels form the ceiling.



Figure C-100 Metal ceiling panels.

- *Stairs:* An opening in the perimeter cast-iron walkway allows access to the original cast-iron ladder stairs that connect with the Eighth Floor (Watch Level). The opening is partially blocked by framing for the 1989 steel reinforcement.



Figure C-101 Original cast-iron ship's ladder connecting to Lantern floor plates.

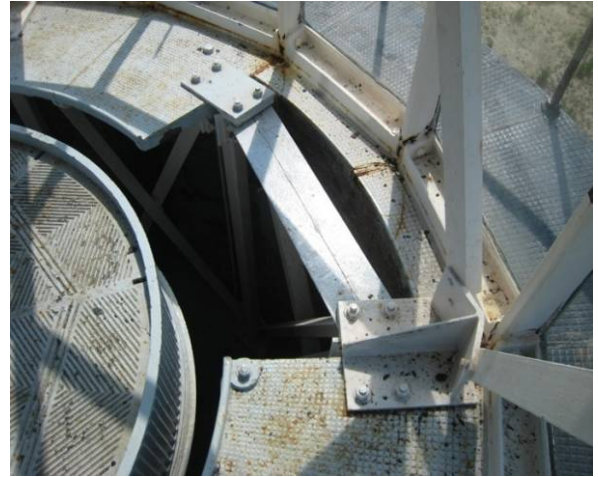

Figure C-102 Access to stairs to Watch Level partially blocked by 1989 reinforcing steel.

- *Finishes:* The cast-iron ladder stairs, curb, walkway and pedestal are painted.

The wall framing and ceiling panels are painted.

In addition, the housing for the beacon is also painted.

- *Electrical Systems:* The beacon operates 24 hours per day.



Figure C-103 Beacon.

Summary of Conditions

The lighthouse retains a large percentage of building fabric from the 1859 initial construction, the 1867 repair of Civil War damages, the 1871 exterior painting campaign which established the distinctive black-and-white diamond pattern, and the 1914 building modifications. The later manifestations, as well as the initially constructed design, are tangible evidence of significant chapters in the building's evolution. These components are important character-defining elements, worthy of preservation.

While the lighthouse's historic character is largely intact, there are physical conditions which limit the building's use either because of the constraints of the initial design or because of deteriorated condition.

Limitation of Inherent Design Characteristics

As a working lighthouse at mid-nineteenth century, the building was designed for a small crew working in tight spaces. Accordingly, the major internal circulation route, for five levels, is the spiral staircase. It is necessarily narrow, the distance between steps is steep, and the path of travel is long. Further, the treads are awkward for navigating, pie-shaped, radiating from the point of attachment to the center column. A single handrail, attached to the masonry along the outer edge of the treads, provides support to steady the traveler.

The two levels of ladder stairs above the spiral staircase are even more narrow, without handrail, and steeper, though the distance of travel is much less.

Doorways and passages are likewise narrow and sometimes small.

And natural light, provided by the ten small windows along the route of vertical travel, is limited, even under the best of conditions.

Deteriorated Building Materials

With the repeated loadings of foot traffic over some one hundred and fifty years of use, the treads of the spiral stairs have incurred some degree of fatigue. The resultant "bounce" of some treads is noticeable. Concern for the strength of these steps and thereby the safety of the occupants, led to the park's closing of the lighthouse interior to public visitation in January 2008 and subsequently to the preparation of this HSR.



Figure C-104 Extensive corrosion of cast-iron framing.

The inherent design characteristics can be improved with tread reinforcement, artificial lighting, added handrails and administrative policy. The physical modifications can be accomplished with sensitive applications that respect the character-defining historical qualities of the lighthouse.

Other deterioration is also present and potentially just as serious though less obvious to the casual observer. Two of the most serious occurrences are in certain iron elements and the masonry.



Figure C-105 Through-wall cracks in masonry at top of Tower.

The iron elements of the Lantern including wall plate, framing struts, and Gallery walkway plates have extensive advanced deterioration. In addition to the damages to these elements, the expansion caused by the deterioration process is not only damaging adjoining material, most notably the top of the masonry Tower, but also allowing moisture to freely enter, causing yet more damage. The prime example of suspected collateral damage is imbedded in the upper masonry at Watch Level, a tension ring presumably made of iron as was typical of the period and indicated on

the prototype drawings. The long, vertical cracks in the masonry from top of the Tower down to the Seventh Floor area is likely the result of the expansion from a deteriorating tension ring.

The 1989 installation of steel supplemental framing and tie rods provides much-needed reinforcement, but it does not address the cause of the problems. The damaged iron will continue to deteriorate and weaken, and in expanding it will continue to cause collateral damages as well. The only long-term solution and ultimately the most cost-effective, is to make repair to the damaged iron.



Figure C-106 Underside of Lantern Gallery reinforced in 1989.

The second area of concern is the brickwork of the Tower. The bricks are handmade and low-fired, creating an irregular building block with an outer protective crust and softer interior core. The masonry was laid in a natural cement mortar which has proven to be quite durable.

Unfortunately, both the interior surface of the core wall and the exterior surface of the

exterior wall have been water blasted. The effect as seen on the interior of the lighthouse, is that the protective outer surfaces of the bricks have been damaged, exposing the less-durable interior material.



Figure C-107 Displaced masonry and supplemental tie rods.

Compounding this vulnerability has been the repointing of masonry with a too rigid and impermeable a mortar, at least on the interior, and the installation on the exterior of a non-breathable paint coating. Essential remedial actions include the reapplication of a breathable shelter coating to the interior

brickwork, removal of incompatible mortars/reapplication of suitable mortar, and removal of the non-breathable exterior coating/replacement with a compatible coating.



Figure C-108 Non-breathable coating on exterior masonry.

PART II: TREATMENT AND USE

A. ULTIMATE TREATMENT & USE

Building Fabric: Significance

The great majority of the building fabric of the Cape Lookout Lighthouse dates to the initial construction of 1859 and the post-Civil War repairs-in-kind of 1867. Even today, the building at first look appears pristine, evoking the character of its earliest construction period.

The structure's largest mass of material is the masonry work. The original load-bearing brick construction, punctuated with granite lintels at the fenestration, remains intact. The most distinctive exterior features are the striking black-and-white painted diamond pattern of the tower and the black lantern. The lantern likewise is complete, inside and out, with the exception of its lens and associated lighting equipment.

The most impressive feature inside the lighthouse is the cast-iron spiral staircase. Five levels rise some one hundred and twenty feet. The stairs are indistinguishable though some sixty of the two hundred ninety treads are actually 1867 replacements matching those destroyed in an attack during the Civil War. Two landings also are replacements; the cast-iron landing at the second floor strongly resembles the originals in appearance, while the third-floor landing is inexplicably but almost unnoticeably made of wood. Also impressive are the short runs of cast-iron ladder stairs at the service and observation levels. These stairs

also are original, although two treads in each run were modified in subsequent repairs.

These original and early features all have architectural and historical significance.

There have been only a few additions and changes to the design of the lighthouse. Most of these modifications are minor and relatively indistinguishable, visually, from the early building components. At the watch level, for example, the observation deck was widened in 1914. Its small access door was replaced. In part due to its height above ground level, these changes are hardly noticeable.

Also during the 1914 remodeling campaign, two board walls, each with doorway, were built at the seventh-floor service level. The wall enclosing the landing was rebuilt while the other was built anew to create an air lock, presumably to isolate and protect a new occulting mechanism. Today, the enclosing wall and doorway, without door, remain. Part of the air lock wall, its doorway and door are at the North Carolina Maritime Museum in nearby Beaufort, along with the door for the rebuilt enclosure wall.

These 1914 modifications had a significant impact on the architectural character of the lighthouse and with age have acquired historical importance. They are valuable as tangible evidence of the evolution of the lighthouse prompted by changes in its use.

In 1999, all ten wood windows were replaced. The replacement units, also of wood and consisting of six light sashes, are very similar to the originals in overall design characteristics. The replacements are valuable features because they continue to portray the historical character of the lighthouse.

In contrast, certain other recent modifications are out of character and quite noticeable. One example is the 1999 flat-panel steel entrance doors at first- and second-floor levels. They are stylistically incongruous with the historical character of the lighthouse. Equally distracting is the second-floor room created of modern galvanized mesh fence. The wood entrance stairs, on the other hand, are not especially distracting but are ill-suited in their modern-dimensioned, treated lumber.

The most jarring of the intrusions is the steel square pipe and angle reinforcement at the interior of the lantern, the watch level, the service level, and area immediately below. Although added 1989 to serve an important purpose, its presence is not only a major visual intrusion but also a physical barrier to passage through the interior spaces and through the doorway to the exterior watch-level observation deck.

These recent modifications addressed physical needs but do not possess historical significance, and in some instances detract from the building's historic character.

Building Fabric: Condition

While much of the original and early building fabric is intact and stable, there are two localized areas of significant

deterioration, the metal lantern and the masonry of the top of the lighthouse tower. The two areas adjoin each other and the problems are at least partially interrelated.

At the lantern, the ferric-based framing elements show numerous pockets of severe rusting. The lantern's iron sill plate, which attaches to the top of the masonry, has the most serious deterioration with extensive rust and severe buckling.

The top of the masonry tower, immediately below this plate and extending downward as far as fifteen to twenty feet, has sections of displaced material as well as vertical cracks. Some of the cracks and displacement are clearly associated with the jacking of the lantern's iron sill plate. Some of these damage may be associated with the deterioration of an iron tension ring, unseen but identified on the prototype drawing as imbedded in the masonry. These damages also may be associated with a progressive inability of the deteriorating masonry and iron to resist significant lateral loading associated with storms. And the damages could be the result of a combination of these factors.

The steel framing installed in 1989 addressed these deteriorated conditions of lantern and masonry by providing additional support. Although this framing does provide valuable temporary support, it does not address all the causes of the damages. The installation also is a major intrusion, physically and visually, that adversely affects the opportunities for visitation and interpretation.

A third set of conditions is less urgent but will lead to serious deterioration if not addressed. On the masonry exterior, an impermeable paint coating has been applied. On the interior masonry surface, there has been considerable repointing of mortar joints with a rigid impermeable mortar. These two systems of replacement paint and mortar overpower the inherent qualities of soft brick and the permeable and flexible mortar. As a result, moisture is unable to migrate out through the mortar for evaporation, and instead, the moisture in the masonry moves through the brick. This moisture migration is causing significant spalling in the brickwork.

Other instances of deterioration are minor and localized. The two modern steel entrance doors are severely rusted and need to be replaced. Portions of the wood entrance stairs are built on earlier stair framing which has deteriorated to the point of requiring replacement.

Change in Use

The lighthouse was designed to be the work area for a small crew performing important tasks for safe coastal navigation at mid-nineteenth century. Technological advances reduced and eventually eliminated the need for daily crew activity both on the site and in the building. The lighthouse nonetheless retains its original physical qualities and has remained a most familiar and beloved icon of the East Coast. It has also become a major tourist destination.

The Challenge

The Park Service has the challenge of balancing its responsibility to protect

important cultural resources with its responsibility to educate the public.

While there are many ways to address education short of actual visitation, there is no question that a trip to South Core Banks and a visit to the lighthouse is a most impressive experience. However, access to the site and throughout the building can be problematic for some visitors. It is arduous; some should not attempt it at all.

The trip to the island is by small boat. Once ashore, a choice of a small board walkway or beach paths leads to the base of the building. The first floor service room is the most readily accessible interior space, up two steep steps from grade. The remainder of the building is much more difficult, accessed by an exterior wood stairs to the main entrance at second floor level. Once inside, there are five sections of a spiral staircase, each section extending vertically almost twenty-five feet between landings. The steps are steeper than today's convention and the winding pie-shaped treads require concentration. The distance of travel is physically demanding.

Along the way, a few of the building's ten windows align with stair landings and are reached by narrow corridors in the masonry. Windows are small and give an impressive though limited view. The major reward of the journey, undoubtedly, is the view at observation deck.

The next two landings are reached by ladder stairs. Both runs are short, each less than ten feet in vertical height, but the steps are steeper and the treads both more shallow and narrow.

The next-to-last run of stairs opens into the watch room. From there, access to its observation deck is yet another hurdle, with its entrance through a small masonry opening with ship's hatch. The 360-degree view is spectacular.

While repeated ascent through these interior work spaces was common for the small crew of nineteenth-century light keepers, it is a physical challenge for most twenty-first century visitors.

In accommodating the modern visitor, the Park Service must keep ever in mind the difficulty of the long ascent, sometimes circular as well as steep. It is also important to be mindful of the limitations of the building fabric itself. The design of the interior, with its narrow corridors, stairs, and wedge-shaped treads, tends to align the occupants in single file. In addition, the engineering assessment of the spiral stair carrying capacity, contained in *Appendix B*, concludes that even with reinforcement of the stair treads, regular inspections will be necessary; the change in occupancy from small work crew to public visitation will dramatically increase loading and consequently diminish the material life expectancy.

Another limiting factor is the International Building Code, which governs the use of this lighthouse. Its provisions regulate occupancy by total number as well as by building section. No more than twenty-five persons may occupy the building at one time and of those no more than six may be at the seventh floor landing and higher. See *Appendix C* for a partial listing of applicable code requirements. Compliance with the building code is mandatory.

Essential repairs for the conservation of the lighthouse have been enumerated above. Some are urgently needed. There are also critical modifications needed to make the building safer for the larger groups that come with public visitation. The most cost-effective approach is to implement all repairs and modifications in a single campaign.

Recommended Ultimate Treatment

The Recommended Ultimate Treatment proposes actions that conserve important building features, enhances the historic character and maximizes the opportunities for visitation and interpretation,

The Recommended Ultimate Treatment includes the preservation of the exterior and interior, the restoration of key exterior features to their c. 1976 appearance, and the rehabilitation of certain features to more safely accommodate public visitation.

A 1976 restoration date was chosen because it was a pivotal year when the Fresnel lens was removed and replaced with two aero-beacons. Regardless of whether the restoration to that period includes the retention of those two lights or the return of the Fresnel lens, the remainder of the building would reflect the major modifications of historical importance and remove the more distracting and intrusive changes that occurred after that year.

This approach would have the following advantages:

- Preserves in place for interpretation, tangible evidence from a broad spectrum of the lighthouse's history.
 - Retains the distinctive black-and-white diamond-pattern paint scheme of the tower, which has been in place since 1873.
 - Interprets more fully an historical epoch by preserving the 1914 watch-level observation deck and reconstructing the 1914 watch-level board walls and second-floor interior doorway.
 - Potentially reinstalls the original Fresnel lens.
 - Retains the mid-twentieth century beacon equipment, batteries, and emergency generator of the first floor, evidence of an epoch of the lighthouse's history.
 - Removes modern additions (such as the steel entrance doorways, the cyclone fence room, and the steel square pipe and angle shoring) whose designs are incongruous with the historical architecture..
 - Addresses the deterioration of significant historic fabric before it progresses to the point of requiring replacement;
 - Eliminates the necessity for, and thus allows for the removal of, the modern steel square-pipe-and-angle shoring which distracts from the lighthouse's historical character and hinders access through interior spaces;
 - Corrects the causes of structural deterioration of the upper masonry
- and cast-iron lantern rather than applying yet another temporary repair;
- Improves safe passage through the interior spaces of the lighthouse by removing the 1989 steel from egress doorways and stairs, adding reinforcement to certain early character-defining elements (cast-iron stair treads) and adding visually unobtrusive elements (a second spiral-staircase handrail).
 - Improves historical interpretation by removing the modern configuration of wood entrance stairs and allow a more accurate reconstruction based on archaeological evidence.
 - Improves safe passage along the wood entrance stairs by incorporating handrail design and other potential modifications that are more consistent with code recommendations.
 - Enhances interpretation by facilitating visitation.
 - Constitutes the most cost-effective, long-term expenditure for treatment.
- This approach would have the following disadvantages:
- Potentially removes the two 1976 aero-beacons, in situ evidence of an epoch of the lighthouse's history and the current source of a powerful navigational light.
 - Removes the 1989 steel reinforcement, evidence of an epoch of the lighthouse's history.

- Removes the 1999 steel entrance doors, evidence of a minor epoch of the lighthouse's history.
- Constitutes the most expensive initial outlay of financial expenditure for treatment.

B. REQUIREMENTS FOR TREATMENT

The General Management Plan for the Cape Lookout National Seashore was prepared prior to the acquisition of the Cape Lookout Lighthouse. Therefore, the lighthouse is not addressed in the plan.

The park, in cooperation with a friends' group, has established a goal of conducting public tours of the lighthouse including access onto the observation deck. However, park administration closed the interior to public access in January 2008 due to safety concerns. The closing led to the preparation of this Historic Structure Report.

The National Park Service Cultural Resources Management Guideline (DO – 28) requires planning for the protection of cultural resources on park property.

In addition, Section 106 of the National Historic Preservation Act (NHPA) mandates that federal agencies, including the National Park Service, take into account the effects of their actions on properties listed or eligible for listing in the National Register of Historic Places and give the Advisory Council on Historic Preservation a reasonable opportunity to comment.

Treatment of the building and site are to be guided by *The Secretary of Interior's Standards for Historic Preservation Projects*, the Americans with Disability Act, and the International Building Code. Threats to public life, safety and welfare are to be addressed; however, because this is an historic building, alternatives to full

legislative and code compliance are recommended where compliance would needlessly compromise the integrity of the historic building. *Appendix B: Structural Assessment/ Carrying Capacity Analysis* and *Appendix C: Code Compliance & Recommendations* of this report provide analytical data as supplemental information.

C. ALTERNATIVES FOR TREATMENT

In addition to the Recommended Ultimate Treatment discussed in Section I.A above, three alternative treatments are discussed below.

Alternative #1: Restore the exterior and interior of the lighthouse to their 1867 appearance and rehabilitate certain features to more safely accommodate public visitation.

This approach has the following advantages:

- Returns the building to its earliest design configuration and paint scheme of red limewash-coated masonry and black-painted lantern.
- Potentially reinstalls the original Fresnel lens.
- Focuses interpretation to a period that has few remaining lighthouses.
- Addresses the deterioration of significant historic fabric before it progresses to the point of requiring replacement.
- Eliminates the necessity for, and thus allows for the removal of, the modern steel square pipe and angle shoring which detracts from the lighthouse's historical character and hinders access through interior spaces.
- Corrects the causes of structural deterioration of the upper masonry and cast iron lantern rather than applying yet another temporary repair.

- Improves the safe passage through the interior spaces of the lighthouse by adding reinforcement to some early character-defining elements (cast-iron stair treads) and adding visually unobtrusive elements (a second spiral staircase handrail).
- Enhances interpretation by facilitating visitation.
- Constitutes a long-term efficiency of expenditures.

This approach has the following disadvantages:

- Replaces the well-known black-and-white diamond-pattern paint scheme of the masonry with a monochromatic red color.
- Removes the 1914 watch-level observation deck, which has historical significance.
- Removes the remaining 1914 watch-level board wall and door surround, which have historical significance.
- Removes the 1914 interior door surround at second-floor level, which has historical significance.
- Loses the opportunity to interpret the physical building fabric from 1914 that evidences the evolution of lighthouse service.
- Removes the mid-twentieth century beacon equipment, batteries, and emergency generator of the first

- floor, evidence of an epoch of the lighthouse's history.
- Removes the two 1976 aero-beacons, evidence of an epoch of the lighthouse's history and the current source of a powerful navigational light.
 - Removes the 1989 steel reinforcement, evidence of an epoch of the lighthouse's history.
 - Removes the 1999 steel entrance doors, evidence of an epoch of the lighthouse's history.

Alternative #2: Restore the exterior and interior of the lighthouse to their 1914 appearance and rehabilitates certain features to more safely accommodate public visitation.

This approach has the following advantages:

- Allows the most accurate design representation of an historical epoch by preserving the 1914 watch-level observation deck and reconstructing its air lock, the watch-level board wall air lock at seventh floor, and second-floor interior doorway.
- Retains the distinctive black-and-white diamond-pattern paint scheme of the tower, which has been in place since 1873.
- Potentially reinstalls the original Fresnel lens.
- Addresses the deterioration of significant historic fabric before it progresses to the point of requiring replacement.

- Eliminates the necessity for, and thus allows for the removal of, the modern steel square pipe and angle shoring which detracts from the lighthouse's historical character and hinders access through interior spaces;
- Corrects the causes of the structural deterioration of the upper masonry and cast iron lantern rather than applying yet another temporary repair;
- Improves the safe passage through the interior spaces of the lighthouse by adding reinforcement to certain early character-defining elements (cast-iron stair treads) and adding visually unobtrusive elements (a second spiral staircase handrail);
- Enhances interpretation by facilitating visitation.
- Constitutes a long-term efficiency of expenditures.

This approach also has the following disadvantages:

- Hampers visitor circulation along the observation deck with the reconstructed air lock.
- Removes the mid-twentieth century beacon equipment, batteries, and emergency generator of the first floor, evidence of an epoch of the lighthouse's history.
- Removes the two 1976 aero-beacons, evidence of an epoch of the lighthouse's history and the current source of a powerful navigational light.

- Removes the 1989 steel reinforcement, evidence of an epoch of the lighthouse's history.
- Removes the 1999 steel entrance doors, evidence of an epoch of the lighthouse's history.

Alternative #3: Preserve the exterior and interior of the lighthouse in its current appearance and rehabilitate the interior stairways with added reinforcement and handrails.

This approach has the following advantages:

- Preserves all building fabric, thus most comprehensively representing the various epochs of evolution with tangible evidence.
- Retains the mid-twentieth century beacon equipment, batteries, and emergency generator of the first floor, evidence of an epoch of the lighthouse's history.
- Retains the two 1976 aero-beacons, evidence of an epoch of the lighthouse's history and the current source of a powerful navigational light.
- Retains the 1989 steel reinforcement, evidence of an epoch of the lighthouse's history.
- Retains the 1999 steel entrance doors, evidence of an epoch of the lighthouse's history.
- Provides the least expensive treatment option, at least initially.

This approach also has the following disadvantages:

- Retains modern design elements that are incongruous with the historical character of the lighthouse, thus detracting from historical interpretation;
- Retains modern reinforcement that restricts safe passage through the historical spaces.
- Does not address the deterioration of the iron elements and associated deterioration of the masonry frustum.
- Diminishes the opportunities for the public to experience the lighthouse by hampering visitation to the lighthouse interior.
- Increases the cost of eventual repairs to the cast iron and masonry.

D. RECOMMENDATIONS

The Recommended Ultimate Treatment for the Cape Lookout Lighthouse includes the preservation of the exterior and interior, the restoration of key exterior features to their c. 1976 appearance, and the rehabilitation of certain features to more safely accommodate public visitation.

The 1976 restoration date is recommended because it coincides with the removal of the original Fresnel lens and replacement with the current two aero-beacons; the date leaves the possibility of the return of the Fresnel lens. This time frame also postdates the removal of the observation deck air lock, which blocked circulation. Further, this time frame predates insensitive modifications such as the installation of the modern steel doors, the awkward modern entrance steps, and the wire mesh room at second-floor level.

Actions to Achieve Recommended Ultimate Treatment:

To achieve the Recommended Ultimate Treatment, the following actions should be taken:

- Dismantle, thoroughly clean, repair and repaint the deteriorated iron elements of the lantern.
- Dismantle, clean, make operable where appropriate and repaint the brass elements of the lantern.
- Replace the damaged glass and reglaze all glass of the lantern;
- Repair and re-secure damaged copper sheets of the lantern roof.
- Repair and re-secure damaged copper sheets of the lantern ceiling.
- Install new isolation pads between iron and copper and copper-based lantern elements.
- Clean, repair, and make operable the lantern ventilator.
- Replace the lantern's deteriorated cast-iron plate connecting to the top of the masonry wall with a stainless steel plate.
- Replace the deteriorated cast-iron tension ring at the top of the masonry with a tension ring of non-corrosive material.
- Remove the modern steel tube and angle reinforcement;
- Selectively remove damaged bricks and mortar from the top twenty feet of masonry fulcrum, and replace in-kind.
- Dismantle, clean, and repair or replace the cast-iron walk plates of the lantern gallery.
- Remove the severely deteriorated galvanized steel railing of the eighth floor observation deck and replace with a non-corrosive metal railing of same design.
- At the watch room ladder stairs to the lantern, cast new treads and

- replace the two damaged by the steel reinforcement. Restrict lantern-level access to staff and service personnel only.
- At the service-level ladder stairs, cast new treads and replace the two damaged by the steel reinforcement. Install a stair handrail for additional safety.
 - At service level, reconstruct missing section of the 1914-era enclosing board wall. Reconstruct walls and doorway of air lock as per physical evidence and original plans. Reinstall original doors and door hardware now in North Carolina Maritime Museum or construct and install replicas.
 - At the spiral staircase, retain the two treads modified in 1914 for the occulting mechanism, or replace shortened treads with the whole treads discovered in storage.
 - At the spiral staircase center column, add a handrail as another source of support for the visitor and to move the visitor toward the wider area of the tread.
 - At the spiral staircase, add reinforcement to each tread.
 - Remove the rubberized-paint coating from the exterior of the masonry. Clean mortar joints of failing mortar or incompatible pointing material. Repoint with mortar as per analysis. Repaint the historic black-and-white diamond pattern with a breathable coating.
 - Remove incompatible mortars from interior masonry and clean joints of failing mortar. Repoint with mortar as per analysis. Apply a breathable limewash coating to interior masonry.
 - Remove modern panel of second-floor landing and replace with early panel now in storage.
 - Remove two deteriorated, modern, steel, flat-panel entrance doors and replace with replicas of early wood doors according to physical evidence and photographic documentation.
 - Install replica door according to physical evidence at interior doorway of second-floor passageway.
 - Remove electrical lighting and associated equipment. Install interior and exterior lighting more appropriate for public visitation and maritime conditions.
 - Conduct archaeological investigations to establish pattern of construction of main entrance stairs. Remove existing main entrance stairs and install replacement stairs according to archaeological evidence. Make modification to design to bring handrails into compliance with International Building Code standards.
 - Install lightning protection system.
 - Install fire and intrusion detection systems.

**Recommended Limitations as per
International Building Code & Stair
Loading Capacity:**

- Limit total lighthouse occupancy to no greater than 25 persons at any one time.
- Limit the number of occupants at eighth floor Watch Room and Observation Deck combined to not more than 10 persons. Of these 10, two are to be NPS guides, one stationed in the room and the other on the deck.
- Limit the occupancy of the ship's ladder stairs between seventh and eighth floor levels to one at a time.
- Limit the occupancy of the seventh floor Service Room to not more than 3.
- Limit the number of occupants to 6 at each intermediate landing (levels 3 through 6) as per engineering analysis and IBC.
- Limit the number of persons per spiral stair tread to one, except for passing.
- At a minimum, station a third NPS guide at the base of the spiral stairs.
- Conform to IBC in the design and construction of the handrail added to the seventh floor ship's ladder stairs and the second handrail added to the spiral stairs.
- Construct with solid hardwood only the replica wood features (first and second floor entrance doorways, the second floor interior door, and seventh floor board walls and doors.)

Other Recommended Actions:

- Strategically place signage to remind occupants of the above restrictions.
- Allow visitors to make observation from window locations that are easily accessible.
- In addition to stationing NPS guides (NPS staff and/or volunteers) at the base of the spiral stairs and at the watch room/observation deck, station additional guides whenever possible along the stairs between those two points to monitor compliance and lend assistance as needed.
- Prior to entering the lighthouse, provide potential visitors with advance information describing the varying difficulty of ascending the lighthouse stairs and passageways.
- Prior to entering the lighthouse, provide potential visitors with physical mockups of the ladder-to-landing floor opening at the watch level and the ship's door hatch to the observation deck.
- Prepare an emergency plan for staff and volunteers, and establish stations for medical assistance along the visitation route.

APPENDIX A

Documentation Drawings

APPENDIX B

Structural Assessment/Carrying Capacity Analysis



STRUCTURAL ASSESSMENT OF CAPE LOOKOUT LIGHTHOUSE

The structural analysis of the stair treads and other structural elements of the lighthouse involved assumptions based on field observations and judgment of existing conditions. The following categories were developed and used in the computer model of the structure to define each component of the structural system for the purpose of analysis:

Excellent: Modeled as shown on original drawings (no evident loss of material/strength)

Good: Modeled with a 10 percent reduction of material due to deterioration, delamination, etc.

Fair: Modeled with a 25 percent reduction of material due to deterioration, delamination, etc.

Poor: Features in this category must be replaced, so models of existing conditions were not developed

Using *Visual Analysis*, computer models were built for each of the following to determine applicable capacities: a typical stair tread and a typical landing. Models were built and analyses were performed for both the current and the originally designed condition, for compliance with current building codes. All handrails were also reviewed for compliance with current building codes.

Live loads used in the analysis were based on Table 1607.1 of the 2006 International Building Code (IBC) with North Carolina Amendments. From the IBC, the minimum uniformly distributed live loads for stairs is 100 psf, so a 100 psf uniform live load and a 300 lb point load in the center of the stair, and two 250 lb point loads were used independently in the analysis of the stairs.

Wind loads for the Outer Banks from ASCE 7-05 and IBC Chapter 16, Figure 1609 were used to apply lateral loads on the upper levels of the lighthouse. An analysis of the current bracing configuration installed in 1988 determined that this bracing is adequate to resist all applied wind loadings. All models were checked for compliance with the 2006 International Building Code based on flexure, shear, and deflection criteria.

Since cast iron is not a product that is used as a structural material today, stress values had to be interpreted from various texts. *Structural Renovation of Buildings* (Newman) gives the typical maximum allowable bending stress for cast iron as 3 ksi with a safety factor of 13.33 and allowable bending stress of 12 ksi for wrought iron based on a safety factor of 4.17. The allowable bending stress of wrought iron matches the value given in *Iron and Steel Beams 1873 to 1952* (AISC). Based on the average modulus of rupture value of 40 ksi, the allowable bending stress was obtained by dividing the modulus of rupture by a safety factor, exactly like the method described in *Structural Analysis of Historic Buildings* (Rabun). The safety factor used for cast iron is substantially higher than that used for wrought iron. Cast iron is a brittle material, exhibiting little or no yielding before failure, and is weak and unpredictable in tension and

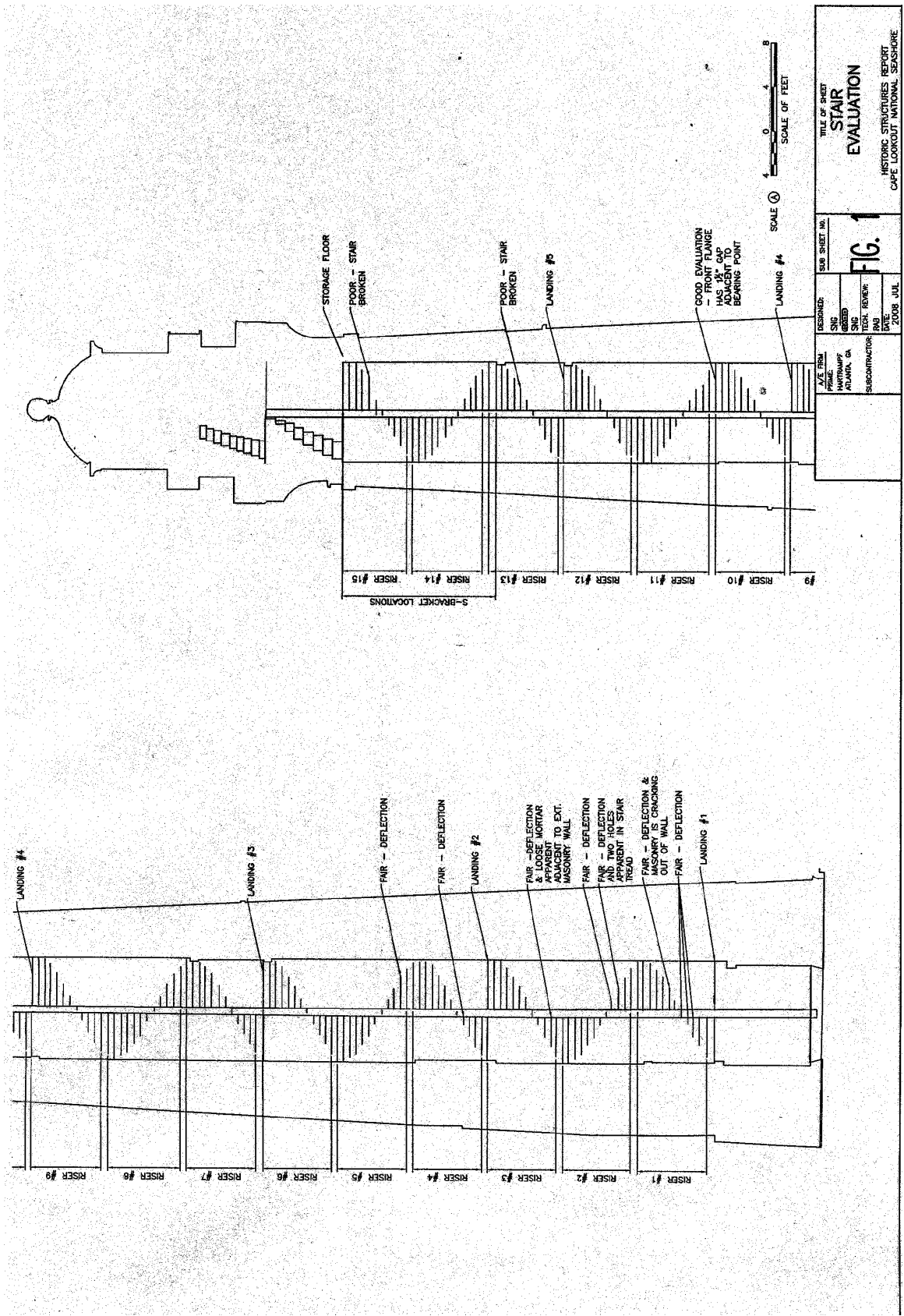

SCALE 1/8" = 1'-0"
SCALE OF FEET

FIG. 1 HISTORIC STRUCTURES REPORT CAPE LOOKOUT NATIONAL SEASHORE	
TITLE OF SHEET STAIR EVALUATION	SUBSHEET NO. 1
DESIGNER SNG CHECKED SNG DATE 2008 JUL	REVIEWER RAJ DATE 2008 JUL
A/E/FIRM HARTRAMP ATLANTA, GA	SUBCONTRACTOR



bending. Therefore, a higher safety factor must be used to account for that unpredictability and for the variability of different castings.

When analyzing an existing structure that has been standing for over 130 years, a lower factor of safety may be used than when designing a new structure. With a new structure, there is more uncertainty about how the structure and material will behave. An existing structure has been subjected to various loads throughout its life and, if it is still standing with no signs of distress, it is obvious that it can support those loads. Because structural capacity may be more accurately assessed for existing structures based on the current conditions, a smaller factor of safety than for a new structure may be used.

Because of the brittleness of cast iron, fatigue stress, caused by cyclic loading is a major concern. Three main factors affect fatigue performance of a structural component: material, loading (stress), and environment. The structural properties of a component, such as its metallurgical and mechanical properties and any discontinuities in the material, have a major effect on how much fatigue it can withstand. External environmental factors, such as temperature, also have an impact on a structure's fatigue life. According to *Fracture & Fatigue Control in Structures*, "the primary factor that affects the fatigue behavior of structural components is the fluctuation in the localized stress," that is, the number of repeated cycles of loadings to which a component is subjected. Once fatigue cracks develop, they will propagate rapidly as the magnitude of loading cycles increases and will ultimately lead to failure.

Stair System: The stair system was analyzed in multiple parts: in the lower portion of the lighthouse all of the spiral stair treads are independent of one another, and in the two ship ladders in the upper portion of the lighthouse all of the treads are inter-connected with a bracket system. The bracket system causes all the stairs to be stressed when loading is applied to a single stair, and therefore causing additional stress to the system. All of the treads appear to be cast iron and the brackets connecting the upper stairs appear to be painted mild steel. Analyses were performed on the individual stair treads for each connection type.

The majority of the spiral stair treads are in good condition, though some are in fair or poor condition. The source of concern for the fair or poorly evaluated stairs was primarily deflection criteria. Engineering of the stair system allows each of the stairs to act independently, but also allows for different deterioration to have occurred at each individual connection. It was observed that some of the mortar which helps provide the connection at the masonry wall has deteriorated and fallen away over time (see Figure 2), and may therefore cause treads to deflect more readily. Also, due to imperfections that may occur during casting and connections, the pin connections at the interior column could allow additional deflection (see Figure 3). Additionally some of the stairs may have received additional traffic or impact over time from unknown sources and therefore would show increased deflection at the time of analysis. (See Figure 1 for noteworthy stairs which were evaluated as fair or poor during the May 2008 structural evaluation.)



Figure 2 – Stair Connection at Exterior Masonry Wall



Figure 3 – Pin Connection at Interior Support Column

Analyses of a single tread were based on a 300-pound person stepping on the middle of a tread, and two 250-pound people stepping near the stair tread support points (including impact) per the IBC. By placing the loading in the center of the stair, the stress is maximized. Visitors climbing the lighthouse will most likely traverse up the stairs at a point closer to the handrail, and therefore additional loading may be applied if the loadings occur closer to the support points. As originally designed, a maximum stress of 8.2 ksi and a maximum deflection of 0.726 inch were produced. Existing treads in good condition produced a stress of 10.2 ksi and deflection of 1.0 inch, and existing treads in fair condition produced a maximum stress of 14.5 ksi and a deflection of 1.71 inch. The stress results for two 250-pound people traversing up the tower at opposite ends of the stair provided the controlling criteria.

With the stress results for two 250-pound people the safety factors are 3.9 for the treads in good condition and 2.75 for the ones in fair condition. Those safety factors are much lower than the recommended safety factor of 13.3 for new cast iron. Because of the variability of the different castings of the treads and the unpredictability of cast iron, the small safety factor exceeds the “comfort zone” of safety for cast iron and the possibility exists of failure of the stair treads when subjected repeatedly to the load of a 300-pound person.



However, the likelihood of a two 250-pound people walking up and down the lighthouse stair system simultaneously slim, so the treads were also analyzed for a more realistic condition, one 250-pound person stepping on the tread (including impact). As originally designed, the maximum stress of the analysis was 7.0 ksi. Existing treads in good condition produced a stress of 8.63 ksi, and existing treads in fair condition produced a stress of 12.2 ksi.

The stress results for a 250-pound person show safety factors of 4.6 for the treads in good condition and 3.3 for the ones in fair condition. Those safety factors are much smaller than the recommended safety factor of 13.3 for new cast iron. Because of the variability of the different castings of the treads and the unpredictability of cast iron, the low safety factor exceeds the safety “comfort zone” of cast iron, and the possibility of failure of the stair treads exists when repeatedly subjected to the load of a 250-pound person stepping on the tread. However, the stair treads have withstood the load of personnel using the stairs in the structure for over 150 years and are still in mostly fair to good condition. From the physical evidence of the existing treads, the treads in good condition should be able to support the loading of a 250-pound person stepping on a single stair tread. However, this does not account for the additional stress that will be caused by fatigue.

Over the years, the lighthouse has been accessed by a few people for maintenance purposes and has not been subjected to excessive loading. The two light keepers, working in shifts, walked up and down the lighthouse stairs every day for nearly 90 years until it was converted to an electrical light in 1933. Thereafter, fatigue loading cycles were less frequent until 1933, when the Cape Lookout became an unmanned light and such loading cycles ceased except for occasional maintenance activities. Typically when analyzing fatigue, loading cycles are taken for a 25-year period. Based on the history of its use, for four cycles per day over the first 25-year period, the stair treads and landings were subjected to 36,500 loading cycles. A National Park Service volunteer has estimated that 100,000 visitors per year will want to climb the lighthouse if it is open to the public, based on surveys of use for other lighthouses in the area. For the next 25-year period the number of loading cycles resulting from this number of visitors would be approximately 2,500,000. Based on the allowable stress range for fatigue at each loading condition, if the lighthouse were to be opened to the public at the number estimated, the increase in loading cycles would decrease the allowable stress of the structural component, specifically the stair treads and landings, by 60 percent over that 25-year period.

If the lighthouse were to be open for public access, the number of loading cycles would increase significantly from its past use. Little to no cracking is currently present on the stairs examined, but with increased traffic through the lighthouse fatigue cracking could propagate quickly if not addressed. The presence of cracking fatigue is a factor in the safety of the stair treads. Since the number of loading cycles will be increased more than 150 times its previous loading cycles, the fatigue stress on the stair treads will be increased by 60 percent from its current state. For a tread in good condition, using the 250-pound load, the stress would increase from 8.63 ksi to 13.81 ksi. The fatigue stress of 13.81 ksi exceeds the stress of 12.2 ksi determined for treads in fair condition. The number of loading cycles can be altered so that the fatigue stress on these treads is less than 12.2 ksi. The rationalization is that the existing treads have supported the load of a man for over 130 years and most are in good condition; therefore, as long as stresses are lower



lower than 12.2 ksi, the treads should be adequate. If the number of loading cycles on the stair treads is increased by only 25 times the previous condition, the fatigue stress will be increased by only 40 percent from the current state. A 40-percent increase in fatigue stress would result in a stress of 12.1 ksi for the treads in good condition, which is lower than the stress of 12.2 on the treads in fair condition for a 250-pound load. Based on the rationalization mentioned above, the stair treads in good condition should be able to support a 250-pound person if the magnitude of loading cycles does not exceed 50 cycles per day (25 people walking up and down) for a 25-year period. If the National Park Service wishes to allow more than 25 people per day into the lighthouse, the stair treads would have to be assessed again in several years. For instance, if 68 people were allowed into the lighthouse per day, the stair treads would have to assess again in ten years for fatigue. That number can be increased to 95 people per day for assessment in seven years. In any case, if the light tower is opened for public visitation, the National Park Service should implement a program of regular inspections of all stair treads for cracks.

Landings: Analyses were also performed on the landing plates and beams, which are typical across most levels, as originally designed and in its existing condition. As noted in the original construction drawings, the landing plates are formed with bracing ribs integral to the plates. The integral bracing prevents most deflections out of plane and adds strength to the landing plates. Some out of plane deflection is visible at some landings and this concern is addressed in the recommendations section below.

One landing differs in construction from the remainder of the other landings. The third floor landing is of wood construction with wood support beams (see Figure 4). Analyses were also performed on this landing to determine if it may provide adequate capacities to support the traffic which will occur. In addition, since this is the first landing that visitors will reach it is more likely that it will receive the most traffic and impact. Interest was expressed by both the park service staff, and the architect to preserve this landing during the May 2008 site visit. In an earlier report “Engineering Study of Cape Lookout Lighthouse” issued on May 12, 2005, issues concerning the fire resistivity of this landing were expressed. Recommendations for these concerns may be found in the recommendations section below. The flexural and shear capacities used in analysis were that of visually graded sawn Southern Pine No. 2. It is known that the lumber present during the construction of the lighthouse had a greater available capacity, but the decrease in allowable values ensure that the actual landing capacities are conservative.

Analysis has shown that the presence of the bracing ribs (at the steel landings) increases the allowable stress by 25 percent to 3.75 ksi for the landing plates. Using the minimum code recommended live load of 100 psf, the maximum stress of the landing plates as originally designed was calculated to be 5.4 ksi, giving a safety factor of 9.3 based on the additional 25 percent of allowable stress. Although that value is lower than the recommended safety factor for cast iron, it is still a comfortable safety factor since the landing plate showed no apparent signs of cracks. The maximum calculated deflection of 0.42 inch exceeds the allowable deflection of 0.23 inch. In its existing condition, an analysis of the steel plate landing produced stress and deflection results of 6.5 ksi and 0.56 inch. With the additional 25 percent allowable stress, the safety factor for the existing landing plate is 7.7, much lower than the recommended safety factor of 13.3 and exceeding the “comfort zone” for safety. Since analysis of the landing plate produces

results that exceed the safety “comfort zone,” there is a possibility of failure if the landing is fully loaded to the maximum code-mandated load of 100 psf; 16 people weighing 250 pounds per person would have to stand on the landing. It would be physically impossible for 16 people to stand on the landing simultaneously. A more realistic assumption would be 6 people on the landing at the same time (one person per 7 square feet), reducing the load to approximately 40 psf and the stress to 3.2 ksi. The resulting stress would be within the recommended range for cast iron.



Figure 4 – Wood Landing

Bracing: Bracing elements were added in 1988 in order to remove lateral forces from the existing masonry, and support the upper lantern level. Cracking has propagated through the upper portion of the lighthouse, and therefore the original masonry in its current damaged state does not provide sufficient capacities to resist hurricane force without the assistance of the additional bracing. The presence of the existing bracing inhibits traffic passage in the upper portion of the lighthouse and, therefore, interest was expressed to remove some elements in order to facilitate the passage of visitors.

During the field evaluation, all of the steel at this level was determined to be in good condition, though some surface rust was present, none of which appears to have penetrated the steel fully. Therefore, it is believed that the steel bracing as described in the recommendation section below may be removed with the possibility that additional strengthening may have to occur at the beam to column joints for lateral stability.

The presence of the frame is still required, but small modifications may be made to allow visitor traffic to proceed safely. Interest has been expressed to restore the lighthouse to the original condition by removing all instances of the bracing, which was added during 1988. See the



recommendations section below for applicable revisions that must be made for such modifications to occur.

Watch Level Observation Deck: This exterior deck consists of a metal pan deck supported by a brick corbel, which projects from the lighthouse shaft. An inspection was performed on the exposed deck from the top and the bottom and it appears to be in good condition. The deck in this condition is adequate to support the passage of visitors on this level. Some surface rusting was exhibited on the bottom portion of the deck, but this should not affect the capacity of the deck, and therefore no additional bracing is required for this level.

The steel handrails at the observation level exhibit significant rusting and a vast majority of them have rusted through. Therefore, it is recommended to replace all posts and handrails to provide maximum safety and resist the code prescribed live lateral loadings.

Lantern Level Gallery: The structural elements were not analyzed for the lantern level. This level will be used for maintenance purposes of the light only. Currently it is not recommended that any visitor traffic proceed to this level.

Roof: A structural analysis was not performed on the roof. A visual inspection of the interior and exterior of the roof indicates a separation of the trim from the roof panel at the cornice bracket. A few of the bolts that connect the trim to the roof have deteriorated, enabling the trim to separate from the roof. From a structural perspective, because the span of the trim and roof panel (approximately 2'-3") and the forces on the roof are not great, risk of failure of the roof connection is not an immediate concern. However, the greatest risk is an abnormal wind condition that could dislodge the roof and do significant damage to this historic feature that is otherwise sound. Repair to the trim involves removing the paint on the trim to check for any deterioration. If there is no deterioration of the trim, the missing and deteriorated bolts should be replaced with new stainless steel bolts and the trim reattached to the roof panel and cornice. Missing trim pieces should be replaced to match the original.

Recommendations - Structural

Stair System: Based upon the visual as well as computer analyses performed it is recommended that the altered stair treads be replaced that to support for minimum traffic of VIPs and park service staff (see Figure 1 for altered stair tread locations). It is our understanding that during the investigation additional stair treads were found in storage which appear to have been manufactured at the same time as the existing stair treads. Upon inspection of these treads to determine that no cracking is visible, these treads may be used to replace the altered treads. In addition, it is also recommended that the stair treads determined to be in fair condition as indicated in Figure 1, be stiffened through the use of a channel, with flanges protruding downward, or other stiffening element which runs under the length of the stair. If increased traffic of tourists is desired through the lighthouse, all of the improvements as indicated in the paragraph above should be performed, and all stair treads be stiffened (per the methodology described above) to prevent any fatigue cracking.



Currently one handrail exists along the perimeter masonry wall to the watch level. In order to ensure that tourist traffic may proceed in both directions in the safest manner possible it is recommended that an additional handrail be inserted along the center support column. The handrail should be offset from the column a minimum distance of six inches (6") to prevent impact on the smallest part of the stair and undue fatigue on the pin used to support the stair tread at the column.

Landings/Handrails: Currently the cast iron plate landings are deemed sufficient to support tourist traffic. The cast iron plates exhibit some surface rusting. This rusting does not provide concerns for structural stability, but aesthetically the surface rust should be removed and the plates should be repainted. Some differential plate movement has occurred at some landings. This provides a tripping hazard, and angles should be added on the underside of the plates at the rib locations for a plate to plate connection in order pull together the plates and to prevent any additional movement. One floor plate did exhibit cracking during the May 2008 evaluation. Due to this isolated condition, this floor plate should be supported along the cracked location using a similar method as described above for the stair treads.

The single wood landing as previously discussed is sufficient to provide support for traffic. As previously mentioned the fire-resistivity was expressed as a concern in the "Engineering Study of Cape Lookout Lighthouse". The fire resistivity could be increased through the use of an intumescent paint and its potential application merits further consideration.

The handrails which currently exist along the perimeter masonry wall do not meet the size standards of current codes. These handrails however, allow enough stability to adequately support lighthouse traffic. There is one support point, which has been separated from the masonry, which should be replaced prior to the lighthouse being occupied for anything more than maintenance purposes.

Storage Level: The storage level, which is currently used as the transition point between the main stairway and the watch level, is also the lowest level of the bracing which was used as the stabilization technique in the 1988 drawings. The introduction of the X-bracing caused some access safety issues. It has been determined that some elements may be removed or modified in order to facilitate visitor traffic. The brace which inhibits passage through the main door into the storage level may be removed, but the angle support, which also occurs at this location, must remain in order to support the bracing members above. This angle may be trimmed in order to increase clearances but it should not be removed.

Bracing also occurs on the opposite wall face to the bracing described above. In order to insert this bracing element, the separation wall from the storage level to the main staircase opening had to be partially removed (see Figure 5). This opening and resulting instability of the wall could endanger tourists on this level. The bracing should be removed at this location and the wall should be restored so that it would fully block passage through this area. This separation wall must also be stiffened at mid-height with a horizontal brace supported off of the masonry wall and the center column in order to ensure that this wall provides enough rigidity in order to support a lateral force (visitors leaning against the wall) against this partition.

The original cast iron ship ladder which allows passage of traffic from the storage to the watch level poses some challenges. The tread height is somewhat steep, the ladder consists of four partial treads due to the insertion of the 1988 adjacent bracing, and the maximum width of the stairs is narrow at 26". Passage is not ideal. Given its importance as an original character-defining element, other limitations of the path of travel, and the potential for full restoration of the lighthouse, it is recommended that if the ladder be retained in place and a temporary railing be added or other remedial action be taken to ensure safe passage.

Watch Level Recommendations: Overall, the watch level was determined to be in good condition. Internal braces, similar to what was previously discussed at the storage level, exist around the perimeter of the lighthouse. The brace located directly in front of the passageway to the exterior watch level may be removed to facilitate easier passage. The boat hatch type opening to the exterior watch does not provide a large amount of room, but removal of the adjacent masonry and lintels would compromise the structural stability of the lighthouse and is not recommended.



Figure 5 – Bracing Interrupting Partition Wall at Storage Area

The exterior watch level observation deck appears to also be in overall good condition. The decking consists of a metal pan with concrete fill, and some surface rusting is exhibited on the bottom; the deck has only a small cantilever, but is overwhelmingly supported by a brick corbel. The surface rusting should be removed during repair work, and the underside of the deck should be repainted for aesthetics as well as to prevent additional rusting through this area. Wear to the top of the deck has also exposed some of the concrete deck reinforcement. In order to prevent any additional wear on this structural element the deck should be resurfaced with new concrete. As previously indicated in the gallery deck analysis section above, the handrails exhibit significant rusting and do not provide sufficient lateral support, and should be completely



replaced. In addition, it appears that the current handrails are not original to the lighthouse as there are other embedment points along the perimeter of the deck. These embedment points should be filled for aesthetic reasons as well as to prevent any tripping hazards which may occur.

Lantern Level Recommendations: The current overall lantern condition is currently evaluated as poor due to broken floor plates and rusted out support points. It is recommended that only maintenance traffic be allowed into this area due to the unsafe conditions. The ships ladder which allows passage from the watch level to the lantern level should be roped off and sufficient signage provided to indicate that traffic should not proceed up to this level. For visitor or minimum occupancy it is recommended that no traffic occur onto the outer deck and therefore at this point in time no improvements are deemed necessary.

Full Historic Rehabilitation: Rehabilitating the lighthouse to remove all of the bracing additions per the 1988 drawings would require significant maintenance efforts. According to the structural evaluation performed in May 2008, it is determined that the window mullions at the lantern level have little structural support capabilities. In order to remove all non-original bracing, the lantern level must be removed from the masonry base of the lighthouse for proper repair of mullions and floor plates.

In addition, the bracing from the lantern level through the storage level was added in order resist the applied lateral loadings from wind forces. The braces are not historically accurate or aesthetically pleasing, but in order to fully remove all of this bracing due to the cracking observed at these levels, the masonry must be fully removed and rebuilt from below where the current X-bracing brackets are embedded into the concrete to approximately twenty feet (20') of masonry. Upon design phasing inception, the lighthouse will be properly evaluated to determine that the masonry below the brackets is sufficient to support all lateral wind forces and allowing for all former bracing to be removed.

All previous recommendations of the stiffening of the stairs and landings are still required in order to ensure that fatigue cracking does not propagate from prolonged traffic up and down the lighthouse.

**** End of Report****

APPENDIX C

Code Compliance and Recommendations

CODE COMPLIANCE and RECOMMENDATIONS

INTERNATIONAL BUILDING CODE (IBC):

Chapter 10: Means of Egress

Section 1008 Doors, Gates and Turnstiles

- 1008.1.1 Size of Doors
 - “...clear width of not less than 32 inches.”
 - “...height of doors not less than 80 inches.”

Section 1009 Stairways and Handrails

- 1009.1 Stairway Width
 - “Stairways serving an occupant load of 50 or less shall have a width of not less than 36 inches.”
- 1009.3 Stair Treads and Risers
 - “...riser heights shall be 7 inches maximum...depth shall be 11 inches minimum”
- 1009.6 Vertical Rise
 - “A flight of stairs shall not have a vertical rise greater than 12 feet between floor levels or landings.”
- 1009.9 Spiral Stairs
 - “...permitted to be used as a component in the means of egress only within dwelling units or from a space not more than 250 square feet in area and serving not more than five occupants, or from galleries, catwalks and gridirons...”
 - “...shall have a 7.5 inch minimum clear tread depth at a point 12 inches from the narrow edge.”
 - “...riser height shall not be more than 9.5 inches.”
 - “...minimum stairway width shall be 26 inches.”
- 1009.11 Handrails
 - “Stairways shall have handrails on each side.”

Section 1012 Guards

- 1012.2 Height
 - “...shall form a protective barrier not less than 42 inches high....”
- 1012.3 Openings
 - “Open guards shall have balusters or ornamental patterns such that a 4-inch diameter sphere cannot pass through any opening up to a height of 34 inches.”

CONDITIONS:

Location:

1st Floor:

Conditions:

Round room of 10' - 6" diameter.

Floor-to-ceiling height 10' - 4"

No vertical connection;

Exit door of 31" width in original masonry opening of 3' - 8" x 7' - 7".

2nd - 6th Floors:

Handrail at perimeter masonry wall.

Vertical rise between landings is 24' - 0".

Cast-iron spiral staircase with wedge-shaped stair treads of 4' - 10" width.

- Tread depth of 4" at connection to column.
- Tread depth of 18" at perimeter masonry wall.
- Tread depth of 7½" occurs 14¾" from small tread end (at column).
- Only outer 2' - 6" of tread has a depth of 11" to 18".
- Rise between treads is 8".

Second floor exit door of 31" width in masonry opening of 3' - 5" x 7' - 7".

- Entrance passage has interior doorway for door of 32"+.

Second floor is a full-circle landing.

- Six, wedge-shaped, metal floor plates.
- Landing area comprised of 86 s.f.

Third thru sixth floor are intermediate level landings of half-circle size.

- Three landings are made of three cast-iron floor plates.
- One landing is made of wood deck boards on iron and wood frame.
- Each intermediate landing area has 43 s.f.

7th Floor

A floor-to-floor height of 8" - 0".

One 1914 doorway in board wall at landing.

- Missing door has 24" width.
- 1989 steel reinforcement reduces doorway width to 20".
- 1914 air lock with 24" wide doorway proposed for reconstruction.

Cast-iron, ship's ladder stair connects with Eighth Floor landing.

- No handrail.
- Rise between stair treads is 9".
- Stairs have a 2' - 0" width.
- Treads are boot-shaped with 6¾" to 9¾" tread depth.

8th Floor

A floor-to-floor height of 7' - 2".

Ship's hatch connects with outside Observation Deck;

- Hatch is 18" x 36" in 27½" x 57" original masonry opening.

Observation Deck circles Eighth Floor Watch Room.

- Deck has a depth of 4' - 2".
- Deck rail is 45" high with two rails and stanchions 34" o.c.

Cast-iron ship's ladder stairs connects to Ninth Floor Lantern.

- Stairs has no handrail; 9½" rise;

- Stairs have a width of 1'-9".
- Treads are boot-shaped with depth varying 3½" to 4½".

9th Floor

Glass in metal frame creates sixteen-sided Lantern.

Metal-and-glass door connects with outside Gallery.

- Metal-and-glass door has width of 2' – 0".

Lantern Gallery encircles Lantern.

- Gallery depth is 2' – 1".
- Gallery deck has top rail of 38" height and no second rail.

ASSESSMENT & RECOMMENDATIONS:

At the main portal to the lighthouse (second floor entrance) the current modern door is less wide at 31 inches than the 32 inches clear width that code requires. However, the historic doorway was partially infilled for the modern door. Restoring the doorway will remove the infill and thereby correct this too-narrow doorway. The wood stairs that lead to this entrance are modern. They are scheduled for repair.

The original cast-iron, spiral stairs extend from the second floor to the seventh floor landing. The IBC does not make reference specifically to a lighthouse for egress considerations; under "spiral stairs" as a means of egress, however, there is a general qualification that such a feature should serve no more than five occupants. This is an unrealistic limitation for the occupancy of a former work station now converted to a tourist destination, especially in light of the minimal amount of combustible materials and lack of potential incendiary sources, as well as the limited opportunity for other potentially sudden, unforeseen causes of disaster.

In calculating a more realistic number of occupants with a pragmatic procedure for visitation, it is the historically tight dimensions and awkward shapes of the building elements, rather than the inherent strengths of the building materials, that pose the greatest danger to safe usage. The wedge-shaped stair treads of the spiral stairs are especially problematic; they are difficult to navigate and the process, either climbing or descending, is slow and tedious. NPS prefers a tread depth of eleven to eighteen inches. On these wedge-shaped treads, this preferred depth range leaves just two and one-half feet of tread for use, or room for just one person per tread. However, if the seven and one-half inches of minimum tread, as the code recommends, is deemed acceptable at least occasionally, the width of usable tread becomes three feet and seven inches, which allows two people to pass. Limiting one person per tread, except for passing, is also desirable because it minimizes loading and thereby the wear to the treads. To accommodate the potential of two adults per stair tread, all the treads will need to be reinforced.

The stair landings at the intermediate levels (floors three through seven) are half the area (43 square feet) of floors two and eight. If the typical number of seven square feet per person is used, this limits the number of persons allowed at intermediate landings to six. Seven square feet per person, as used as a guide for other lighthouses, appears to be a comfortably safe number.

A bottleneck occurs at the seventh floor where an historic doorway is just twenty-four inches wide and is also intersected by modern steel reinforcement creating a smaller passage. Though it can be modified somewhat, part of this steel must remain in place or the tower masonry properly repaired. Until the steel is removed, the number of occupants at this level and above should be minimized.

At the eighth floor, the small access portal to the Observation Deck, the feature providing the grandest view, is even more physically restrictive. Accordingly, the number of persons allowed on the Observation Deck at one time should be limited and carefully monitored.

We recommend, for safety of egress, that at any given moment:

- No more than 25 total occupants are to be allowed in the lighthouse, the same total number allowed at the Bodie Island Lighthouse.
- Only NPS staff and service personnel are to use the ship's ladder to the Ninth Floor Lantern, to be at the Lantern level, or on the Lantern Gallery.
- No more than 10 occupants are to be in the Watch Room (eighth floor landing) and on the adjoining Observation Deck combined. Two of these 10 occupants are to be NPS guides, one stationed on the Observation Deck and the other inside the Watch Room as is typical for the annual Lighthouse Climb SOP.
- No more than one person at a time is to be allowed on the ship's ladder stairs between the eighth and seventh floor landings.
- No more than 3 occupants may be in the Service Room (seventh floor landing.)
- No more than 6 persons are to be on any intermediate landing (Levels 3 through 6.)
- No more than 1 person per spiral stair tread is permitted, except for passing.
- At a minimum, a third NPS guide is to be stationed at the base of the spiral staircase.

In addition, we recommend:

- The repairs to the existing and/or reconstruction of an earlier exterior wood stairs to the second floor entrance are to incorporate elements that bring the handrail into compliance with code.
- The replacement doors for the first floor entrance, second floor entrance, second floor interior intermediate door and two doors of seventh floor are to be made of solid hardwood.
- The added handrails of the spiral stairs and the seventh floor ship's ladder stairs are to conform to life and safety code standards.

APPENDIX D
Materials Analysis

Cape Lookout Lighthouse

Materials Analysis

Cape Lookout National Seashore, North Carolina



February 2009



BUILDING CONSERVATION ASSOCIATES INC

Cape Lookout Lighthouse

Materials Analysis

Cape Lookout National Seashore, North Carolina

Prepared For

Joseph K. Oppermaun - Architect P.A.
Winston-Salem, North Carolina

Prepared By

Building Conservation Associates, Inc.
329 Race Street
Philadelphia, Pennsylvania 19106

CONTENTS

1.0 INTRODUCTION	1
2.0 BACKGROUND INFORMATION	2
3.0 METHODOLOGY	4
3.1 Finishes Analysis	4
3.2 Mortar Analysis	6
3.3 Brick Analysis	6
4.0 SUMMARY OF FINDINGS.....	8
4.1 Exterior Finishes Analysis	8
4.2 Interior Finishes Analysis.....	14
4.3 Mortar Analysis.....	21
4.4 Brick Analysis	24
5.0 CONCLUSIONS & RECOMMENDATIONS	26
5.1 Finishes	26
5.2 Masonry.....	31

APPENDICES

Appendix A: Key to Sample Locations

Appendix B: Sample Stratigraphies and Photomicrographs

Appendix C: Mortar Analysis Report (Testwell, Inc. 2008)

Appendix D: Brick Analysis Report (CTL Group 2008)

1.0 INTRODUCTION

At the request of Joseph K. Oppermann Architect, P.A., Building Conservation Associates, Inc. (BCA) prepared an analysis of select building materials of the Cape Lookout Lighthouse. The lighthouse is located in Cape Lookout National Seashore in the Outer Banks of North Carolina. The materials investigated as part of this study include brick, mortar and paint finishes. The primary goal of the materials analysis is to document the building's original mortar and paint finishes, as well as the physical properties of the original brick, for inclusion in a Historic Structure Report (HSR). A secondary goal is to provide recommendations for future restoration work based on the findings of the analysis.

The report summarizes the findings of both the masonry analysis and the finishes study. Following the introductory information regarding the site and study methodology, the report discusses the findings of the research and then makes recommendations for appropriate restoration mortar mixes and paint colors. All mounted cross-sections have been labeled and permanently housed and will be archived at BCA's Philadelphia office unless otherwise requested by the client. The extracted aggregate portions of the analyzed mortars will be submitted with this report for reference during restoration.

All work required for the execution of this study was performed by Dorothy S. Krotzer, BCA Regional Director, with assistance from Testwell, Inc. and CTL Group for completion of the laboratory portion of the masonry analysis. Mortar, brick and paint samples were taken from the site in September and October 2008 and laboratory analysis was performed in October and November 2008.

2.0 BACKGROUND INFORMATION

The current Cape Lookout Lighthouse was built in 1858-59 to replace an undersized, wooden lighthouse with an interior masonry stair tower that had been built in 1812.¹ The existing lighthouse is constructed solely of brick with an internal cast iron stair that extends up nine levels and approximately 150-feet to a metal and glass lantern that sits atop the masonry structure. The design of the lighthouse is based on a prototype developed by a member of the Corps of Engineers, William Henry Chase Whiting.² Interior spaces include entry at the second floor level, a Service Room at the seventh floor level, an Observation Deck and Watch Room at the eighth floor level and the Lantern at the ninth floor level. (Figures 1 and 2)

The lighthouse exists today in relatively good condition and fairly intact, with much of its original 1859 fabric still extant. However, there have been some alterations to the building, the most significant of which include: repairs to interior steps and landings that were damaged during the Civil War; an exterior re-painting campaign in 1873; widening of the Watch Room observation deck and installation of interior wood partition walls in 1914; and extensive window and door replacement in 1996 following damage from Hurricane Fran.³ The 1873 re-painting campaign, which was executed at the direction of the U.S. Light House Board and is well documented in period descriptions of the building, is particularly important because it marks a significant shift from the lighthouse's original appearance to its existing, iconic appearance. Its existing black and white checkered exterior dates from this 1873 re-painting campaign and is not original.⁴ This shift in the lighthouse's exterior appearance will be discussed in more detail later in the report.

The lighthouse passed from the hands of the U. S. Lighthouse Service to the U.S. Coast Guard in 1939 and subsequently to the National Park Service in 1984. The lighthouse was placed on the National Register of Historic Places in 1972.⁵

¹ Oppermann, Joseph K. Architect P.A. *Cape Lookout Lighthouse Historic Structure Report 75% Draft*. August 2008. Page I.B.3

² Ibid, I.B.4

³ Ibid, I.B.32.

⁴ Ibid, I. B.18

⁵ Ibid, I.B.23-25.



Figure 1. Cape Lookout Lighthouse, September 2008. Photograph by author.



Figure 2. Cape Lookout Lighthouse, September 2008. This photograph shows typical interior features, including the exposed brick walls and cast iron spiral stair. Photograph by author.

3.0 METHODOLOGY

Prior to the site visit and removal of samples, information related to the history of Cape Lookout Lighthouse provided by Joseph K. Oppermann was reviewed. A draft of the HSR, including historic images and information on the construction chronology, were studied in order to gain a general understanding of the history of the building and any information related to its paint finishes and masonry construction.

Once the relevant historical documentation was reviewed, a site visit was made and the building was physically examined for areas from which representative samples of brick, mortar and paint finishes could be removed. Once these intact areas were identified, samples were removed. In addition, various salvaged wood elements currently in storage at the North Carolina Maritime Museum in Beaufort, North Carolina were examined and sampled as part of the paint analysis portion of the project. These salvaged elements are of particular significance because many of the historic wood components of the lighthouse have been removed. These salvaged pieces represent the only surviving examples of historic (presumably original) exterior wooden elements such as window sash.

Bricks were removed using a combination of hand tools, an angle grinder and a hammer drill. Mortar samples were removed using a small masonry chisel or five-in-one tool and a hammer. Paint samples were removed using a scalpel. A total of 2 mortar samples, 5 whole brick units and 34 finish samples were removed from the building and taken back to the laboratory for analysis. See *Appendix A* for a list of all sample locations. (*Figures 3 and 4*)

3.1 Finishes Analysis

All finish samples were initially examined in reflected light using a Nikon high-resolution stereomicroscope SMZ-1500 with variable magnification (16x-160x) to identify which samples would be embedded and sectioned for analysis. The selected samples were then mounted in a commercial polyester/methacrylate resin polymerized with a methyl ethyl ketone peroxide catalyst (Bioplast®). Embedded samples were sectioned on a Leco® VC-50 micro-saw for microscopic examination. The sectioned samples were dry-polished using a series of fine Micromesh® polishing clothes ranging from 6,000 to 12,000 grit. Sectioned samples were observed under a Nikon 50i compound microscope in both visible light filtered through a daylight correction filter and ultraviolet light. The ultraviolet light was generated by a mercury illumination system filtered through a violet filter cube (EF4 V-2A Ex400/40 Dm430 Bar 450). Photomicrographs of representative samples were taken using a 5 mega pixel Nikon DigiSight color digital camera system and are included in this report to illustrate specific observations.



Figure 3. Cape Lookout Lighthouse, September 2008. Location of well-preserved original mortar that was sampled for analysis. Photograph by author.



Figure 4. Cape Lookout Lighthouse, October 2008. Removal of a brick for laboratory testing. A total of five bricks were removed from the building. Photograph by author.

All paint samples were viewed in cross-section and their paint layering sequences, or stratigraphies, recorded. These stratigraphies are included in Appendix B. Once the stratigraphies of every sample were deciphered, significant paint layers were identified and raw samples were manipulated in order to expose these layers for color matching purposes. Once the target layers were exposed, they were subjected to a bleaching process in order to reverse any yellowing that may have occurred over time. It is well documented that linseed oil-based paints (especially pale-colored paints) darken and yellow over time if not exposed to sunlight. This even affects oil-based finishes that have been covered with subsequent paint layers. In order to diminish this yellowing of paint layers, they were exposed to a broad-spectrum fluorescent light source for approximately two weeks.

Following the bleaching process, the exposed layers were visually matched to two different color systems, the standardized Munsell color system and the commercial Benjamin Moore paint palette. All color matches are included in Section 5.1 of this report.

3.2 Mortar Analysis

Samples of brick mortar were removed from two locations: the exterior brickwork of the Watch Level (from an area of parging inside an air intake) and the interior brickwork of the Ground Level room. cursory visual examination of the mortar samples was performed by D. Krotzer and subsequent laboratory analysis was executed by John Walsh of Testwell Laboratories, Inc. in Ossining, New York. John Walsh specializes in the analysis and identification of historic mortar materials. Testwell's laboratory work included both petrographic examination and chemical analysis (acid dissolution, gravimetric analysis and atomic absorption spectroscopy) of each mortar. The goal of Testwell's analysis was to identify the binder and aggregate components of each mortar, as well as the original component ratio. Although Testwell's findings are discussed in Section 4.3 of this report, the full mortar analysis report has also been included in Appendix C. In addition, the extracted sand portion of each mortar sample has also been submitted with this report.

3.3 Brick Analysis

Five whole brick units were removed from the interior wall of the Ground Floor Level room at the rear of the lighthouse. The bricks were carefully removed by cutting out the original mortar joints surrounding the bricks in order to free them from the wall. This task proved to be challenging, as the mortar was quite hard and very well-bonded to the bricks on all sides. The irregularities in the composition of the brick also made them prone to spalling and cracking with even the slightest bit of pressure. Once the bricks were removed, modern replacement brick of approximately the same dimensions were installed in the voids created by the sampling procedure. They were installed in the original pattern, but using a soft lime based mortar to ensure reversibility.

The bricks were sent to CTL Group in Skokie, Illinois for physical testing in order to establish their overall physical attributes and compare them to modern standards. The bricks were subjected to water absorption and compressive strength testing in accordance with ASTM C-67. The results of all physical testing are discussed in Section 4.4 and CTL Group's report is included in Appendix D.

4.0 SUMMARY OF FINDINGS

4.1 Exterior Finishes Analysis

Examination of the exterior finishes of the lighthouse involved investigation of the painted brick masonry, woodwork and metalwork associated with the lantern and observation levels. Each of these architectural components is discussed below.

MASONRY

Analysis of paint samples indicates that the exterior brick masonry of the lighthouse contains two early campaigns of red limewash followed by four to six campaigns of black and white paint (always applied in a checkered pattern). The red limewash is also visible under the existing exterior paint coatings, on the surface of both the brick and mortar, in numerous locations. Archival research, performed by Joseph K. Oppermann Architect, P.A. as part of the HSR, revealed that the lighthouse was historically red in color. An 1859 *Notice to Mariners* states that: “The color of the tower is red.”⁶ Until now, the source of the red color was unknown. The color could have been achieved through the application of an oil paint or the description could have simply referred to the color of the brick masonry construction. The current research, however, provides proof that the first finish applied to the lighthouse’s exterior masonry was in fact a pigmented red limewash. While it is possible that the exterior brickwork of the lighthouse was originally unpainted and that the red-colored limewash was applied subsequently in order to refresh its red brick appearance, the lack of a distinct dirt layer between the surface of the brick and the first pigmented limewash suggests that the first red limewash layer is original. (Figures 5 and 6)

Historical documentation also provides information about the point in time when the masonry exterior of the lighthouse underwent this dramatic change. In 1873, the U.S. Light House Board directed that the lighthouse be painted in a new way in order to conform to new universal standards that gave each lighthouse along the Outer Banks a unique and discernible appearance. The new paint scheme called for the Cape Lookout Lighthouse to “be checkered, the checkers being alternatively black and white.”⁷ It is this pattern, dating from 1873, that is depicted in the historic photographs from 1899 and 1910, and which still adorns the lighthouse today. Although the paint type has changed, from traditional oil paints to more modern coatings, the color palette and pattern has been maintained since 1873. The HSR includes five references to the exterior of the tower being painted since 1873 (in 1885, 1992, 1995, 2000 and 2004). In each of these repainting campaigns, the black and white diagonal checkered pattern was re-applied. (Figures 7 and 8)

⁶ Oppermann, I.B.8.

⁷ Oppermann, I.B.18.

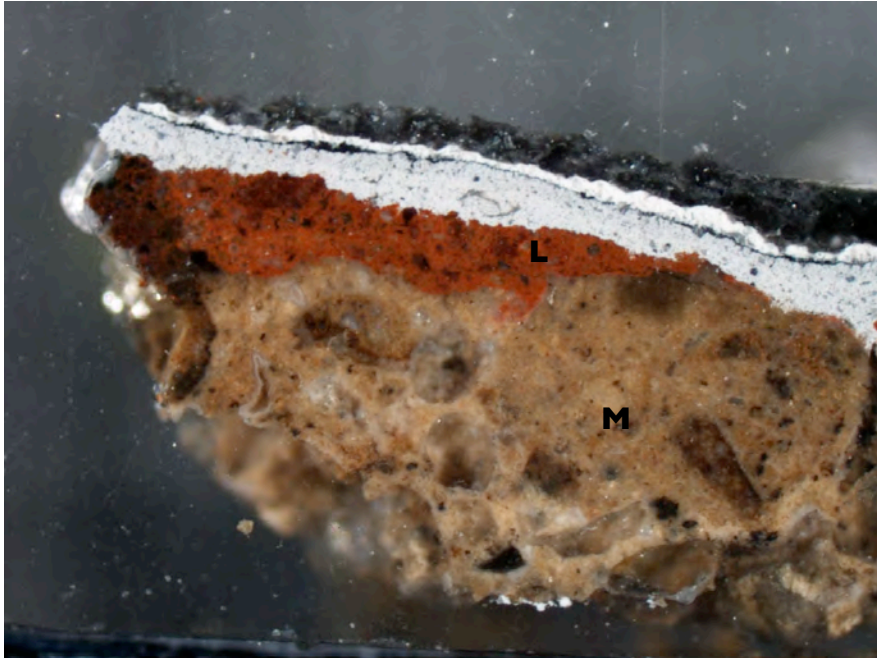

Figure 5. Cape Lookout Lighthouse. Photomicrograph of Sample CALO.E.11, removed from the exterior of the lighthouse shows the original red limewash (L) applied over brick mortar (M), followed by layers of modern black and white paint coatings. Photograph by author, 40x magnification.

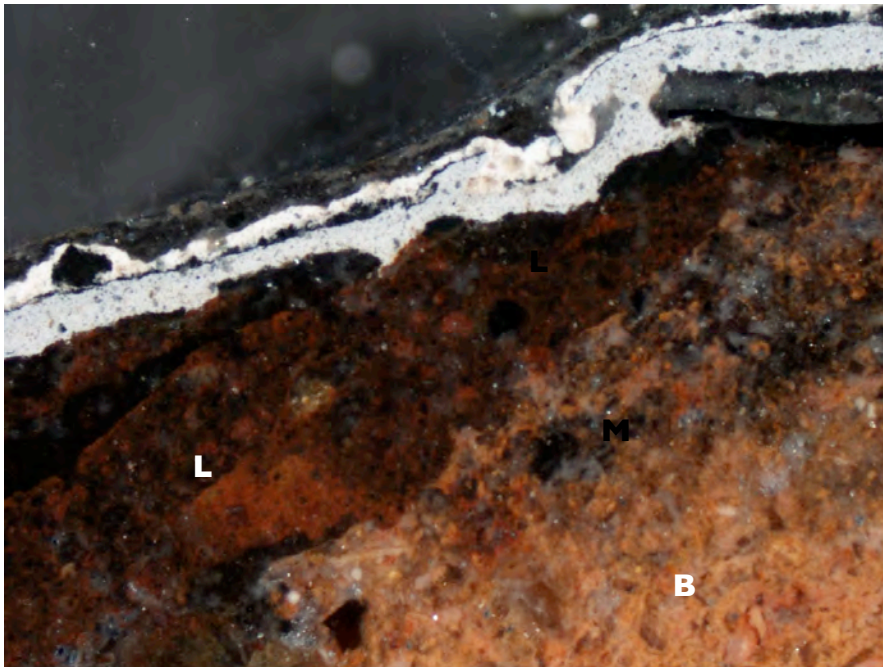

Figure 6. Cape Lookout Lighthouse. Photomicrograph of Sample CALO.E.10, removed from the exterior of the lighthouse shows the original red limewash (L) applied over brick substrate (B). Subsequent layers of black and white paint coatings are also visible. Photograph by author, 40x magnification.



Figure 7. Cape Lookout Lighthouse. A detail of an historic photograph of the lighthouse, dated 1899. This is the earliest known photograph of the lighthouse and shows its 1873 paint scheme. Photograph courtesy of Joseph K. Oppermann – Architect P.A.

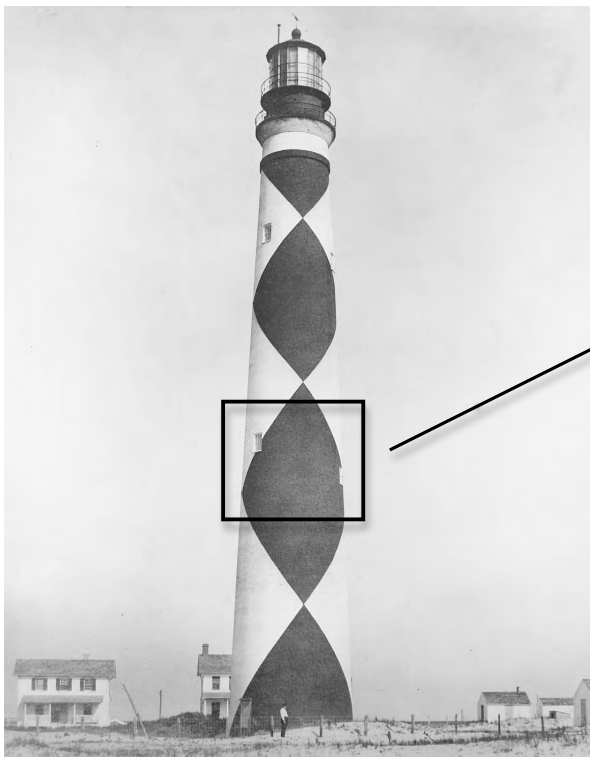

Figure 8. Cape Lookout Lighthouse. Another historic photograph, dated 1910. Note the light-colored window sash and frames, even in areas of black paint (inset). Photograph courtesy of Joseph K. Oppermann – Architect P.A.

It should be noted that, although no binder or pigment identification was performed as part of this study, the 1873 paint finish is most likely based on linseed oil and lead white pigment, which were the most widely used paint ingredients available at the time. Further testing would be required to confirm the composition of any paint layers.

In summary, both physical and archival evidence indicate that the black and white patterned paint scheme is not original to the lighthouse exterior and that, when the lighthouse was built in 1859, it was finished with a red limewash.

WOODWORK

As previously mentioned, the majority of the exterior woodwork on the lighthouse was damaged by Hurricane Fran and replaced in 1996. However, the historic (presumably original) window sash were salvaged and are in storage at the North Carolina Maritime Museum in Beaufort, North Carolina. These sash were examined as part of this study and were found to retain much of their paint history. Unfortunately, the original exterior doors were not located. (*Figure 9*)

The current paint scheme of the salvaged window sash examined for this study, which must have been located at the diagonal seam between black and white sections of the lighthouse exterior, is half black and half white. A paint sample was removed from the black portion of the sash and revealed approximately 15-20 layers of paint, the majority of which were white or off-white. Therefore, it appears that the exterior face of the sash was historically painted solid off-white, even when the black and white checkered pattern was applied to the lighthouse masonry. In fact, the historic photograph from the early 20th century, visible in *Figure 8*, shows a light-colored sash in one of the window openings within the black-painted area. It seems that the bi-color paint scheme on the sash is not original and that it is a fairly recent treatment. (*Figure 10*)

METALWORK

The exterior metalwork, which is limited to components of the lantern and observation deck levels, was also examined as part of this study. Unfortunately, the majority of the metalwork contains only recent paint and much of it, including the balconies, are non-original.

The lantern level metalwork (balcony floor and railings) was examined and found to only contain approximately 2-5 layers of modern black paint and no evidence of historic finishes. However, historic images of the lighthouse from 1899 and the early 20th century show a dark paint color on the metalwork of these areas. (*Figures 7 and 8*) More useful, however, is a statement in the 1859 *Notice to Mariners* that states that the lantern was painted black.⁸ Although the physical evidence is lacking, this

⁸ Oppermann, I.B.8.



Figure 9. Cape Lookout Lighthouse, October 2008. A salvaged window sash currently located at the North Carolina Maritime Museum. Two samples were removed from the exterior face of the sash (arrows). Photograph by author.

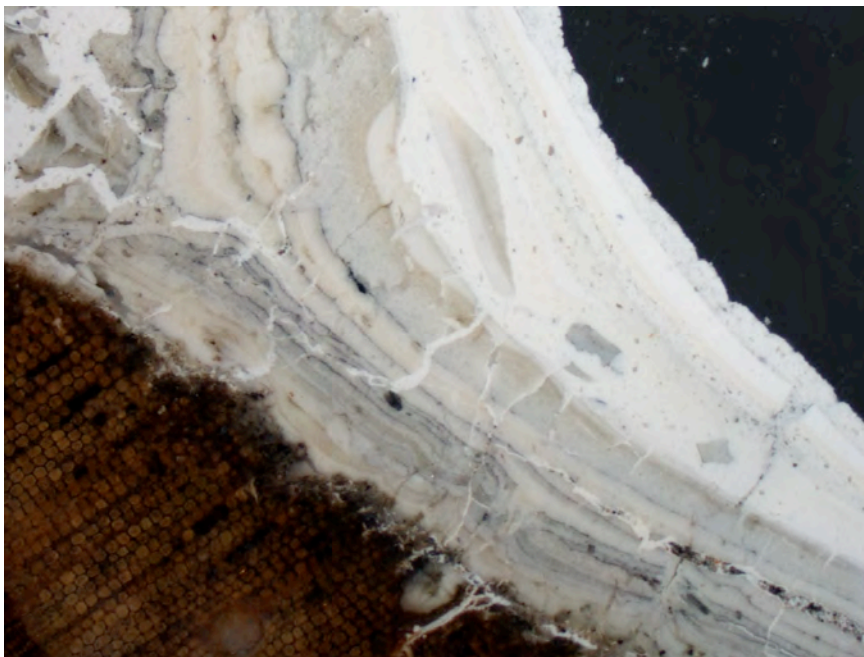

Figure 10. Cape Lookout Lighthouse. Photomicrograph of Sample CALO. SALV.3, which was removed from the exterior face of the salvaged window sash. Between 12 and 18 paint layers were found on the exterior face of the sash and the majority of the layers were off-white, even in the area currently painted black. This evidence suggests that the sash were painted off-white for the majority of the lighthouse's history. Photograph by author, 40x magnification.

recorded statement is solid evidence that the metalwork of the lantern level was originally painted black. The lantern was painted again in 1869, although the paint color is not included in this later reference.⁹ And in 1873, when the diagonal checkered pattern was applied to the lighthouse's masonry, the lantern was again noted as being painted black.¹⁰

The roof of the lantern, which is believed to be copper sheet, is currently painted black. Whether or not this paint color is original is not known, although both historic images of the lighthouse show a dark colored lantern roof. It would be unusual for a copper roof to be painted, as they were typically left unpainted and allowed to oxidize a pale blue-green. However, because black is a much more visible color (when viewed from the sea and against the sky), it is very possible that the copper roof was painted black. Access to this area was not possible, so its finish history could not be determined.

⁹ Oppermann, I.B.30

¹⁰ Oppermann, I.B.31

4.2 Interior Finishes Analysis

Because of recent restoration efforts, many of the historic interior finishes have been removed from the brick and metalwork of the interior. In addition, as previously mentioned, the window sash and frames have been replaced, so the amount of historic woodwork is also limited. While some areas of preserved finishes were located as part of this study, the majority of the finishes have been disturbed. The best evidence of interior finishes was found on the salvaged wood components currently in storage at the North Carolina Maritime Museum. These salvaged pieces include original window sash and sets of doors and associated beadboard partition walls that are believed to date to a 1914 period of modification.¹¹

MASONRY

The interior brick walls, which were blasted in 1996, currently contain minimal evidence of paint finishes. The entry vestibule walls and the floors of window wells contain some evidence of limewashes, but all other walls throughout the lighthouse are exposed brick. Historical accounts of other lighthouse in the same region, namely the Bodie Island Lighthouse to the north, indicate that the interior was typically whitewashed on a regular basis.¹² This would certainly be in keeping with nineteenth century practices of maintenance and hygiene. White limewash was found on the entry vestibule walls and also on the bottom four courses of brick in the boiler room (in a location that would have been under a wood platform and therefore protected), suggesting that historically a white limewash treatment may have been applied to the interior of the lighthouse. Unfortunately, the lack of physical evidence prevents this from being documented with any degree of certainty. (*Figures 11 and 12*)

WOODWORK

The interior woodwork of the Cape Lookout Lighthouse has a richer finishes history. In general, there is consistency between the paint evidence found on the salvaged woodwork and the pieces that remain in situ. On several pieces of interior woodwork, the earliest existing paint color is khaki. This color was found on a section of salvaged beadboard wall and associated interior door and frame, as well as on an in situ section of beadboard wall located on the service level of the lighthouse. These components of the lighthouse are believed to be contemporaneous, dating from a 1914 period of modification for the lighthouse.¹³ On the salvaged interior door, the khaki color was documented on rails and stiles but the panels were picked out in a dark green. (*Figures 13 and 14*)

The interior face of the salvaged sash (which dates to the original 1858-59 period of construction) does not contain the khaki, only numerous layers of white and off-white. Nor does the wood cabinet

¹¹ Based on conversation with Joseph Oppermann, February 6, 2009.

¹² Oppermann, I.A. 11

¹³ Based on conversation with Joseph Oppermann, February 6, 2009.

located at the watch level contain the khaki paint layer. Its earliest paint scheme consists of a dark, cool pale gray on the top surface of the cabinet and white on the face of the cabinet doors. Each area of the cabinet that was sampled contained only 5-6 layers of paint, suggesting the earliest paint layers may be missing. It is also possible that this piece was added to the lighthouse and is not original, meaning its historic paint scheme is not reflective of the lighthouse interior.

The lone wood stair landing in the lighthouse, which dates to 1867, also has evidence of a khaki color paint followed by several red-browns and blacks. Although similar to the khaki colored paint found on other elements of the interior woodwork, the earlier installation date of the floor prevents this khaki paint layer from being the same as that found on the doors and beadboard walls. It is possible, although unlikely, that the stair landing was stripped and re-painted in 1914 when the other modifications were made to the lighthouse interior. It is also possible that this khaki color was a primer for subsequent paint applications on the landing, which were predominantly red-brown in color. Unfortunately, the earliest paint finish for this landing remains unclear.



Figure 11. Cape Lookout Lighthouse, September 2008. Evidence of white limewash on the entry vestibule walls. All other finishes have been removed from the interior brick walls. Photograph by author.



Figure 12. Cape Lookout Lighthouse, September 2008. Additional evidence of limewash was found in the boiler room, in an area previously covered by a wood platform. Photograph by author.



Figure 13. Cape Lookout Lighthouse, October 2008. An interior door salvaged from the lighthouse and now in storage at the North Carolina Maritime Museum. Photograph by author.

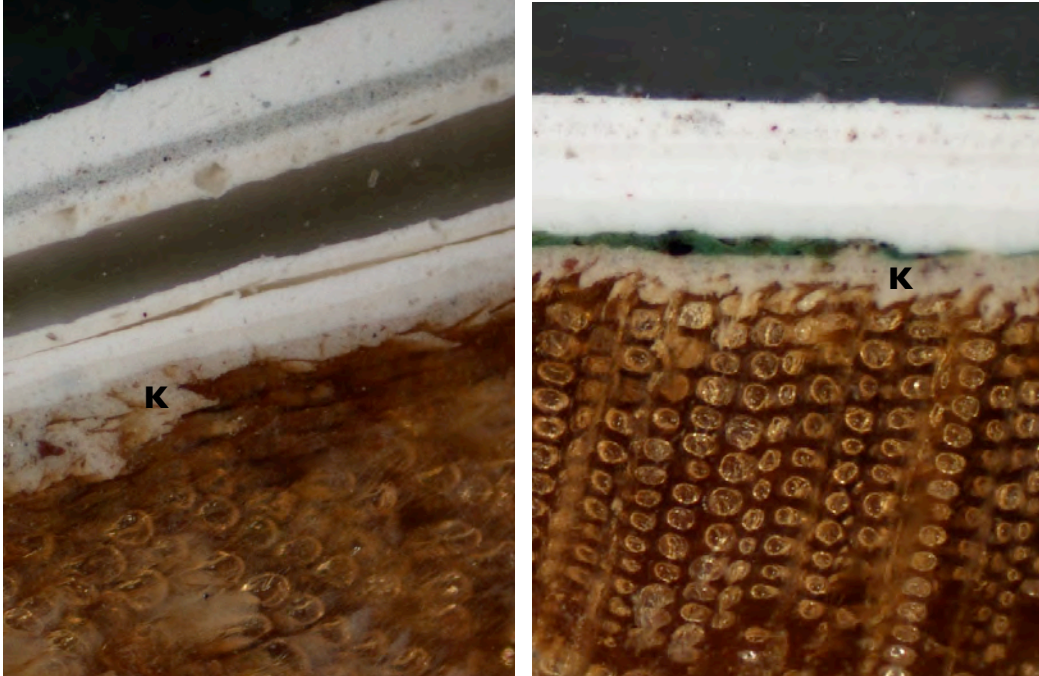

Figure 14. Cape Lookout Lighthouse. A comparison of two paint samples, CALO.SALV.4 (left) and CALO.SALV.5 (right), removed from the stile (left) and the recessed panel (right) of a salvaged interior door. Note the layer of dark green applied over the original khaki (K) paint only on the sample removed from the panel. This evidence suggests polychromy. Photograph by author, 100x magnification.

METALWORK

Like the exterior, the metalwork on the interior of the lighthouse contains very little evidence of historic paint finishes and it was difficult to compare paint layering sequences on various elements. The handrail of the stairs and most elements of the stairs, including treads and risers, contain only two layers of modern black paint.

The one metal component of the interior that contains numerous layers of paint, the earliest of which may be original, is the glazed lantern frame. Although the frame is composed of two different types of metal (ferrous vertical pieces and copper alloy horizontal pieces), they both appear to have always been painted some version of white. One area of the copper alloy component was sampled and was found to contain twelve layers of cream or white paint, sometimes applied over a red primer. A similar stratigraphy was found on the iron-based component. This light color for the interior of the lantern would have been important for reflecting the light from the lens. (*Figures 15 and 16*)

Other metal components of the interior were painted differently. The earliest paint color on the central cast iron column was dark green (two layers), followed by numerous red-browns and grays. The dark green was applied directly over a red primer on the metal, indicating it may have been original. In total, however, there were twelve layers of paint applied to the column. The earliest color on the cast iron stair treads was dark gray, followed by several red-browns and dark grays. This area also contained approximately twelve layers of paint. Although there are a fair number of paint layers on both of these interior elements, the lighthouse would have been well maintained and one would expect to find evidence of even more paint layers. There is unfortunately no way to determine whether or not the early dark green and gray paint colors on these metal components are original. (*Figures 17 and 18*)

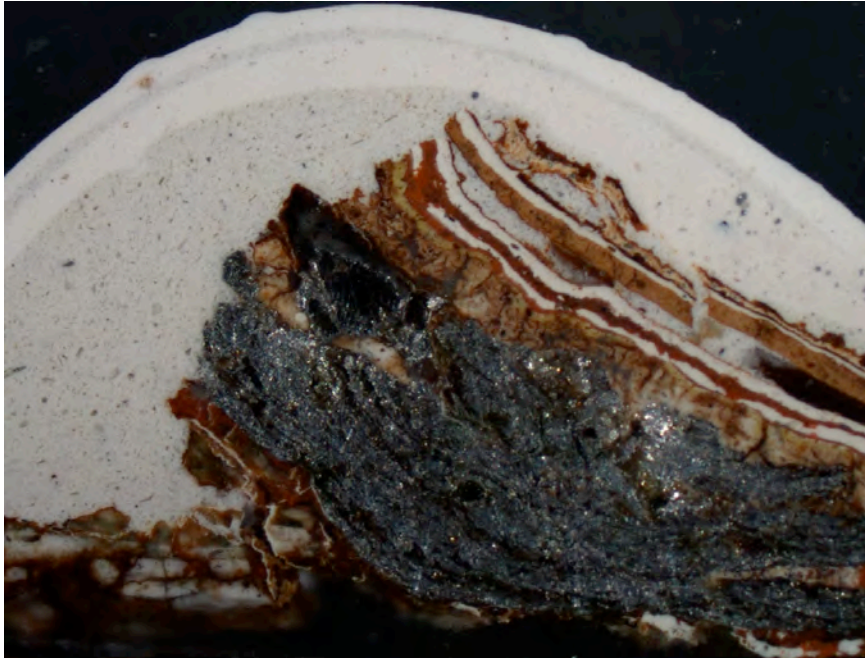

Figure 15. Cape Lookout Lighthouse. Photomicrograph of Sample CALO. 1.22, removed from one of the copper alloy components of the glazed lantern frame. Numerous layers of off-white (as well as primer red) are visible. There is also a thick metallic paint layer that was applied to the lantern interior fairly early in its history but is not original. Photograph by author, 40x magnification.



Figure 16. Cape Lookout Lighthouse, September 2008. Glazed lantern, interior face.

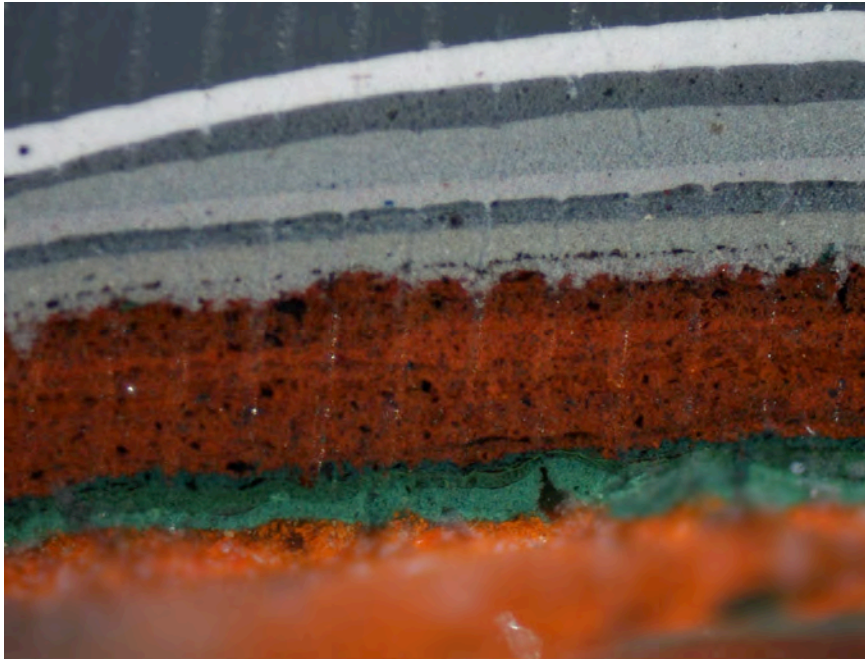

Figure 17. Cape Lookout Lighthouse. Photomicrograph of Sample CALO. I.3, removed from the astragal of the center cast iron column (at the Watch Level). Note the early red-orange primer followed by a dark green paint finish at bottom of photograph. This campaign may be original. Photograph by author, 100x magnification.



Figure 18. Cape Lookout Lighthouse, September 2008. Location of Sample CALO.I.3. Photograph by author.

4.3 Mortar Analysis

Laboratory analysis of mortar samples removed from two separate locations of brickwork indicates that the original mortar used at the lighthouse is a natural cement-based mortar with no lime addition. The mortar binder was further identified as a domestic product, even though both American and European natural cements were available during the time of the lighthouse's construction. Although the exact provenance of the cement could not be established, it is chemically consistent with cements produced in northwestern Georgia.

This mortar type differs from that used for the construction of the original Cape Lookout Lighthouse. If the Call for Proposals issued by the Treasury Department in 1810 represents the actual construction of the lighthouse, then it was built of "good lime mortar" and not a natural cement-based mortar.¹⁴ Lime-mortars were far more common than natural cement mortars at this early point in the 19th century, as production of natural cements did not begin in earnest until the construction of the Erie Canal in 1819.¹⁵

A natural cement is defined as an eminently hydraulic lime that is typically derived from the burning of highly impure limestone. It is these impurities that give the lime the characteristic of hydraulicity, or the ability to set by reaction with water (no air is needed, unlike with pure high calcium limes). Natural cements differ from Portland cements, which were produced later, in that the latter are artificially produced. Portland cements of the 19th century were made by grinding together chalk and clay and then heating the mixture at high temperatures to produce a simulated natural cement. Both natural and Portland cements can have quite high strength and durability.

Natural cement based mortars were quite common in the mid to late 19th century and would have been readily available at the time of the lighthouse's construction. The use of natural cements specifically for maritime construction, pioneered by Englishman James Smeaton in the late 18th century, was also common and has been documented at other sites in the United States, namely Fort Adams in Rhode Island and Fort Jefferson in Florida.¹⁶

In addition to the binder of the Cape Lookout Lighthouse mortar, the aggregate portion of the mortar was also examined. The sand used for the mortar was identified as a clean and narrowly graded siliceous aggregate typical of a fine beach sand, most likely harvested from the Outer Banks region. It is light brownish-gray in color (Munsell 10YR 6.5/1.5) and contains traces of carbonate shell fragments and coal dust, although the latter most likely represents contaminants from the binder.

¹⁴ Oppermann, I.B.2.

¹⁵ Eckel, Edwin C. *Cements, Limes and Plasters. Reprinted Third Edition.* Dorset: Donhead Publishing, 2005. Page 242.

¹⁶ Martin, Mary Catherine, "Military Experiments with Lime and Hydraulic Cement Mortars in Seacoast Fortifications", paper presented at 2003 APTI Conference, Portland, Maine.

Although finding a source for the original sand was not included in this study, a sample of the sand adjacent to the lighthouse was removed from the site for visual comparison with the sand extracted as part of the analysis. The sand in the brick mortar is darker in color than the sample of sand removed from the island and does not appear to be an exact match.

The average binder to sand ratio for the mortar was identified as 1 part binder to 1.5 parts sand (1: 1.6 for sample CALO. Mortar.1 and 1: 1.3 for sample CALO. Mortar.2). While these proportions may be considered quite binder-rich by contemporary standards, ratios of 1: 1 and 1: 2 were typical for 19th century natural cement mortars.¹⁷ In addition, although non-hydraulic lime was sometimes added to natural cement mortars to retard set and increase workability, the Cape Lookout Lighthouse mortar shows no evidence of any addition of lime.

For a more in depth discussion of the specific findings of the mortar analysis performed as part of this study, including detailed characterization of the aggregate and binder as well as annotated photomicrographs, refer to *Appendix C*.

¹⁷ Baker, Ira O. *A Treatise on Masonry Construction. 9th Edition.* New York: John Wiley & Sons, 1906. Page 85.



Figure 19. Cape Lookout Lighthouse, September 2008. Area of typical interior brickwork showing the brick's hand-pressed, low-fired quality and appearance. Photograph by author.



Figure 20. Cape Lookout Lighthouse, September 2008. An area where inappropriate Portland cement based re-pointing mortar has caused the original brick to spall and the original mortar to deteriorate. Photograph by author.

4.4 Brick Analysis

The bricks that the Cape Lookout Lighthouse is constructed of are low-fired and handmade, with subtle variations in color and texture due to the low temperature firing process. There are also numerous visible inclusions of aggregate and clay, as well as evidence micro-cracks from the forming process. Although much of the brickwork on the exterior of the building is obscured by paint, the interior brick is currently exposed. (*Figured 19 and 20*)

Laboratory analysis was performed on brick units removed from the interior of the ground floor boiler room of the lighthouse. Testing included compressive strength and water absorption, in accordance with ASTM C 67-07. The results of the testing indicate that all brick samples tested meet the ASTM-established absorption requirements and that the majority of the brick samples meet the compressive strength requirements for Grade MW (moderate weathering).

The results of the testing indicate that the compressive strength of the bricks is better than expected, typically exceeding the ASTM minimum requirement for Grade MW (moderate weathering) brick. In addition, 50% of the time the compressive strength for individual brick exceeded the minimum requirement for Grade SW (severe weathering) brick. The average gross area compressive strength of the four brick samples tested is 2,720 psi. The minimum requirement for the gross area compressive strength of Grade MW bricks is 2,500 psi and for Grade SW is 3,000 psi.

Results of the absorption testing indicate that the average absorption of the brick samples is below the maximum average of the ASTM requirements for both Grade SW and Grade MW, and the results meet the individual requirements for absorption. The average saturation coefficient of the bricks tested is also below the maximum average requirement for Grade SW and Grade MW.

Based on the results of the testing, the brick can be considered adequate in terms of meeting the basic requirements for MW (moderate weathering) grade brick and is perfectly suitable for their intended use at the lighthouse. Areas of distress noted on the interior of the lighthouse seem to be related to re-pointing campaigns in which hard, Portland cement-based mortars were used. The condition of the brick on the exterior of the lighthouse is unknown. The brick were reportedly blasted with water in the 1990s to prepare for a re-painting campaign and were then subsequently covered with thick, non-breathable coatings. These actions may have harmed the brick by removing portions of the outer fireskin and also trapping in moisture, conditions which may affect their overall water absorption and possibly their compressive strength properties. Additional testing of brick removed from the exterior is also recommended to ensure that the physical properties of the brick have not been adversely impacted by the blasting and current paint coatings.

For a more in depth discussion of the specific findings of the brick analysis performed as part of this study, including all laboratory data, refer to *Appendix D*.

5.0 CONCLUSIONS AND RECOMMENDATIONS

5.1 Finishes

Making recommendations for appropriate restoration finishes for the lighthouse poses some challenges. Firstly, some of the building's paint evidence has been lost and much of the woodwork replaced; preventing historic paint finishes from being documented for certain elements. In addition, making recommendations to restore the paint colors to a specific point in time is not altogether straightforward. This is due to the fact that the National Park Service may decide not to recreate the lighthouse's original paint scheme since its current appearance, although not original, has become somewhat iconic and is historic in its own right. Fortunately, many of the lighthouse's architectural features retained a consistent color palette for the majority of their life, making recommendations for these elements easier. Because of the possibility of two different periods of interpretation for the lighthouse, recommendations and color matches are provided for paint finishes from both of these significant historic periods whenever possible.

Please note that the lack of surviving physical evidence prevents recommendations from being made for certain elements of the lighthouse. This is particularly true of the building's metal components (interior and exterior), which have been stripped and re-painted numerous times over the course of the lighthouse's history. The Munsell and Benjamin Moore color matches provided below are based solely on surviving physical evidence and are only for those paint colors known to date to 1858-59 or 1873. However, when archival information (written or photographic) indicates a color for an element that no longer contains physical paint evidence, a description of the original color is included below but without a specific color match.

The recommended paint colors for restoration are provided below. Specific color matches have been made to both the standardized Munsell color system and the commercial Benjamin Moore paint palette. Please note that any attempt to reproduce this page, including printing from the electronic version of the report, will distort the color of the provided chips. Only the actual color chip or notation should be used for paint replication purposes.

EXTERIOR

	1858-59	Ca. 1873
Brick Masonry	Red Limewash Munsell 10R 4/8 Benjamin Moore 035	Alternating Black and White Munsell N 0.5 & 10YR 9/2 Benjamin Moore Black & OC-34
Window Sash	Off-white Munsell 5Y 9/2 Benjamin Moore OC-13	Off-white [Based on Archival Photographs - No Match Provided]
Window Frames	Inconclusive [No Match Provided]	Off-white [Based on Archival Photographs - No Match Provided]
Lantern	Black [Based on Written Archival Documentation - No Match Provided]	Black [Based on Archival Photographs - No Match Provided]

INTERIOR

	1858-59	1873
Brick Masonry	Inconclusive, Possibly White Limewash [Based on Written Archival Documentation - No Match Provided]	Inconclusive, Possibly White Limewash [Based on Written Archival Documentation - No Match Provided]
Window Sash	Off-white Munsell 5Y 9/2 Benjamin Moore OC-13	Inconclusive, Possibly Off-white [No Match Provided]
Window Frames	Inconclusive [No Match Provided]	Inconclusive, Possibly Off-white [Based on Archival Photographs - No Match Provided]
Watch Level Cabinets	Inconclusive [No Match Provided]	Inconclusive [No Match Provided]

	1858-59	1873
Stair Handrails	Inconclusive, Possibly Black [No Match Provided]	Inconclusive, Possibly Black [No Match Provided]
Lantern Frame	Inconclusive, Possibly White [No Match Provided]	Inconclusive [No Match Provided]
Central Cast Iron Column	Dark Green Munsell 2.5G 4/4 Benjamin Moore 630	Inconclusive [No Match Provided]
Stair Treads	Inconclusive, Possibly Dark Gray [No Match Provided]	Inconclusive [No Match Provided]

	1858-59	1873
Wood Stair Landing	[Non-Applicable, Dates to 1867]	Inconclusive [No Match Provided]
Interior Doors and Bead Board Walls [Note: These elements date to 1914]	[Non-Applicable, Dates to 1914]	Khaki & Green(1914 paint scheme) Munsell 5Y 6/1 & 10GY 3/4 Benjamin Moore 1537 & 637

5.2 Masonry

Analysis of the brick masonry and mortar of Cape Lookout Lighthouse indicates that the original construction was composed of low-fired brick laid up with a natural cement mortar. These materials are typical for the period and especially for maritime construction of the period. The masonry system has apparently held up well through the years, even in the harsh maritime environment of wind and salt-laden sea air. However, the full extent of the brick and mortar condition cannot be determined because of the thick synthetic paint coatings applied on the exterior of the lighthouse. It is safe to say, however, that the impervious modern coatings are not appropriate for the masonry and are most likely trapping moisture in the walls and exacerbating any existing deterioration. Evaluation of this aspect of the masonry construction falls outside of the scope of this research.

In addition to inappropriate exterior masonry coatings, the lighthouse has also undergone some incompatible masonry repairs. These repairs used dense mortars based on Portland cement and often replacement bricks that do not match the original brick, neither visually nor dimensionally. The Portland cement-based repairs are particularly problematic, as they have caused significant albeit localized damage to the original masonry adjacent to the repair area. This damage is visible in repair areas on the inside walls of the lighthouse. The extent of the re-pointing on the exterior (and any damage it may be causing) is unknown because of the existing paint coatings.

For future re-pointing campaigns, it is important that the correct mortar be used. It may also be prudent to replace existing repair campaigns with a more appropriate mortar. Mortars based on large amounts of Portland cement are typically too strong and dense to be used in combination with the type of low-fired brick and, as previously mentioned, have already caused damage to the lighthouse. However, the use of a high calcium or hydraulic lime mortar would also be inappropriate. Current research and recently completed restoration projects have documented the failure of such mortars in similar buildings in coastal environments.

The recommended restoration mortar for the Cape Lookout Lighthouse is as follows:

Binder: natural cement (available from Edison Coatings)

Sand: fine grayish brown siliceous sand (to match provided sieve analysis and sand sample)

Component Ratio (binder: sand): 1:1.5

APPENDIX A.

KEY TO SAMPLE LOCATIONS

**CAPE LOOKOUT
PAINT SAMPLE LIST**

Sample Number	Level	Location	Notes
CALO.I.1	Watch	Interior, wood cabinet, top	Top, at areas of paint buildup from vertical membrane (now gone).
CALO.I.2	Watch	Interior, wood cabinet, front	Front T&G door.
CALO.I.3	Watch	Interior, center column shaft, astragal	
CALO.I.4	Watch	Interior, cast iron stair, tread	Between watch and lantern levels.
CALO.I.5	Watch	Interior, door to balcony, surround	Interior face; 1914 addition.
CALO.I.6	Lantern	Interior, glass lantern; vertical frame member	Interior face of ferrous member.
CALO.I.7	Lantern	Interior, glass lantern; horizontal frame member	Interior face of copper alloy member.
CALO.I.8	Lantern	Interior, cast iron platform	Below rotating lens.
CALO.I.9	Service	Interior, T&G boardwall, board	1914 addition.
CALO.I.10	Service	Interior, T&G boardwall, door casing	1914 addition.
CALO.I.11	Service	Interior, stair tread, underside	Between service and watch level.
CALO.I.12	Service	Interior, cast iron column, from landing	
CALO.I.13	Service	Interior, handrail, just before boardwall of service level	
CALO.I.14		Interior, stair tread	Between service level and Landing 6.
CALO.I.15		Interior, center column	Between service level and Landing 6.
CALO.I.16		Interior, landing, underside, I-beam support	
CALO.I.17		Interior, wood	

Sample Number	Level	Location	Notes
		stair landing	
CALO.I.18	2 nd fl. level	Interior, door frame at entry to 2 nd floor level	
CALO.I.19	Machinery Room	Machinery room, interior.	Finishes on brick.
CALO.I.20		Wood stair landing, floor.	Finishes on wood.
CALO.I.21		Wood stair landing, brick window well.	Finishes on brick.
CALO.I.22	Lantern	Bronze lantern frame.	Paint on bronze.
CALO.I.23		Handrail.	Paint on ferrous metal.
CALO.E.1	Watch	Exterior, metal door, surround	1914 addition.
CALO.E.2	Watch	Exterior, balcony, underside	Lantern level cast iron observation deck.
CALO.E.3	Watch	Exterior, metal railing	Rounded connection joint.
CALO.E.4	Watch	Exterior, copper sheet metal conical cover	For interior air vent.
CALO.E.5	Watch	Exterior, brick masonry	
CALO.E.6	Lantern	Exterior, observation deck, cast in place floor,	
CALO.E.7	Lantern	Exterior, observation deck, copper alloy vertical member.	
CALO.E.8	Ground	Exterior, paint on brick.	Currently white.
CALO.E.9	Ground	Exterior, paint on brick.	Currently black.
CALO.E.10	Ground	Exterior, paint on brick.	
CALO.E.11	Ground	Exterior, paint on mortar.	

Sample Number	Level	Location	Notes
CALO.SALV.1	N/A	Salvaged, window sash, interior face, stile.	
CALO.SALV.2	N/A	Salvaged, window sash, exterior face, stile, black portion.	
CALO.SALV.3	N/A	Salvaged, window sash, exterior face, stile, white portion.	
CALO.SALV.4	N/A	Salvaged, storage level door, rim lock face, lock stile.	
CALO.SALV.5	N/A	Salvaged, storage level door, door knob/rosette face, bottom recessed panel.	
CALO.SALV.6	N/A	Salvaged, storage level door frame	
CALO.SALV.7	N/A	Salvaged, storage level door frame, beadboard wall above.	
CALO.SALV.8	N/A	Salvaged, unlabeled door, rim lock face, hinge stile.	
CALO.SALV.9	N/A	Salvaged, unlabeled door, door knob/rosette face, hinge stile.	

APPENDIX B.

**SAMPLE STRATIGRAPHIES AND
PHOTOMICROGRAPHS**

CAPE LOOKOUT LIGHTHOUSE PAINT STRATIGRAPHY

EXTERIOR

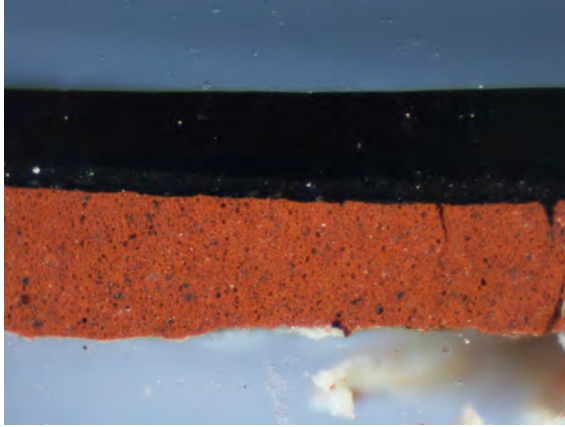

Visible light, 40x

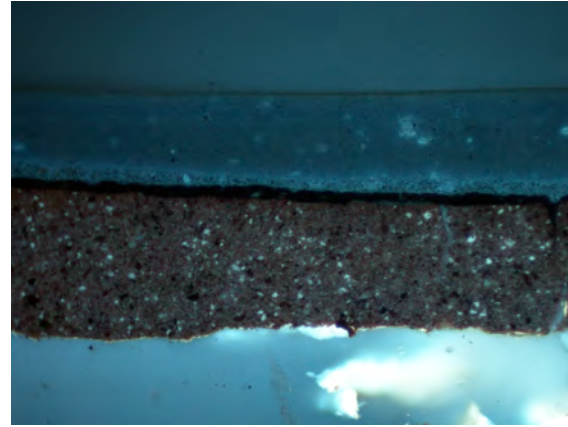

UV light. 40x

SAMPLE NO:	CALO.E.1
LOCATION:	Watch Level, metal door, surround

LAYER*	COLOR (VL)	COLOR (UV)	NOTES
Substrate	Metal		
1	Pale green	Green	Traces
2	red	dark gray	
3	black	light gray	
4	black	gray	
5			
6			
7			
8			
9			
10			
11			

***bold** indicates a finish layer

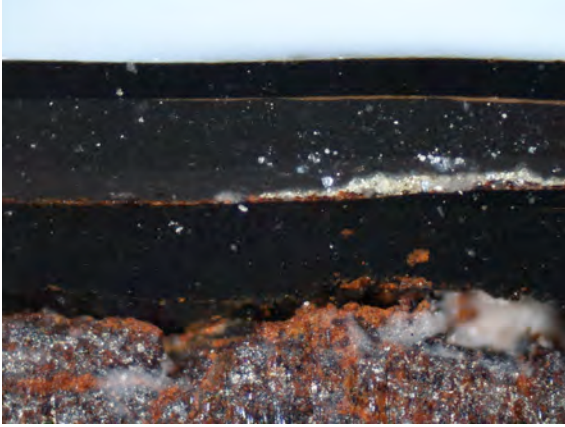

Visible light, 100x



UV light. 100x

SAMPLE NO:	CALO.E.2
LOCATION:	Watch Level, Balcony, underside

LAYER*	COLOR (VL)	COLOR (UV)	NOTES
Substrate	Metal-Rust		
1	Black		
2	Black		
3	Black		
4			
5			
6			
7			
8			
9			
10			
11			

***bold** indicates a finish layer



Visible light, 40x

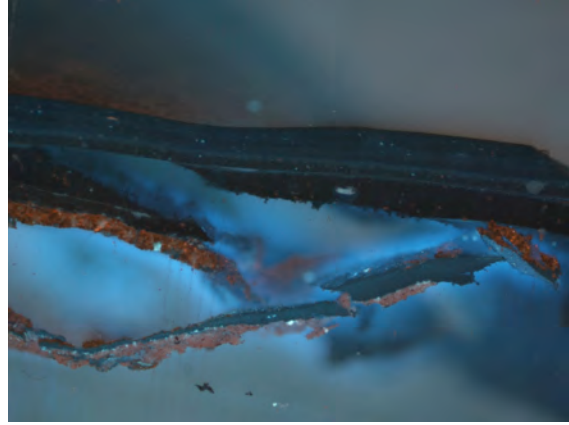

UV light. 40x

SAMPLE NO:	CALO.E.3a
LOCATION:	Watch Level, metal railing

LAYER*	COLOR (VL)	COLOR (UV)	NOTES
Substrate			
1	Red		Primer
2	Black		
3	Silver		Primer
4	Black		
5	Black		
6	Black		
7	Black		
8	Black		
9			
10			
11			

***bold** indicates a finish layer

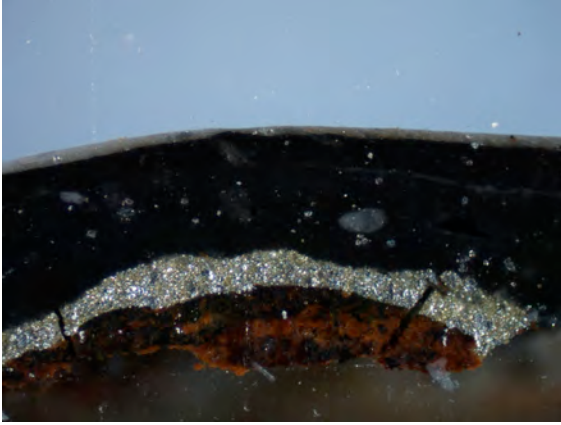

Visible light, 100x

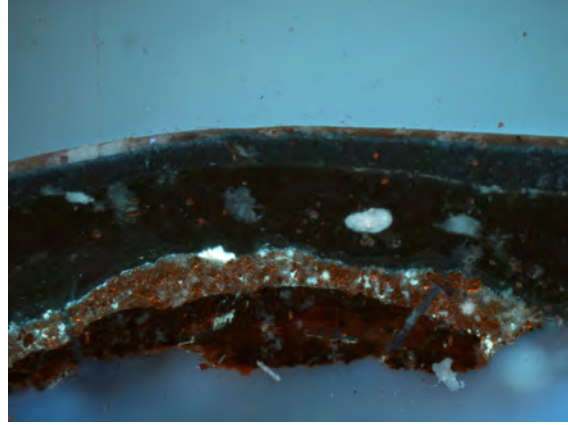

UV light. 100x

SAMPLE NO:	CALO.E.3b
LOCATION:	Watch Level, metal railing

LAYER*	COLOR (VL)	COLOR (UV)	NOTES
Substrate	Metal		
1	Silver	Red	
2	Black	Black	
3	Black	Black	
4	Black	Brown	
5	Black		
6			
7			
8			
9			
10			
11			

***bold** indicates a finish layer

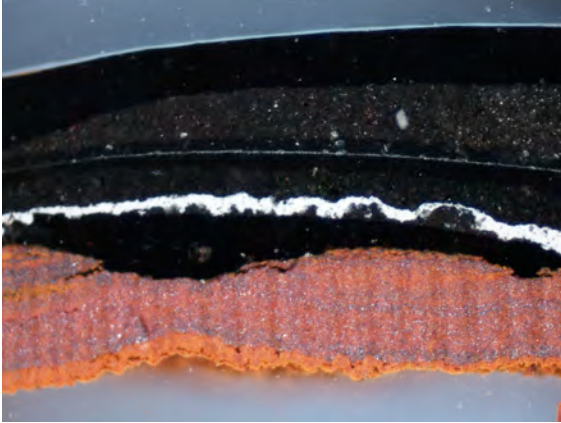

Visible light, 100x

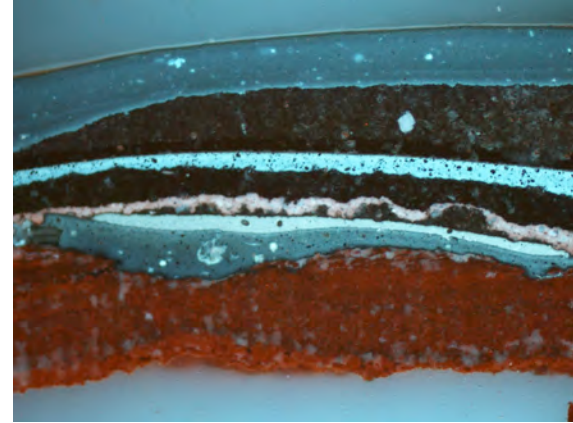

UV light. 100x

SAMPLE NO:	CALO.E.4
LOCATION:	Watch Level, copper sheet metal conical cover

LAYER*	COLOR (VL)	COLOR (UV)	NOTES
Substrate			
1	Red-orange		Primer
2	Red		
3	Black	Blue-green	
4	Black	Light blue-green	
5	Black	Dark gray	Uneven, weathered
6	White	White	
7	Black	Black	
8	Black	Bright blue-green	
9	Black	Black	Thick
10	Black	Light blue-green	Thick
11	Black	Dark gray	Very thin
12			

***bold** indicates a finish layer



Visible light, 100x

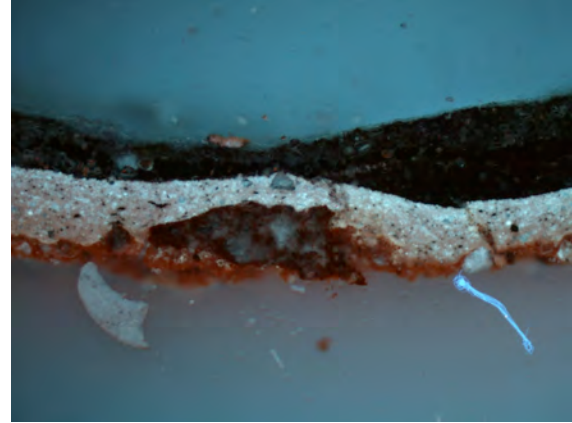

UV light, 100x

SAMPLE NO:	CALO.E.5a
LOCATION:	Watch Level, brick masonry

LAYER*	COLOR (VL)	COLOR (UV)	NOTES
Substrate	Brick		
1	Red-orange	Red-orange	Limewash
2	Red	Dark red	Limewash? Brick?
3	White	White	
4	Black	Black	
5	Black	Gray	
6			
7			
8			
9			
10			
11			

***bold** indicates a finish layer

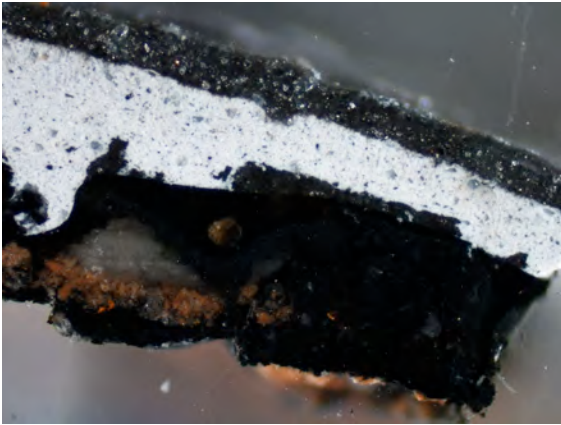

Visible light, 100x

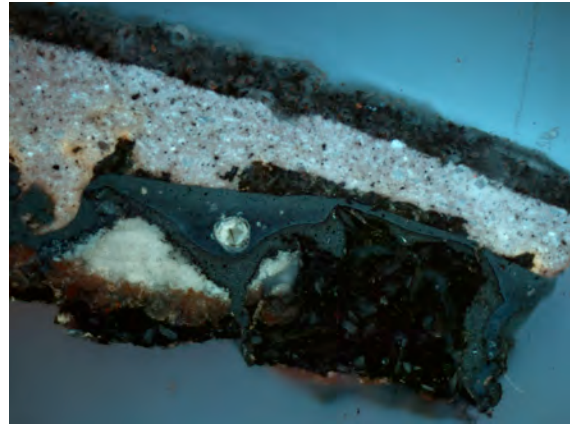

UV light. 100x

SAMPLE NO:	CALO.E.5b
LOCATION:	Watch Level, brick masonry

LAYER*	COLOR (VL)	COLOR (UV)	NOTES
Substrate	Brick		
1	Black	Dark gray	
2	Black	Dark blue-gray	Smooth
3	Black	Dark Gray	Not continuous
4	White	White/iridescent	
5	Dark gray	Gray	
6			
7			
8			
9			
10			
11			

***bold** indicates a finish layer

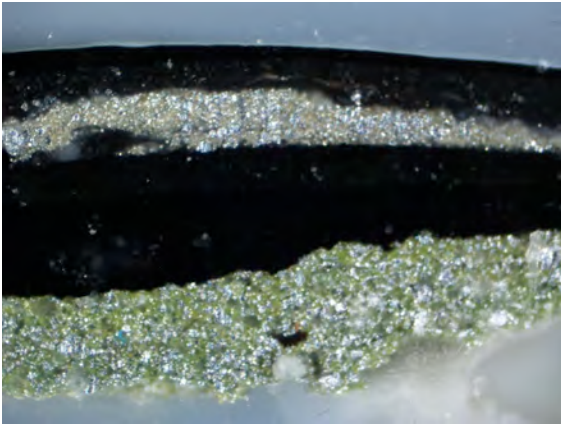

Visible light, 100x

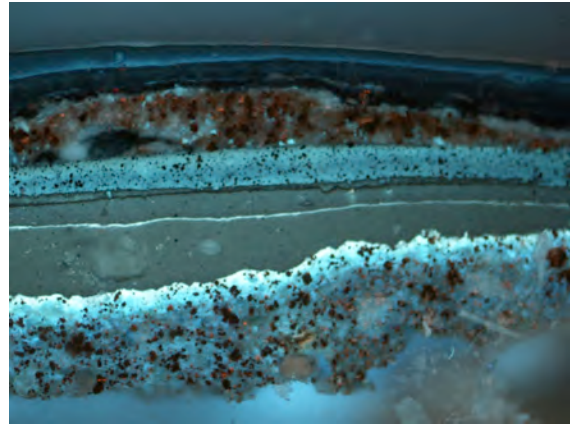

UV light. 100x

SAMPLE NO:	CALO.E.6
LOCATION:	Lantern Level, Observation Deck, cast iron plate floor

LAYER*	COLOR (VL)	COLOR (UV)	NOTES
Substrate			
1	Reflective green	Blueish-white matrix	Heterogenous pigment particles fluorescing differently; primer
2	Black	Gray	Smooth
3	Black	Blue-green	Very thin
4	Black	Gray	Smooth
5	Dirt		
6		Gray	Very thin
7	Dirt		
8	Black	Blue-green	
9	Silver	Multi-color	
10	Black	Gray	
11	Black	Blue	
12	Black	Gray	

***bold** indicates a finish layer

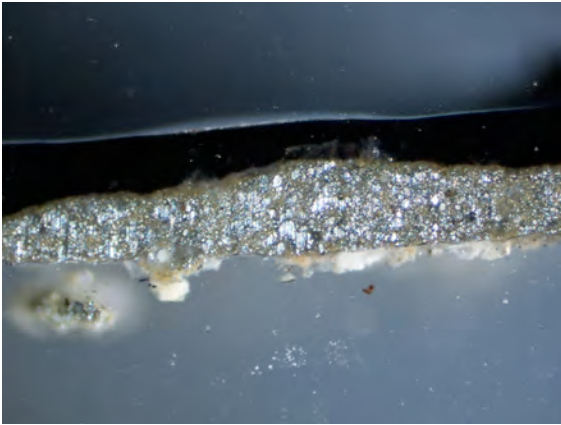

Visible light, 100x

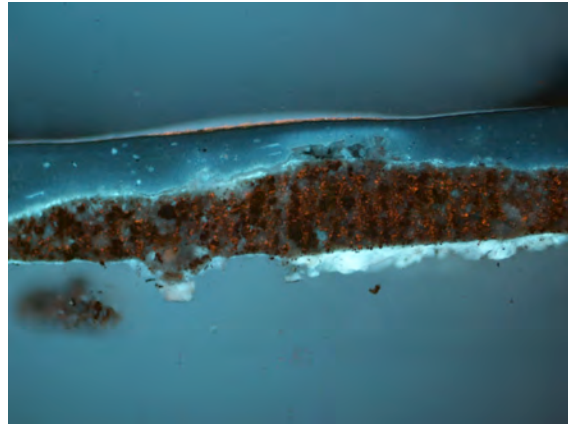

UV light. 100x

SAMPLE NO:	CALO.E.7
LOCATION:	Lantern Level, Observation Deck, copper alloy vertical member

LAYER*	COLOR (VL)	COLOR (UV)	NOTES
Substrate			
1	White/tan	Blue-green	Paint? Oxidation?
2	Silver	Multi-color	Thick; primer – seems to match to later layers in CALO.E.6 suggesting this is a later finish and was either unpainted or had earlier paint removed
3	Black	Blue	
4			
5			
6			
7			
8			
9			
10			
11			

***bold** indicates a finish layer

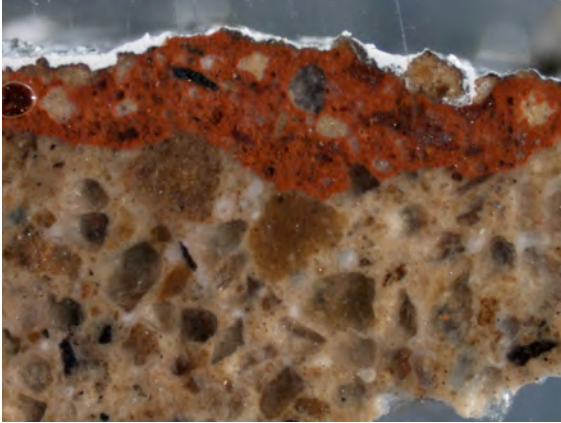

Visible light, 40x

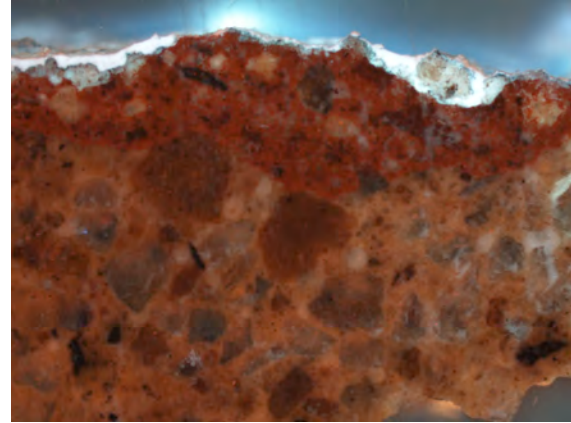

UV light. 40x

SAMPLE NO:	CALO.E.8a
LOCATION:	Exterior paint on brick

LAYER*	COLOR (VL)	COLOR (UV)	NOTES
Substrate	Mortar		
1	Red	Red	Limewash
2	White	White	Paint
3			
4			
5			
6			
7			
8			
9			
10			
11			

***bold** indicates a finish layer

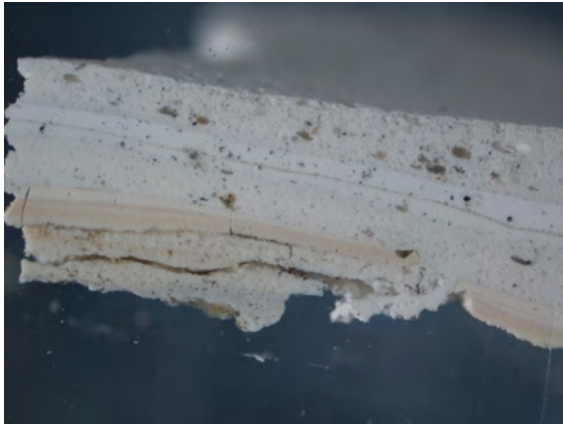

Visible light, 40x

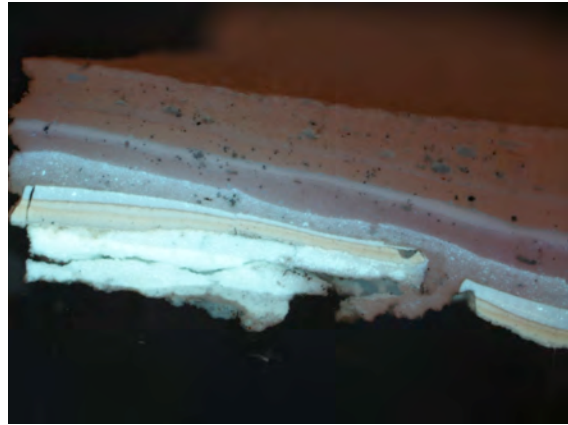

UV light. 40x

SAMPLE NO:	CALO.E.8b
LOCATION:	Exterior paint on brick, currently white

LAYER*	COLOR (VL)	COLOR (UV)	NOTES
Substrate	Brick		
1	Red		Limewash (see sample E.8a)
2	Gray-white	Bright gray	
3	Creamy white	Bright white	Separated within – not continuous
4	Off-white	Blue-green	
5	Dirt/separation		
6	Pinky-white	Off-white	
7	Pinky-white	Bright pinky-white	
8	Pinky-white	Cream	
9	Creamy white	Bright blue-green	Thin
10	White	Blue-green	
11	White	Pink	
12	White	White	
13	Dirt		
14	White	Pink	
15	Gray-white	Pink	
16			

***bold** indicates a finish layer

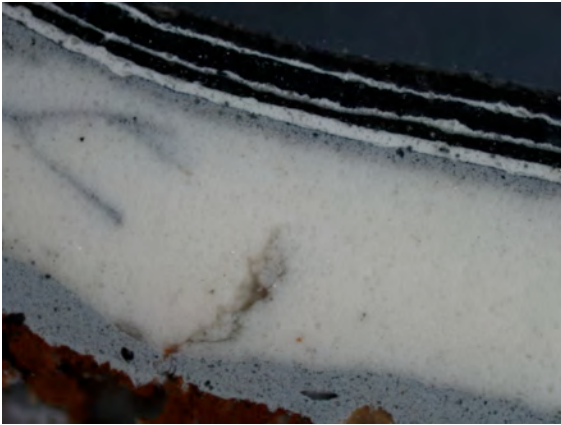

Visible light, 40x

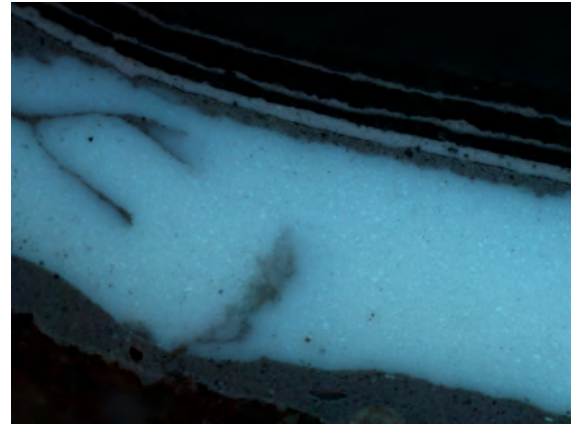

UV light. 40x

SAMPLE NO:	CALO.E.9
LOCATION:	Exterior paint on brick, currently black

LAYER*	COLOR (VL)	COLOR (UV)	NOTES
Substrate	Brick		
1	Red		limewash
2	Gray	Gray	
3	White	Blue-green	Very thick
4	Gray	Gray	
5	Dirt		
6	White	White	
7	Black	Black	
8	White	White	Thin
9	Black	Black	
10	White	White	Thin
11	Black	Black	

***bold** indicates a finish layer

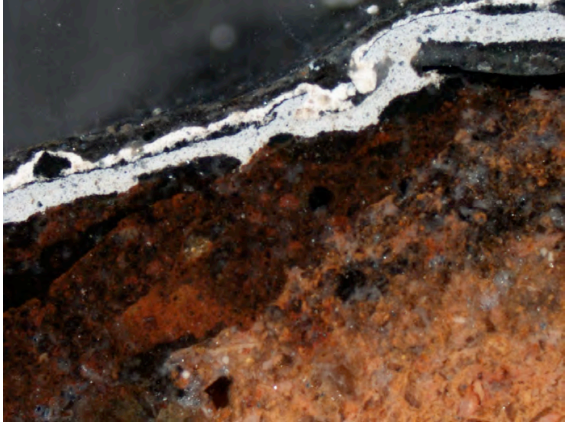

Visible light, 40x

SAMPLE NO:	CALO.E.10
LOCATION:	Exterior paint on brick.

LAYER*	COLOR (VL)	COLOR (UV)	NOTES
Substrate	Brick		
1	Orange-red		limewash
2	Brown-red		limewash
3	Black		
4	Black		
5	Gray		
6	White		
7	Black		
8	White		
9	Black		

***bold** indicates a finish layer

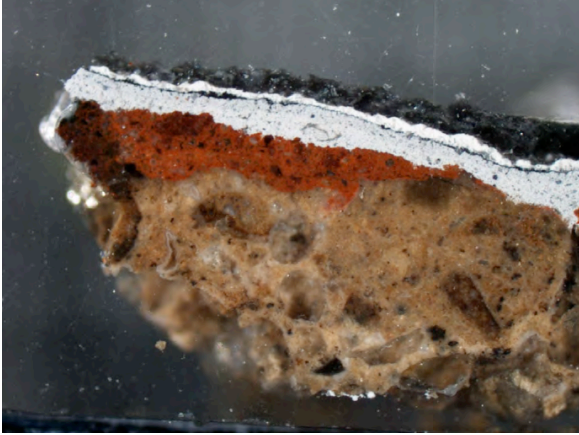

Visible light, 40x

SAMPLE NO:	CALO.E.11
LOCATION:	Exterior paint on mortar.

LAYER*	COLOR (VL)	COLOR (UV)	NOTES
Substrate	Brick		
1	Orange-red		limewash
2	Brown-red		limewash
3	Black		
4	Black		
5	Black		
6	White		
7	Black		
8	White		
9	Black		
10	White		
11	Black		

***bold** indicates a finish layer

INTERIOR



Visible light, 40x

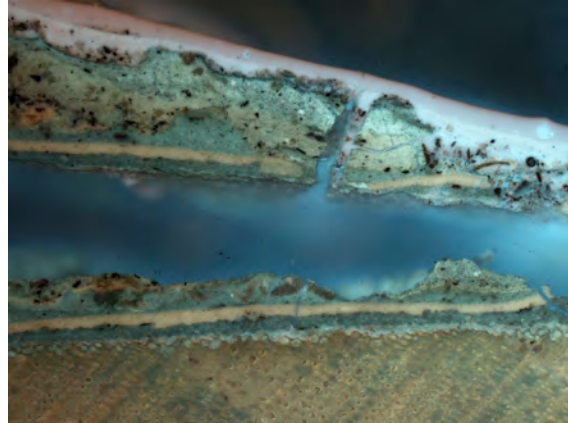

UV light. 40x

SAMPLE NO:	CALO.I.I
LOCATION:	Watch Level, wood cabinet, top

LAYER*	COLOR (VL)	COLOR (UV)	NOTES
Substrate	Wood		
1	White/Light gray		Very, very thin and uneven
2	Gray	Gray	
3	Dirt		
4	White	Cream	
5	Gray	Gray	Uneven, weathered
6	Dirt		
7	Light gray	Green	Uneven – separation at this layer
8	Dirt		
9	White		
10	White	Pink	
11			
12			
13			

***bold** indicates a finish layer

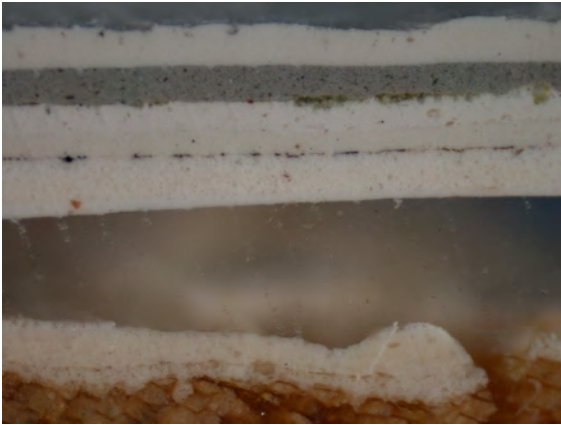

Visible light, 100x

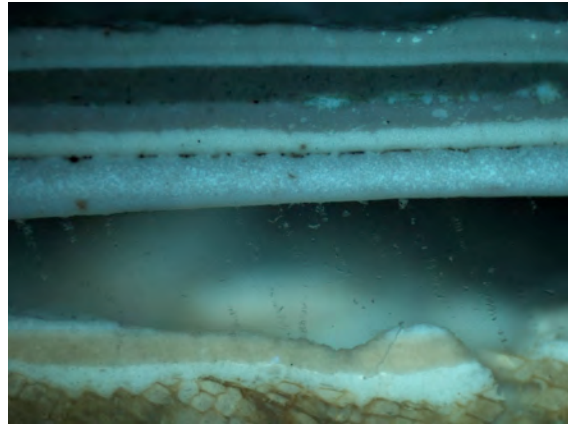

UV light. 100x

SAMPLE NO:	CALO.I.2
LOCATION:	Watch Level, wood cabinet, front

LAYER*	COLOR (VL)	COLOR (UV)	NOTES
Substrate	Wood		
1	Beige	Bright white	
2	Creamy White	Bright beige	Separation at this layer
3	White	Blue-green	
4	Dirt		
5	Creamy White	Bright white	
6	White	Bright gray	
7	Dirt		
8	Gray	Dark gray	
9	White	Blue-green	
10			
11			

***bold** indicates a finish layer

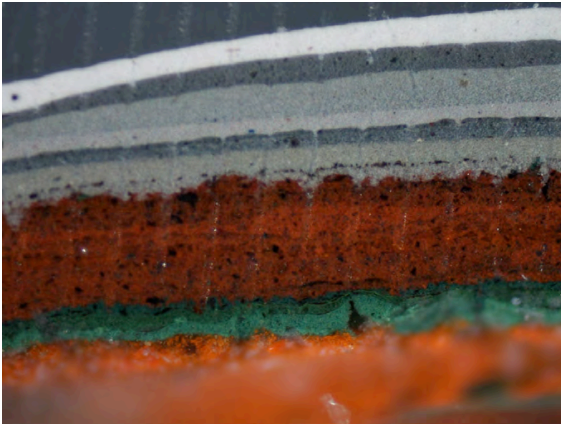

Visible light, 100x

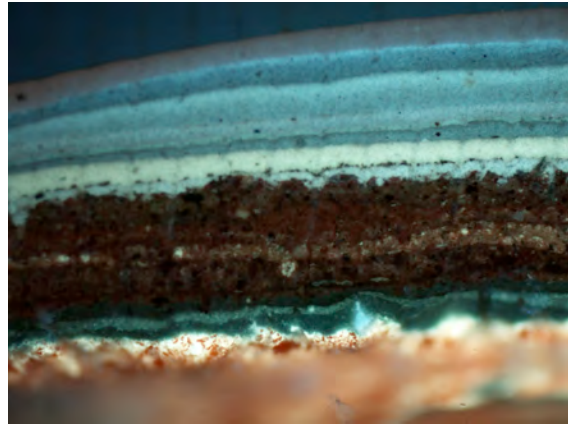

UV light. 100x

SAMPLE NO:	CALO.I.3
LOCATION:	Watch Level, center column shaft, astragal

LAYER*	COLOR (VL)	COLOR (UV)	NOTES
Substrate	Metal		
1	Orange		Primer
2	Green		
3	Dark Green		
4	Dark Green		
5	Red		Thick, primer, heavily prepped surface
6	Light gray		
7	Blue-gray		
8	Gray		
9	Light Gray		
10	Blue-gray		
11	Gray		
12	White		

***bold** indicates a finish layer

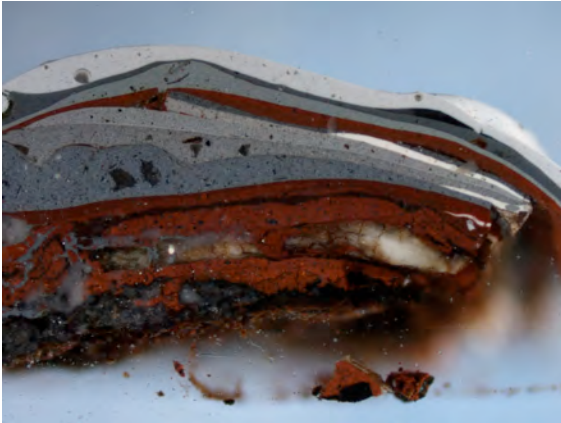

Visible light, 40x

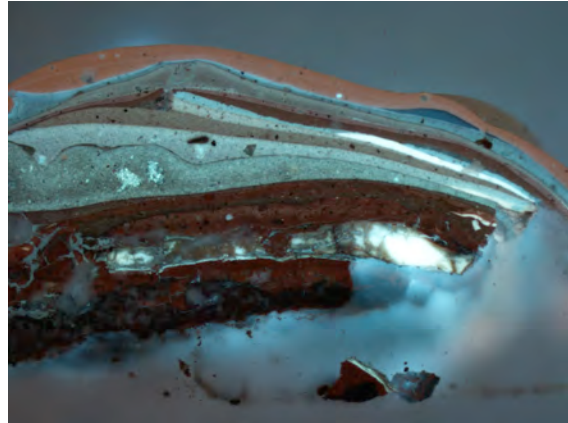

UV light. 40x

SAMPLE NO:	CALO.I.4
LOCATION:	Watch Level, Cast iron stair, tread, between watch and lantern levels

LAYER*	COLOR (VL)	COLOR (UV)	NOTES
Substrate	Metal		
1	Gray		
2	Dark Gray/Black		
3	Red		Primer
4	Red		Primer
5	White?		Very distressed layer
6	Red		
7	Red		
8	Brown-red?		
9	Red		
10	Blue-gray		
11	Gray		

***bold** indicates a finish layer

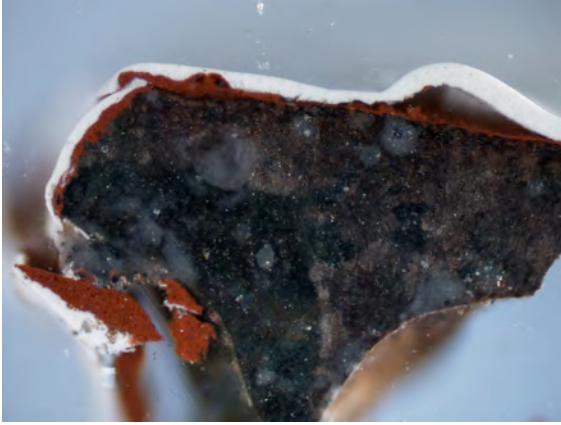

Visible light, 100x

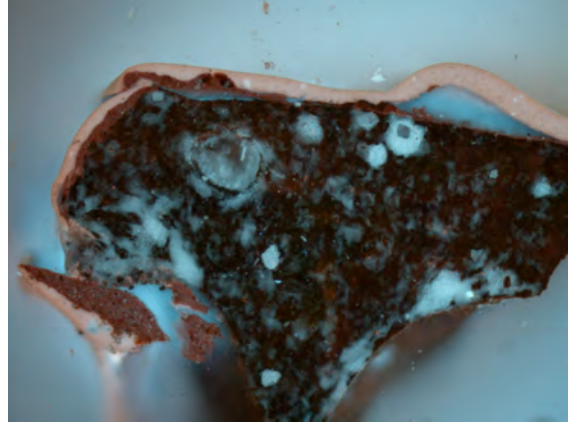

UV light. 100x

SAMPLE NO:	CALO.I.5
LOCATION:	Watch Level, door to balcony, surround, interior face

LAYER*	COLOR (VL)	COLOR (UV)	NOTES
Substrate	Metal		
1	Dark Gray		Fill
2	Black		
3	Red	Red	
4	White	Pink	
5			
6			
7			
8			
9			
10			
11			

***bold** indicates a finish layer

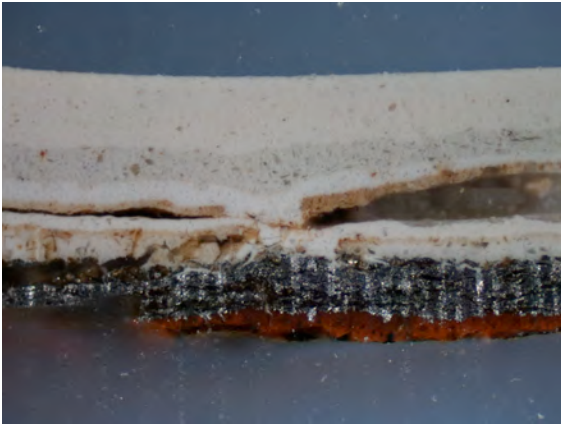

Visible light, 100x

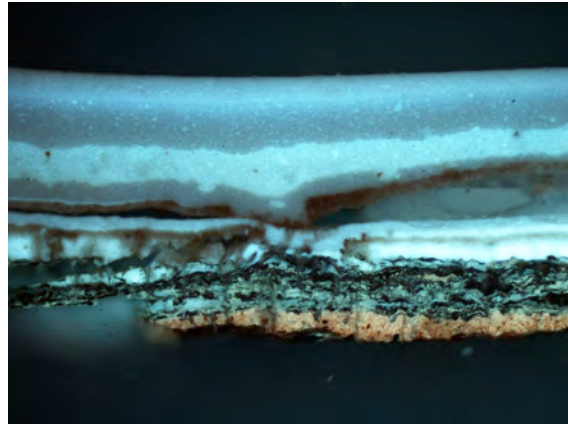

UV light. 100x

SAMPLE NO:	CALO.I.6
LOCATION:	Lantern Level, glass lantern vertical frame member, interior face

LAYER*	COLOR (VL)	COLOR (UV)	NOTES
Substrate	Metal		
1	Red	Brown	Primer
2	Silver	Multi-color	Primer
3	White	Blue-green	
4	Beige	Beige	Thin
5	White	Blue-green	Separation at this layer
6	Beige/Tan	Brown	
7	White	Light gray	
8	Light gray	Blue-green	
9	White	Bright gray	
10	White	Bright blue-green	
11			

***bold** indicates a finish layer

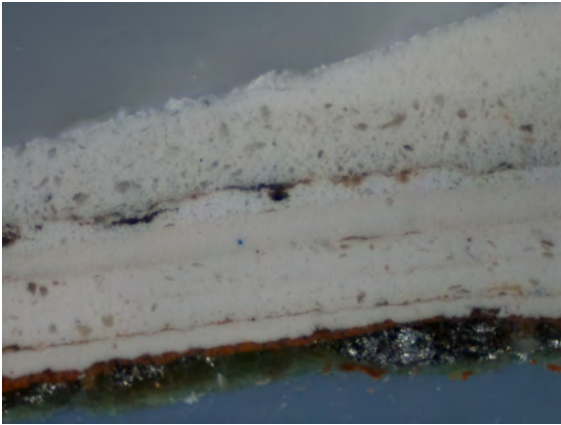

Visible light, 200x

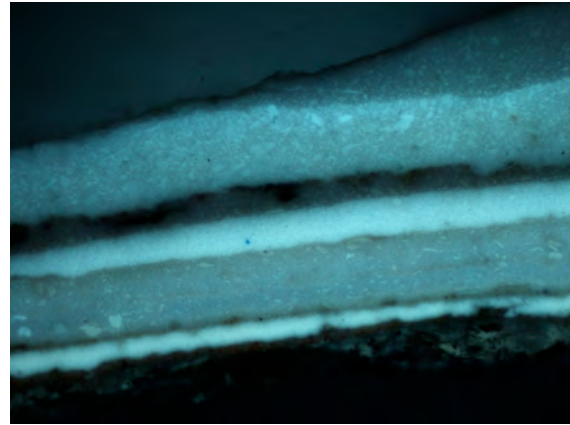

UV light. 200x

SAMPLE NO:	CALO.I.7
LOCATION:	Lantern Level, glass lantern horizontal frame member, interior face

LAYER*	COLOR (VL)	COLOR (UV)	NOTES
Substrate			
1	Green	n/a	Thin, uneven
2	Silver	Multi-color	Not continuous
3	Red-orange	n/a	Thin, uneven
4	White	Blue-green	
5	Dirt/separation		
6	White	Blue-green/gray	
7	White	Blue-green	
8	White	n/a	
9	White	n/a	Uneven
10	Dirt		
11	White	Bright blue-green	
12	White	Blue-green/gray	

***bold** indicates a finish layer



Visible light, 100x

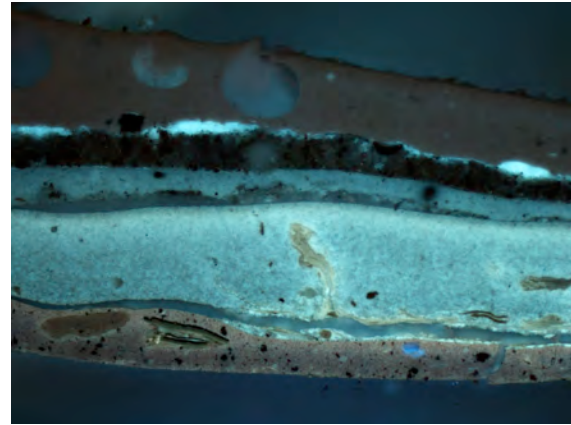

UV light. 100x

SAMPLE NO:	CALO.I.8
LOCATION:	Lantern Level, cast iron platform, below rotating lens

LAYER*	COLOR (VL)	COLOR (UV)	NOTES
Substrate			
1	Red	Beige/Pink	Primer
2	Dirt/separation		
3	Light gray	Bright blue-green	Primer
4	Gray	Gray	Uneven
5	Gray	Blue-green	
6	Silver	n/a	
7	Dark gray	Bright blue-green	
8	White		
9			
10			
11			

***bold** indicates a finish layer



Visible light, 40x

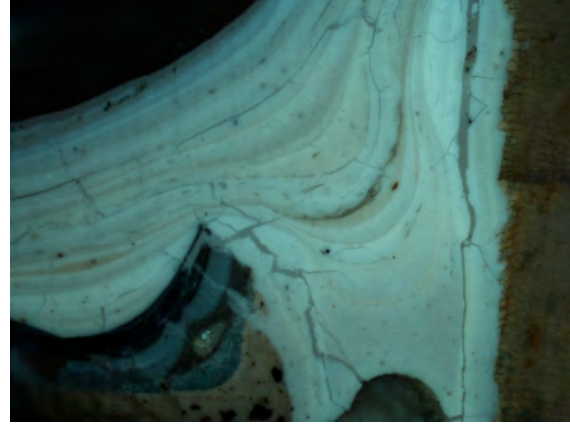

UV light. 40x

SAMPLE NO:	CALO.I.9
LOCATION:	Service Level, tongue and groove boardwall board

LAYER*	COLOR (VL)	COLOR (UV)	NOTES
Substrate	wood		
1	Lt. khaki/wm. gray	Dark	
2	Cream	Blue-white	
3	Off-white		
4	White		
5	White	Blue-white	
6	White	Blue-white	
7	cCeam	Blue-white	
8	Cream	White	
9	Cream	Blue-white	
10	Cream		
11	Off-white	Dark	
12	White	Blue-white	
13	White		

***bold** indicates a finish layer

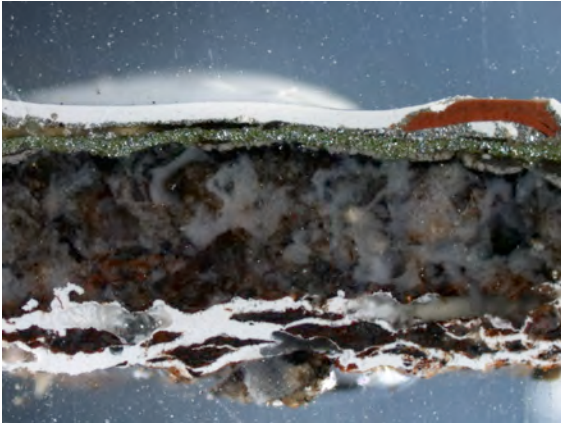

Visible light, 40x

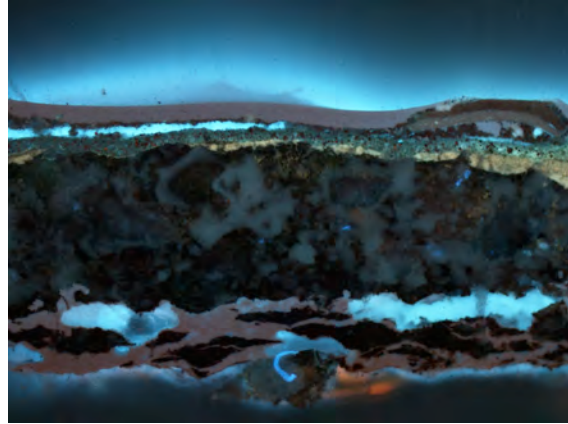

UV light. 40x

SAMPLE NO:	CALO.I.I.I
LOCATION:	Service Level, Stair tread, underside, between service and watch levels

LAYER*	COLOR (VL)	COLOR (UV)	NOTES
Substrate	Metal		
1	Dark gray		Thick
2	Black		Partial
3	Beige	Brown	
4	Dark Gray	Brown	
5	Iridescent green		
6	Silver		Partial
7	Red		Partial
8	Red		Partial
9	White		
10			
11			

***bold** indicates a finish layer

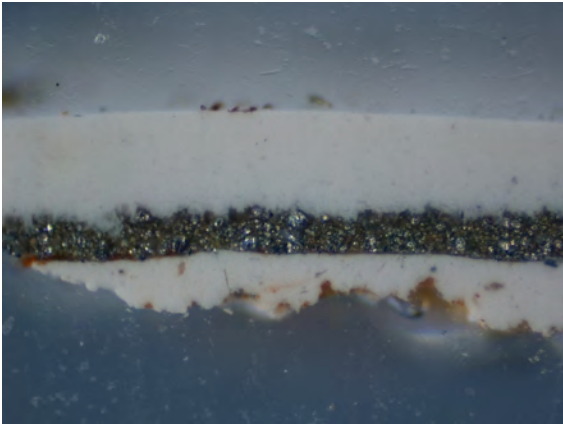

Visible light, 200x

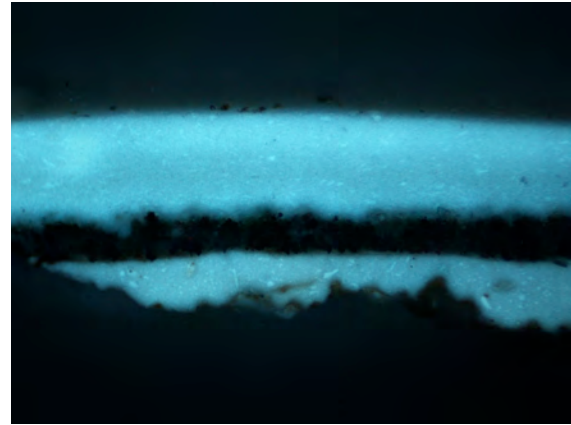

UV light. 200x

SAMPLE NO:	CALO.I.I2
LOCATION:	Service Level, cast iron column, from landing

LAYER*	COLOR (VL)	COLOR (UV)	NOTES
Substrate			
1	Brown	Brown	
2	White	Blue-green	
3	Orange		Partial
4	Silver	n/a	
5	White	Blue-green	
6			
7			
8			
9			
10			
11			

***bold** indicates a finish layer

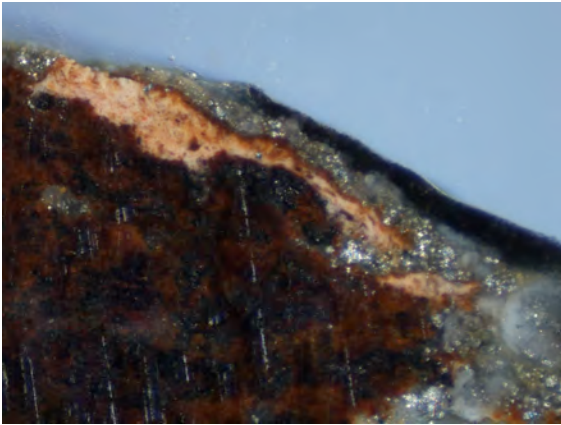

Visible light, 200x

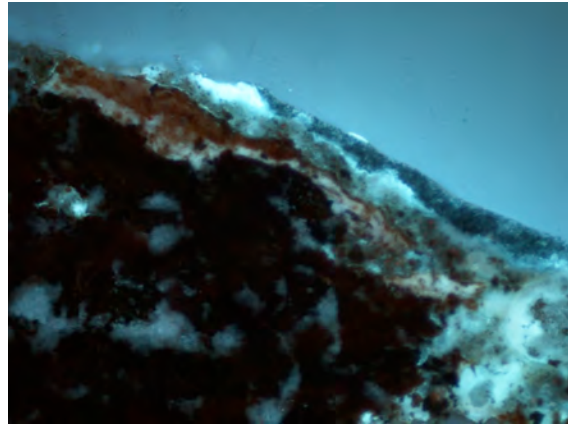

UV light. 200x

SAMPLE NO:	CALO.I.13
LOCATION:	Service Level, handrail, just before beadborad wall of service level

LAYER*	COLOR (VL)	COLOR (UV)	NOTES
Substrate			
1	Beige	Multi-color	
2	Beige	n/a	
3	Red	n/a	
4	Silver/green		
5	Black	Blue	
6			
7			
8			
9			
10			
11			

***bold** indicates a finish layer

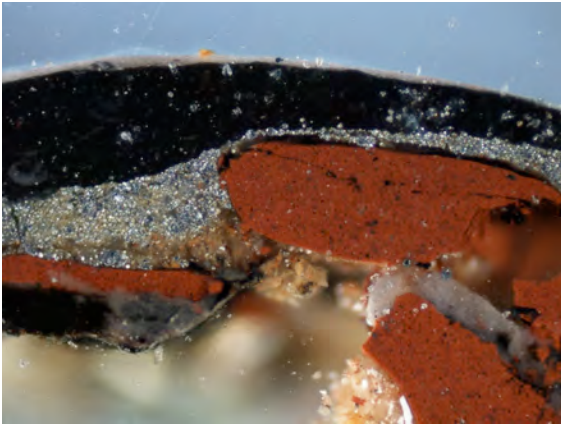

Visible light, 100x

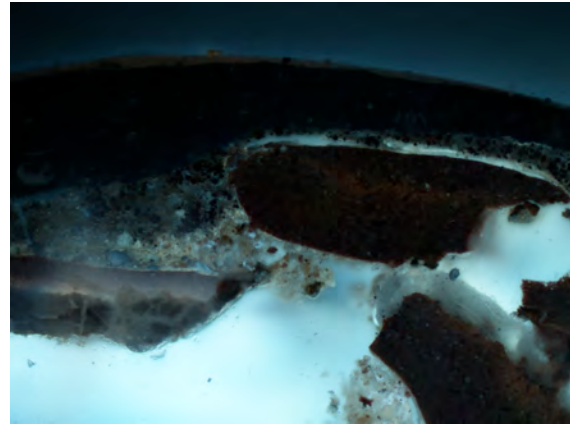

UV light. 100x

SAMPLE NO:	CALO.I.14
LOCATION:	Service Level, stair tread between service level and landing

LAYER*	COLOR (VL)	COLOR (UV)	NOTES
Substrate			
1	Black	Gray	
2	Red	Beige	
3	Silver		
4	Black	n/a	
5	White	n/a	
6			
7			
8			
9			
10			
11			

***bold** indicates a finish layer

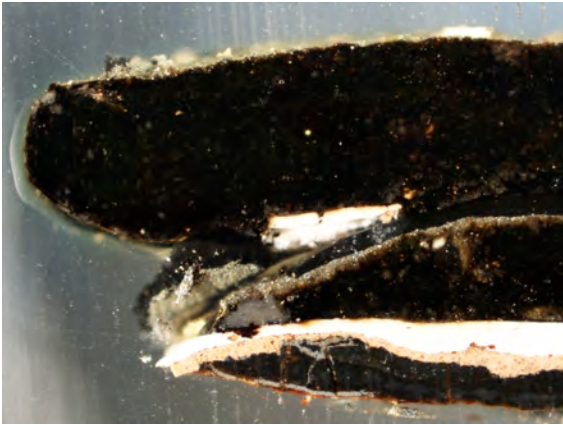

Visible light, 40x

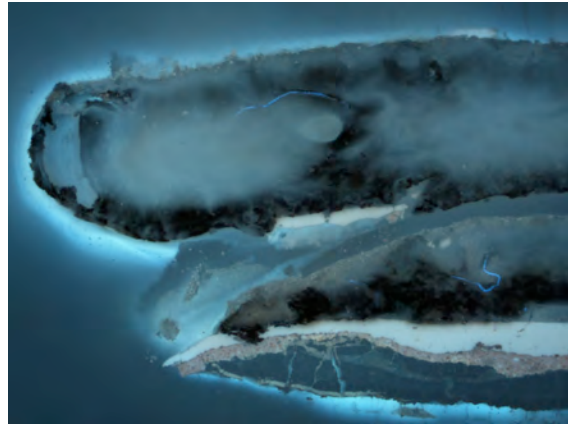

UV light. 40x

SAMPLE NO:	CALO.I.I15
LOCATION:	Service Level, center column, between service level and landing

LAYER*	COLOR (VL)	COLOR (UV)	NOTES
Substrate	Metal		
1	Light Gray		
2	Dark gray/Black		
3	Dark gray/Black		
4	Light Gray		
5	Beige		
6	White		
7	Brown		
8	Silver		
9	Black		
10			
11			

***bold** indicates a finish layer

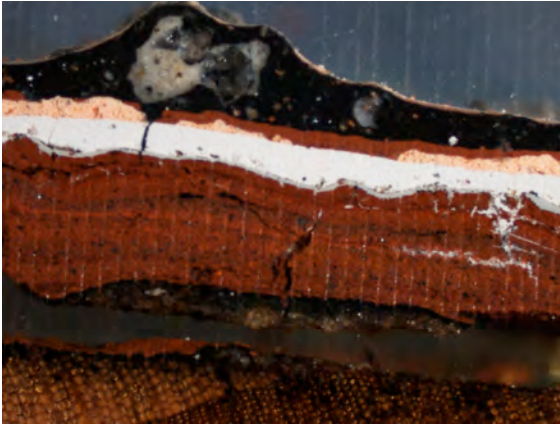

Visible light, 40x

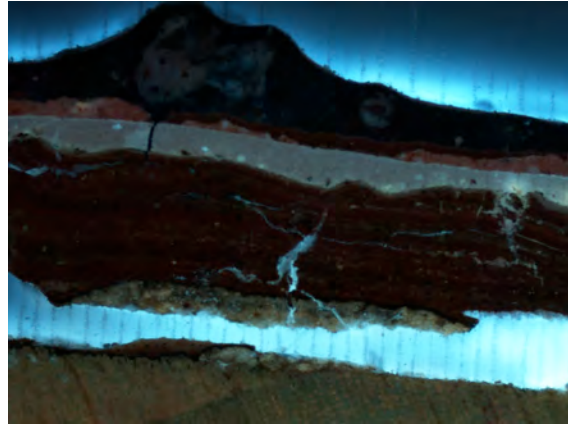

UV light. 40x

SAMPLE NO:	CALO.I.17
LOCATION:	Service Level, wood stair landing

LAYER*	COLOR (VL)	COLOR (UV)	NOTES
Substrate	Wood		SHOULD RELATE TO I.14
1	Brown		
2	Black		
3	Red-brown	n/a	Cracks within
4	Red-brown		
5	Red-brown		
6	Red-brown		
7	Light gray	Light gray	
8	Dirt		
9	White	Light gray	
10	Beige	Pink	Should relate to other samples
11	Red	n/a	
	Black	n/a	

***bold** indicates a finish layer

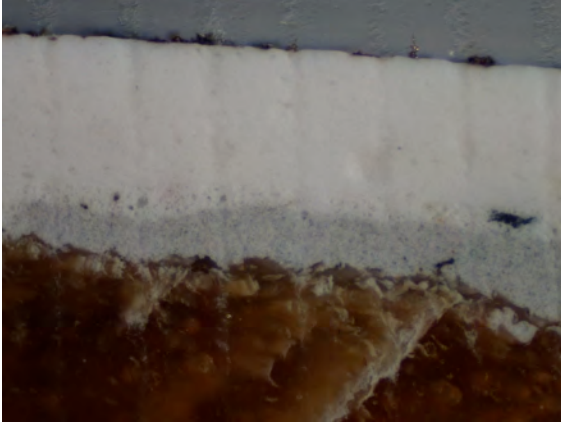

Visible light, 200x

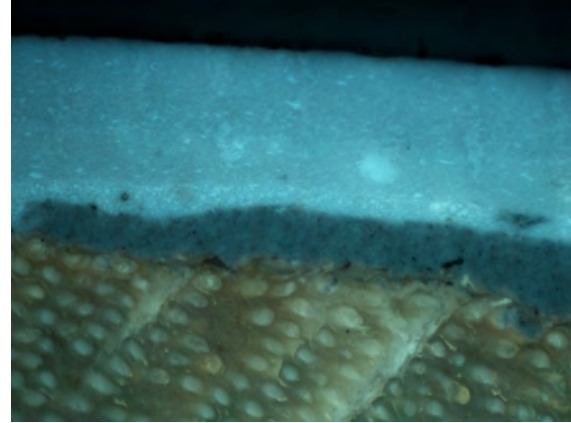

UV light, 200x

SAMPLE NO:	CALO.I.18
LOCATION:	Service Level, door frame at entry to second floor level

LAYER*	COLOR (VL)	COLOR (UV)	NOTES
Substrate	Wood		Stripped surface
1	Blue-gray	Gray	
2	White	Bright blue-green	Thin
3	White	Blue-green	Thick
4			
5			
6			
7			
8			
9			
10			
11			

***bold** indicates a finish layer

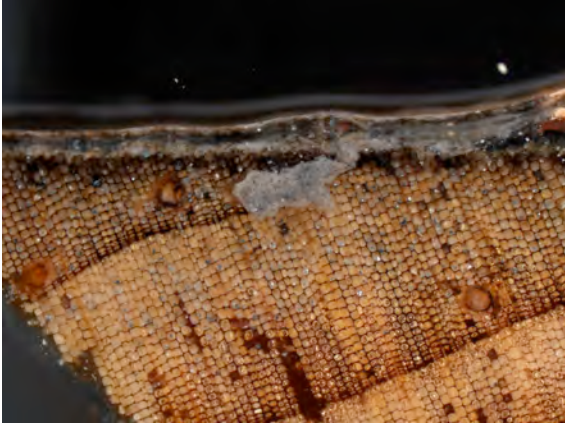

Visible light, 40x (Part A)



Visible light, 40x (Part B)

SAMPLE NO:	CALO.I.20
LOCATION:	Wood Stair Landing, Floor.

LAYER*	COLOR (VL)	COLOR (UV)	NOTES
Substrate	Wood		
1	Warm gray		
2	Res. brown		
3	White		
4	Red-orange		
5	Gray		
6	Black		
7	Red-orange		
8	Red-orange		
9	Red-orange		
10	Peach		
11	Red-orange		
12	Black		
13	Brown		

***bold** indicates a finish layer



Visible light, 40x

SAMPLE NO:	CALO.I.21
LOCATION:	Wood Stair Landing, Brick Window Well Floor.

LAYER*	COLOR (VL)	COLOR (UV)	NOTES
Substrate	Brick		
1	Red-brown		
2	Red-brown		
3	Black		
4	Black		
5	Black		
6	Black		
7	Off-white		limewash
8	Off-white		limewash
9	White		

***bold** indicates a finish layer

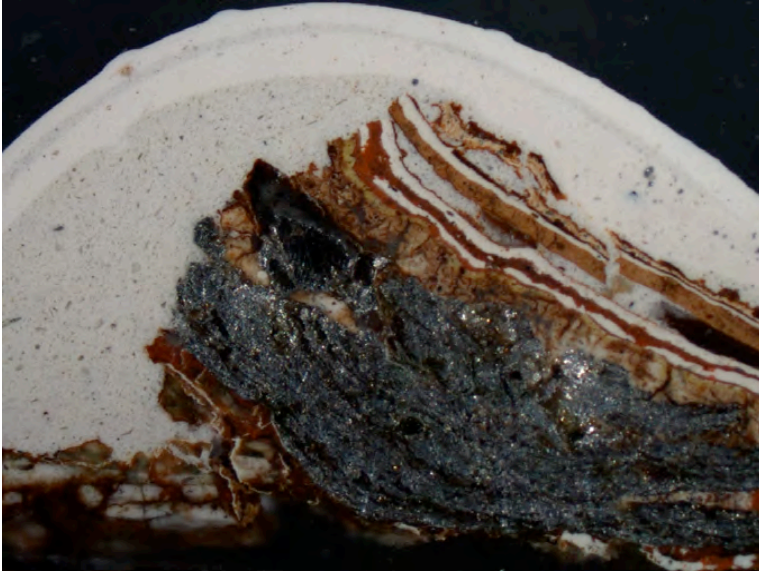

Visible light, 40x

SAMPLE NO:	CALO.I.22
LOCATION:	Lantern, bronze frame piece.

LAYER*	COLOR (VL)	COLOR (UV)	NOTES
Substrate			
1	Red-orange		
2	Cream		
3	Cream		
4	Silver		thick
5	Cream		
6	Yellow-green		
7	Orange		
8	White		
9	Orange		
10	White		
11	Orange		
12	White		
13	Salmon		
14	White		
15	White		
16	Red-orange		
17	White		
18	White		
19	White		

***bold** indicates a finish layer

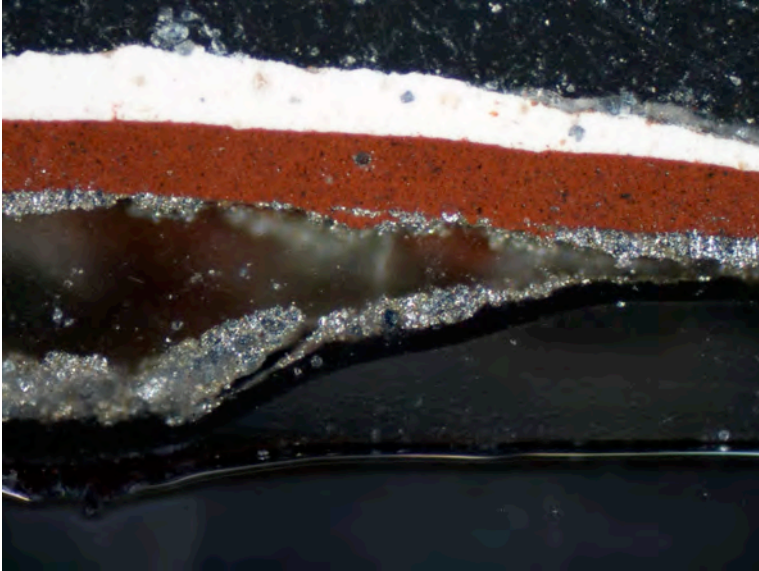

Visible light, 100x

SAMPLE NO:	CALO.I.23
LOCATION:	Interior hand rail

LAYER*	COLOR (VL)	COLOR (UV)	NOTES
Substrate			
1	White		
2	Red		
3	Green		
4	Silver		
5	White		
6	Black		
7	Black		

***bold** indicates a finish layer



Visible light, 40x

SAMPLE NO:	CALO.SALV.I
LOCATION:	Salvaged interior window sash, interior face.

LAYER*	COLOR (VL)	COLOR (UV)	NOTES
Substrate	Wood		
1	White		
2	White		
3	White		
4	White		
5	White		
6	White		
7	Light Gray		
8	White		
9	Off-White		grayish

***bold** indicates a finish layer

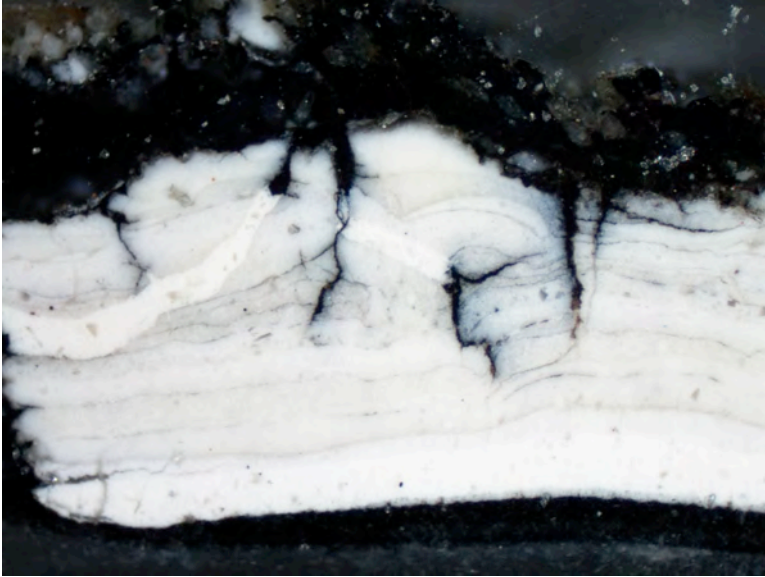

Visible light, 100x

SAMPLE NO:	CALO.SALV.2
LOCATION:	Salvaged interior window sash, exterior face (black)

LAYER*	COLOR (VL)	COLOR (UV)	NOTES
Substrate	None		
1	White		
2	White		
3	White		
4	White		
5	White		
6	White		
7	White		
8	White		
9	White		
10	Black		Leaked down through earlier layers
11	Black		

***bold** indicates a finish layer

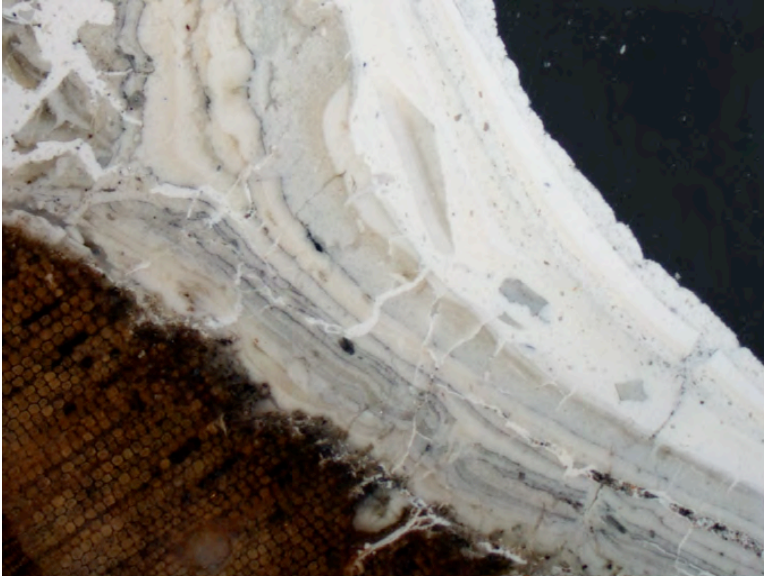

Visible light, 40x

SAMPLE NO:	CALO.SALV.3
LOCATION:	Salvaged interior window sash, exterior face (white)

LAYER*	COLOR (VL)	COLOR (UV)	NOTES
Substrate	None		
1	White		Creamy
2	White		Grayish
3	White		Grayish
4	White		Grayish
5	White		Creamy
6	White		
7	White		Creamy
8	White		Creamy
9	White		
10	White		
11	White		Grayish
12	White		
13	White		
14	White		Creamy
15	White		
16	White		
17	White		
18	White		
19	White		

***bold** indicates a finish layer



Visible light, 100x

SAMPLE NO:	CALO.SALV.4
LOCATION:	Salvaged interior door, stile

LAYER*	COLOR (VL)	COLOR (UV)	NOTES
Substrate	None		
1	Light khaki/warm gray		
2	White		
3	White		
4	White		
5	White		
6	White		
7	White		
8	White		
9	Gray		
10	White		

***bold** indicates a finish layer

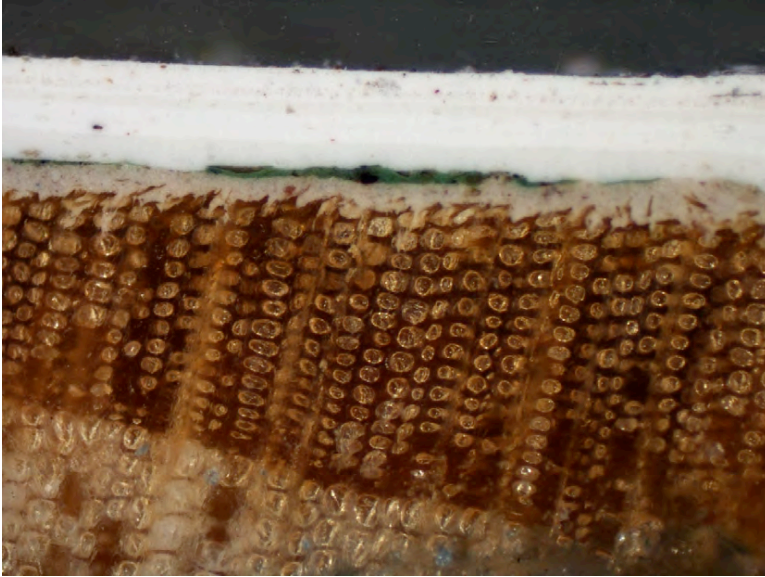

Visible light, 100x

SAMPLE NO:	CALO.SALV.5
LOCATION:	Salvaged interior door, panel

LAYER*	COLOR (VL)	COLOR (UV)	NOTES
Substrate	None		
1	Light khaki/warm gray		
2	Dark kelly green		
3	White		
4	White		
5	White		
6	White		
7	White		
8	White		
9	White		

***bold** indicates a finish layer



Visible light, 100x

SAMPLE NO:	CALO.SALV.6
LOCATION:	Salvaged interior door frame

LAYER*	COLOR (VL)	COLOR (UV)	NOTES
Substrate	None		
1	White		
2	White		
3	White		
4	White		Grayish
5	White		Creamy
6	White		
7	White		
8	White		
9	White		
10	White		
11	White		Grayish
12	White		
13	White		
14	White		
15	White		
16	White		
17	White		
18	White		
19	White		

***bold** indicates a finish layer



Visible light, 40x

SAMPLE NO:	CALO.SALV.7
LOCATION:	Salvaged interior beadboard wall

LAYER*	COLOR (VL)	COLOR (UV)	NOTES
Substrate	None		
1	Khaki		
2	Dark gray		brownish
3	Blue-gray		
4	Medium gray		
5	Medium gray		
6	Blue-gray		
7	Dark gray		
8	White		
9	White		
10	White		
11	White		
12	White		
13	White		
14	White		
15	White		
16	White		
17	White		
18	White		
19	White		
20	White		
21	White		
22	White		

***bold** indicates a finish layer

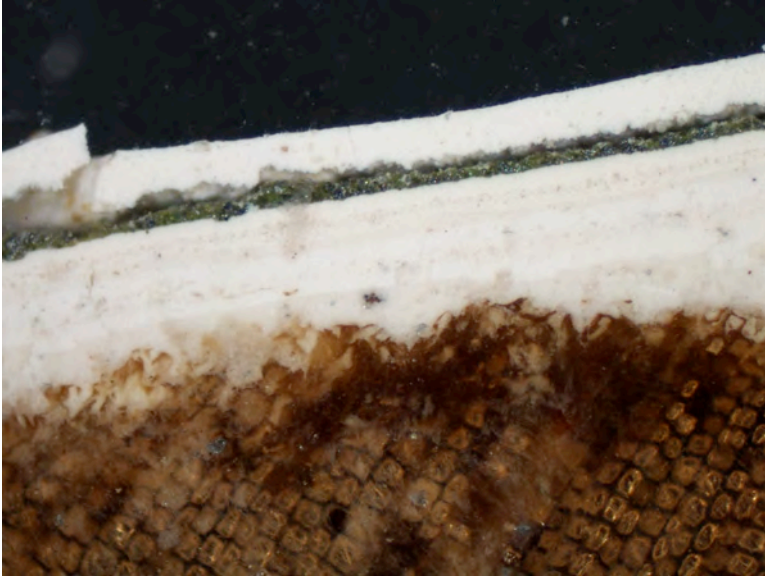

Visible light, 100x

SAMPLE NO:	CALO.SALV.9
LOCATION:	Salvaged interior door, unknown location

LAYER*	COLOR (VL)	COLOR (UV)	NOTES
Substrate	Wood		
1	White		
2	White		
3	White		
4	White		
5	White		
6	White		
7	Green		metallic
8	White		

***bold** indicates a finish layer

APPENDIX C.
MORTAR ANALYSIS REPORT
(TESTWELL, INC. 2008)

1. Introduction

On September 29, 2008, Testwell received two mortar samples from Ms. Dorothy Krotzer of Building Conservation Associates, Inc. reported to have been sampled from the Cape Lookout Lighthouse in North Carolina. The samples are identified as follows:

CALO.Mortar.1: Watch level observation deck

CALO.Mortar.2: Interior first floor space of the ground level, lower portion of the west wall.

At the client's request, comprehensive mortar analysis is performed on both samples. The comprehensive testing includes petrographic examination combined with chemical analysis to identify all binder and sand components and provide an estimate of the original binder to sand ratio. Additionally, a separation, gradation and description of the sand is requested with return of the recovered aggregate sample to the client.

2. Methods of Examination

The petrographic examination is conducted in accordance with the standard practices contained within *ASTM C1324: Standard Test Method for Examination and Analysis of Hardened Masonry Mortar*. Data collection is performed by a degreed geologist who by nature of his/her education is qualified to operate the analytical equipment employed. Analysis and interpretation is performed or directed by a supervising petrographer who satisfies the qualifications as specified in Section 3 of *ASTM C856*.

Chemical analysis was conducted according to the procedures outlined in *ASTM C1324: Standard Test Method for Examination and Analysis of Hardened Masonry Mortar*. Water, carbon dioxide and aggregate weight percentages are determined gravimetrically. Oxide weight percentages are determined by atomic absorption spectroscopy.

3. Petrographic Findings

SAMPLE ID**CALO.Mortar.1****GENERAL APPEARANCE**

Sample Type Several medium-sized, irregular mortar samples with a combined weight of 205.8 g.
Surfaces Surfaces are not obvious in the irregular samples though some minor residues of adherent brick are observed.
Hardness / Friability Moderately hard and non-friable.
Appearance Freshly exposed surfaces have a dull luster and are grayish brown in color (Munsell color code approximately 10YR 5/2).
Other Details No cracks, efflorescence, or other secondary mineral deposits are detected in hand sample. No obvious binder grains are visible.

AGGREGATE

Lithology and Mode Siliceous natural sand. The aggregate consists predominantly of quartz with traces of carbonate shell fragments, feldspar, and amphibolite.
Appearance The aggregate is a uniform, moderately bright lustered, sand with a light brownish gray color (Munsell color code approximately 10YR 6.5/1.5). Traces of coal dust are found in the sand recovery but these likely represent contaminants from the binder.
Size and Gradation The sand is fine-grained with a nominal top size measured at the No. 16 sieve. The aggregate is narrowly graded with most material falling between the No. 30 and No. 100 sieve sizes. Fines are present in minor abundance.
Shape Rounded to subrounded in shape. Subequant in aspect ratio on average.
Distribution Homogeneous and randomly oriented. Individual grains are separated from one another with a significant amount of binder. There is a good filling of sand interstices and no significant point contacts between grains.
Other No cracking, coatings, or chemical reactions are detected.

BINDER MATRIX

Hardened Binder Homogeneous hydraulic matrix with moderate to moderately high capillary porosity.
Residual Hydraulic Binder Natural cement relicts are found in high abundance as variously sized grains with internal textures consistent with the calcination of an argillaceous, dolomitic limestone.
Residual Lime Binder Relict lime grains are not identified.
Residual Pozzolans None detected.
Pigments None detected.

AIR-VOID SYSTEM

Estimated Air Content 12 - 15%
Consolidation / Distribution The mortar is well consolidated and the air distribution is homogeneous.
Size / Shape Voids are generally less than 1 mm in dimension. Voids are homogeneously distributed and mostly subspherical in shape.
Secondary Deposits No significant secondary deposits are detected.

AGGREGATE INTERFACES

Details Sand grains are well coated with binder. Bonds are hard and aggregate grains not easily dislodged from the matrix. No hydration variations, cracking or significant secondary mineral deposits are found at aggregate interfaces.

SECONDARY REACTIONS

Carbonation The outer several millimeters of the sample is fully carbonated along most edges while the interior is partially carbonated.
Other A somewhat continuous veneer of paste exhibiting textures consistent with acidic leaching is found around most edges of the sample. No other secondary mineral deposits are detected.

CRACKING

Details No significant microscopic or macroscopic cracking is observed.

SAMPLE ID**CALO.Mortar.2****GENERAL APPEARANCE**

Sample Type

Many small-sized, irregular mortar fragments with a combined weight of 70.6 g. Several small brick fragments are included in the sample.

Surfaces

Surfaces are not obvious in the irregular samples.

Hardness / Friability

Moderately soft and non-friable.

Appearance

Freshly exposed surfaces have a dull luster and are light gray in color (Munsell color code approximately 2.5Y 7/2).

Other Details

No cracks, efflorescence, or other secondary mineral deposits are detected in hand sample. No obvious binder grains are visible.

AGGREGATE

Lithology and Mode

Siliceous natural sand. The aggregate consists predominantly of quartz with traces of carbonate shell fragments, feldspar, and amphibolite.

Appearance

The aggregate is a uniform, moderately bright lustered, sand with a light brownish gray color (Munsell color code approximately 10YR 6.5/1.5). Traces of coal dust are found in the sand recovery but these likely represent contaminants from the binder.

Size and Gradation

The sand is fine-grained with a nominal top size measured at the No. 30 sieve. The aggregate is narrowly graded with most material falling between the No. 30 and No. 100 sieve sizes. Fines are present in minor abundance.

Shape

Rounded to subrounded in shape. Subequant in aspect ratio on average.

Distribution

Homogeneous and randomly oriented. Individual grains are separated from one another with a significant amount of binder. There is a good filling of sand interstices and no significant point contacts between grains.

Other

No cracking, coatings, or chemical reactions are detected.

BINDER MATRIX

Hardened Binder

Homogeneous hydraulic matrix with moderate to moderately high capillary porosity.

Residual Hydraulic Binder

Natural cement relicts are found in high abundance as variously sized grains with internal textures consistent with the calcination of an argillaceous, dolomitic limestone.

Residual Lime Binder

Relict lime grains are not identified.

Residual Pozzolans

None detected.

Pigments

None detected.

AIR-VOID SYSTEM

Estimated Air Content

8 - 10%

Consolidation / Distribution

The mortar is well consolidated and the air distribution is homogeneous.

Size / Shape

Voids are generally less than 1 mm in dimension. Voids are homogeneously distributed and mostly subspherical in shape.

Secondary Deposits

Secondary carbonate is found in many of the air-voids.

AGGREGATE INTERFACES

Details

Sand grains are well coated with binder. Bonds are moderate and aggregate grains relatively easy to dislodge from the matrix. No hydration variations, cracking or significant secondary mineral deposits are found at aggregate interfaces.

SECONDARY REACTIONS

Carbonation

The cementitious paste is mostly carbonated throughout.

Other

No other secondary mineral deposits are detected. However, smaller air-voids tend to be filled with fine recrystallized carbonate while larger voids are lined by the same type of deposit.

CRACKING

Details

No significant microscopic or macroscopic cracking is observed.

4. Aggregate Sieve Analysis

Aggregate analysis is performed by digesting the mortar sample in an appropriate acid sufficient to dissolve the binder. Recovered fines are examined petrographically in order to determine whether they represent undigested binder components in which case the data are adjusted accordingly. Qualitative descriptions of the sands are given in the petrographic tables above and the recovered samples are provided with this report. It should be understood that the sample size is significantly smaller than would be required to perform a sieve analysis on fresh aggregate materials as per ASTM C136 and some small errors should be expected.

Table 4.1: Raw Data

<i>SAMPLE ID</i>	CALO.Mortar.1	CALO.Mortar.2
Sieve Retention (g)		
No. 4	0.00	0.00
No. 8	0.00	0.00
No. 16	0.06	0.00
No. 30	1.08	0.16
No. 50	15.17	3.93
No. 100	26.89	7.08
No. 200	1.28	0.30
Pan	0.30	0.06

Table 4.2: Cumulative Percent Passing

<i>SAMPLE ID</i>	CALO.Mortar.1	CALO.Mortar.2
Cumulative Passing		
No. 4	100.0	100.0
No. 8	100.0	100.0
No. 16	99.9	100.0
No. 30	97.5	98.6
No. 50	63.6	64.5
No. 100	3.5	3.1
No. 200	0.7	0.5

Table 4.3: Cumulative Percent Retained

<i>SAMPLE ID</i>	CALO.Mortar.1	CALO.Mortar.2
Cumulative Retained		
No. 4	0.0	0.0
No. 8	0.0	0.0
No. 16	0.1	0.0
No. 30	2.5	1.4
No. 50	36.4	35.5
No. 100	96.5	96.9
No. 200	99.3	99.5
Fineness Modulus	1.36	1.34

5. Chemical Analyses

Table 5.1: Chemical Analysis Results

<i>SAMPLE ID</i>	CALO.Mortar.1	CALO.Mortar.2
Component (wt. %)		
SiO ₂ (acid soluble)	7.29	8.13
CaO	11.01	15.74
MgO	7.10	5.58
Al ₂ O ₃	1.19	1.35
Fe ₂ O ₃	1.06	0.72
Modified insoluble residue	51.34	47.61
LOI %, to 110°C (Free water)	4.45	2.59
LOI %, 110°C-550°C (Combined water)	7.00	5.17
LOI %, 550°C-950°C (Carbon dioxide)	6.64	10.62
Measured Totals	97.07	97.52

Notes:

- 1) Our experience indicates that the normal acid insoluble residue performed on natural cement mortars results in significant overages due to the inclusion of amorphous silica from the cement binder included in the residue. This interference is overcome by treating the residue with a second alkaline digestion to remove this component.

Table 5.2: Estimated Original Cement Chemistries

<i>SAMPLE ID</i>	CALO.Mortar.1	CALO.Mortar.2
Component (wt. %)		
SiO ₂ (acid soluble)	25.1	24.5
CaO	37.8	47.4
MgO	24.4	16.8
Al ₂ O ₃	4.08	4.07
Fe ₂ O ₃	3.64	2.18
Other	5.0	5.0
Total	100	100
CaO/MgO Ratio	1.55	2.82
Cementation Index	1.07	1.05

Notes:

- 1) As only one binder type was identified in each sample, it was possible to estimate the original chemistry of each by normalizing the measured oxide values to the percentage for which these oxides are estimated to be present in the original material (i.e., approximately 95%). The CaO/MgO ratio is calculated as a simple quotient. Cementation index is calculated by converting each measured oxide to its molecular equivalent weight to calcium, summing the hydraulic equivalents (SiO₂, Al₂O₃, and Fe₂O₃) and dividing by the sum of the lime-type equivalents (CaO and MgO). This index may be used in assessing the nature of the binder.

Table 5.3: Calculated Components

<i>SAMPLE ID</i>	CALO.Mortar.1	CALO.Mortar.2
Component		
Portland cement (wt. %)	Not detected	Not detected
Masonry cement (wt. %)	Not detected	Not detected
Natural cement (wt. %)	36	41
Lime expressed as dry hydrate (wt. %)	Not detected	Not detected
Hydraulic lime (wt. %)	Not detected	Not detected
Ground limestone (wt. %)	Not detected	Not detected
Pozzolans (wt. %)	Not detected	Not detected
Mineral Pigment (wt. %)	Not detected	Not detected
Sand (wt. %)	64	59
Binder : sand ratio (by volume)	1 : 1.6	1 : 1.3

Notes:

- 1) Cement weight is calculated by assuming all five oxides represent 95% of the binder portion and the total weight adjusted accordingly. The sand weight is taken directly from the modified insoluble residue. Both values are then normalized to 100%. Component volume ratios are calculated assuming typical bulk densities of 75 lb./cu. ft. and 80 lb./cu. ft. for natural cement and sand in damp, loose condition respectively.

6. Discussion and Conclusions

Both samples are determined to represent natural cement mortars. The identification is certain for Sample CALO.Mortar.1 based on hand sample properties, microscopy, and chemistry. There was some question as to whether there could be a lime component in Sample CALO.Mortar.2 given the softness and friability as well as the higher calcium content measured chemically. However, there is no petrographic evidence to suggest that any lime was included in this mortar sample.

The cement in both samples is identified petrographically as a natural cement produced by the low temperature calcination of an impure dolomitic or magnesian limestone. High magnesium values measured chemically clearly indicate a typical American rather than European cement. The exact provenance of the cement cannot be determined. However, the chemistry is at least consistent with cements produced in northwestern Georgia during the latter half of the nineteenth century. Given the proximity to North Carolina, this is a possible source. The binder chemistries are compared by normalizing the measured oxides to an equivalent value (Table 5.2). What is notable here is that the ratio of the hydraulic elements (silica, alumina, and iron) are quite similar. However, the calcium to magnesium ratio is higher in Sample CALO.Mortar.2 than Sample CALO.Mortar.1. This could be interpreted to represent a lime component in the former. It is possible to subtract enough calcium to explain a lime component of approximately one quarter of the cement by volume and still have a resultant chemistry typical of a natural cement. However, the resultant cement chemistries are no longer similar. Moreover, there is no petrographic evidence of a lime addition. The chemical disparity is considered by the author to represent some significant variation in the carbonate component of the cement rock and high chemical variation is typical of American natural cements. The petrographic evidence suggests that the cements are from a similar source and they may even represent the same vintage. This would indicate a cement of variable quality and may explain the softer quality of the binder in Sample CALO.Mortar.2.

The sand in both samples is a fine-grained and bright-lustered aggregate characterized as a siliceous natural sand. The color is a uniform light brownish gray. Traces of dark colored coal dust in the recovered aggregate are interpreted to represent a contaminant from the binder. The sand consists predominantly of quartz with traces of fine shell fragments and heavy minerals. Grain shapes are soft being mostly rounded to subrounded. The gradation is narrow with a vast majority of material found between the No. 30 and No. 100 sieve sizes. The sand has a nominal top size at the No. 16 and No. 30 sieve for Samples CALO.Mortar.1 and CALO.Mortar.2 respectively. Nevertheless, the sands are considered virtually identical in both samples. The softness, narrow gradation, and mineralogy of the sand are all consistent with a well-sorted and mature beach sand. Details of the gradation may be found in Section 4 above. Recovered sand samples are provided with this report.

Chemical analysis was performed on both samples in order to estimate material proportions and details of the calculations are given in the notes of Section 5 above. As discussed above, both samples are considered pure cement mortars and proportional estimations are given accordingly. The binder to sand ratios by volume are estimated at 1 : 1.6 and 1 : 1.3 for Samples CALO.Mortar.1 and CALO.Mortar.2 respectively. While these may be considered quite undersanded by contemporary standards, it should be understood that ratios between 1 : 1 and 1 : 2 are typical of and appropriate for nineteenth century natural cement mortars.

Both samples exhibit typical carbonation. Other minor chemical reactions are detected within no associated distress. Exterior portions of Sample CALO.Mortar.1 exhibit a thin veneer of weathered paste consistent in texture with minor acidic leaching of soluble cement phases. Sample CALO.Mortar.2 contains abundant calcium carbonate deposits in air-voids but no cracking nor evidence for significant paste deterioration.

TESTWELL, INC.

John J. Walsh
Senior Petrographer/ Geologist

Samples will be discarded 30 days after the final report date unless otherwise instructed. This report is the confidential property of the client and any unauthorized reproduction is strictly prohibited. The interpretations and conclusions presented in this report are based on the samples provided.

Appendix I: Photographs and Photomicrographs

Microscopic examination is performed on an Olympus BX-51 polarized/reflected light microscope and a Bausch and Lomb Stereozoom 7 stereoscopic reflected light microscope. Both microscopes are fitted with an Olympus DP-11 digital camera. The overlays presented in the photomicrographs (e.g., text, scale bars, and arrows) are prepared as layers in Adobe Photoshop and converted to the jpeg format. Digital processing is limited to those functions normally performed during standard print photography processing. Photographs intended to be visually compared are taken under the same exposure conditions whenever possible.

The following abbreviations may be found in the figure captions and overlays and these are defined as follows:

cm	centimeters	PPL	Plane polarized light
mm	millimeters	XPL	Crossed polarized light
µm	microns (1 micron = 1/1000 millimeter)		
mil	1/1000 inch		

Microscopical images are often confusing and non-intuitive to those not accustomed to the techniques employed. The following is offered as a brief explanation of the various views encountered in order that the reader may gain a better appreciation of what is being described.

Reflected light images: These are simply magnified images of the surface as would be observed by the human eye. A variety of surface preparations may be employed including polished and fractured surfaces. The reader should note the included scale bars as minor deficiencies may seem much more significant when magnified.

Plane polarized light images (PPL): This imaging technique is most often employed in order to discern textural relationships and microstructure. To employ this technique, samples are milled (anywhere from 20 to 30 microns depending on the purpose) so as to allow light to be transmitted through the material. In many cases, TLI also employs a technique whereby the material is impregnated with a low viscosity, blue-dyed epoxy. Anything appearing blue therefore represents some type of void space (e.g.; air voids, capillary pores, open cracks, etc.) Hydrated cement paste typically appears a light shade of brown in this view (with a blue hue when impregnated with the epoxy). With some exceptions, most aggregate materials are very light colored if not altogether white. Some particles will appear to stand out in higher relief than others. This is a function of the refractive power of different materials with respect to the mounting epoxy.

Crossed polarized light images (XPL): This imaging technique is most often employed to distinguish components or highlight textural relationships between certain components not easily distinguished in plane polarized light. Using the same thin sections, this technique places the sample between two pieces of polarizing film in order to determine the crystal structure of the materials under consideration. Isotropic materials (e.g.; hydrated cement paste, pozzolans and other glasses, many oxides, etc.) will not transmit light under crossed polars and therefore appear black. Non-isotropic crystals (e.g.; residual cement, calcium hydroxide, calcium carbonate, and most aggregate minerals) will appear colored. The colors are a function of the thickness, crystal structure, and orientation of the mineral. Many minerals will exhibit a range of colors due to their orientation in the section. For example, quartz sand in the aggregate will appear black to white and every shade of gray in between. Color difference does not necessarily indicate a material difference. When no other prompt is given in the figure caption, the reader should appeal to general shapes and morphological characteristics when considering the components being illustrated.

Chemical treatments: Many chemical techniques (etches and stains typically) are used to isolate and enhance a variety of materials and structures. These techniques will often produce strongly colored images that distinguish components or chemical conditions.



Figure 1: Mortar samples CALO.Mortar.1 (top) and CALO.Mortar.2 (bottom) received by Testwell for comprehensive analysis.

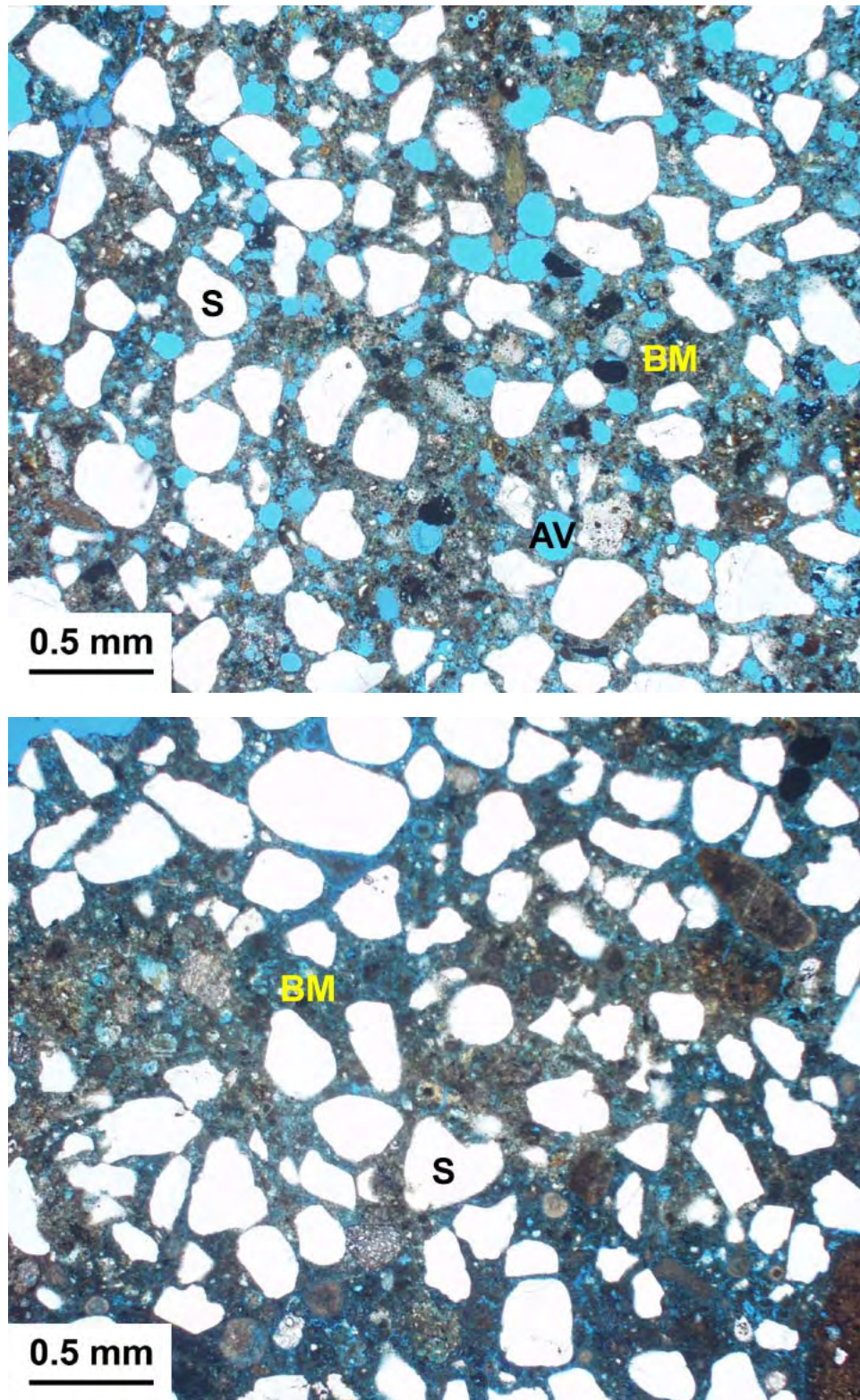

Figure 2: PPL photomicrographs illustrating the microtexture of mortar samples CALO.Mortar.1 (top) and CALO.Mortar.2 (bottom). Relatively rounded and narrowly graded sand grains (S) are well distributed throughout the binder matrix (BM). The cementitious matrix has a moderate capillary porosity as indicated by the blue-dyed epoxy used in the sample preparation. Air-voids (AV) are shown for sample CALO.Mortar.1 and these are abundant. Voids are nearly as abundant in sample CALO.Mortar.2 but are mostly filled with secondary calcium carbonate rendering them nearly invisible at this scale (see Figure 6).

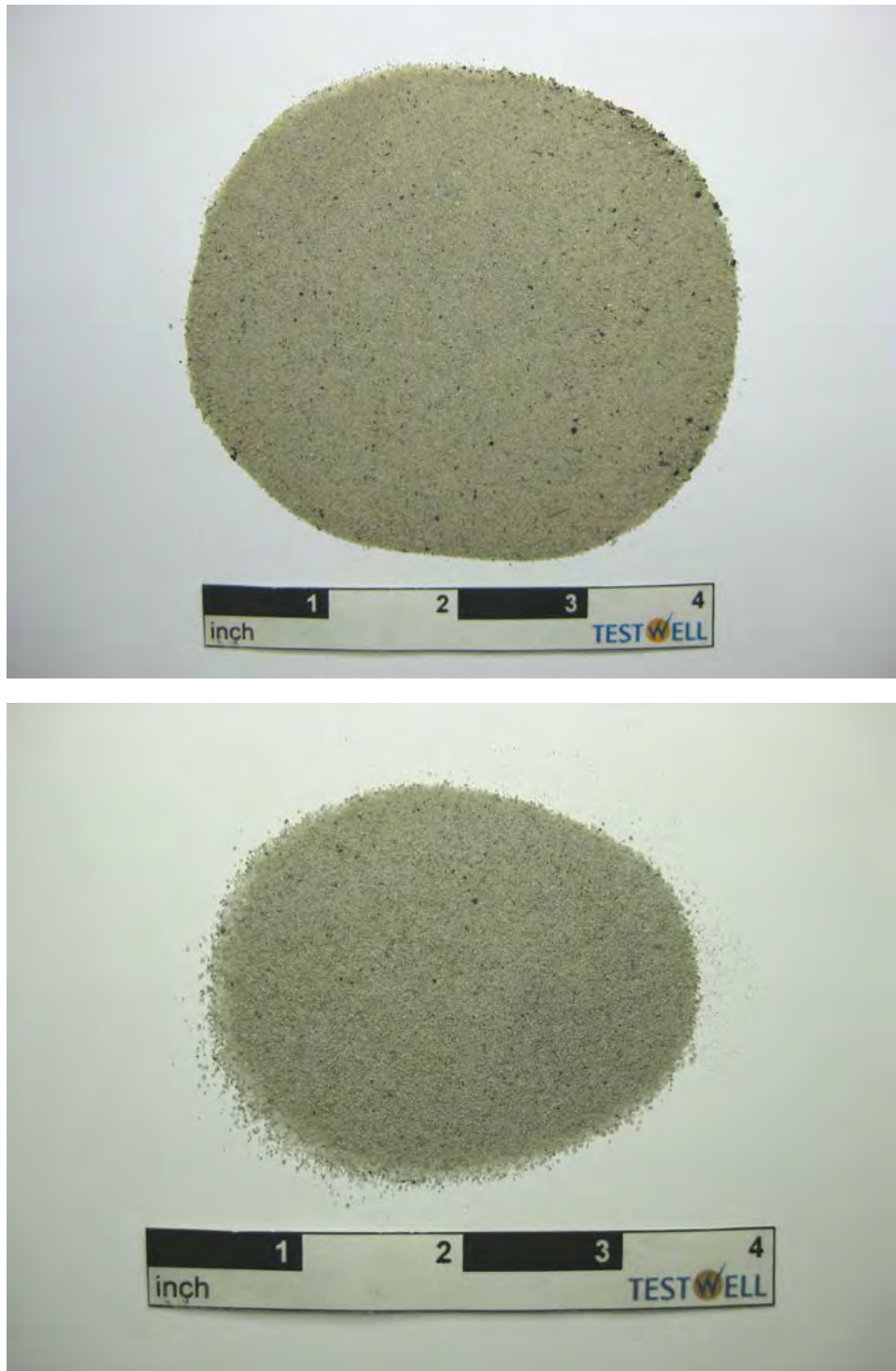

Figure 3: Photographs of sand separated from mortar samples CALO.Mortar.1 (top) and CALO.Mortar.2 (bottom). The sands are virtually identical appearing as uniform, fine-grained, and light-colored sands. The trace dark grains are identified as coal dust that likely represent a minor contaminant from the cement.

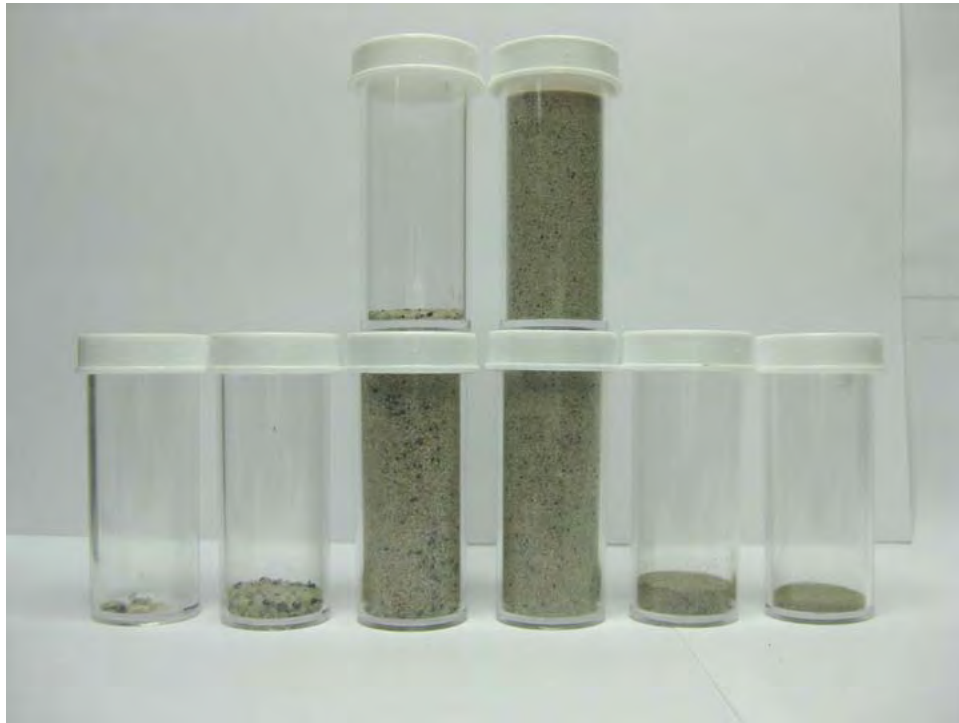

Figure 4: Photographs of the graded sand separated from mortar samples CALO.Mortar.1 (top) and CALO.Mortar.2 (bottom). The sands are both narrowly graded with a vast majority of material found between the No. 30 and No. 100 sieves.

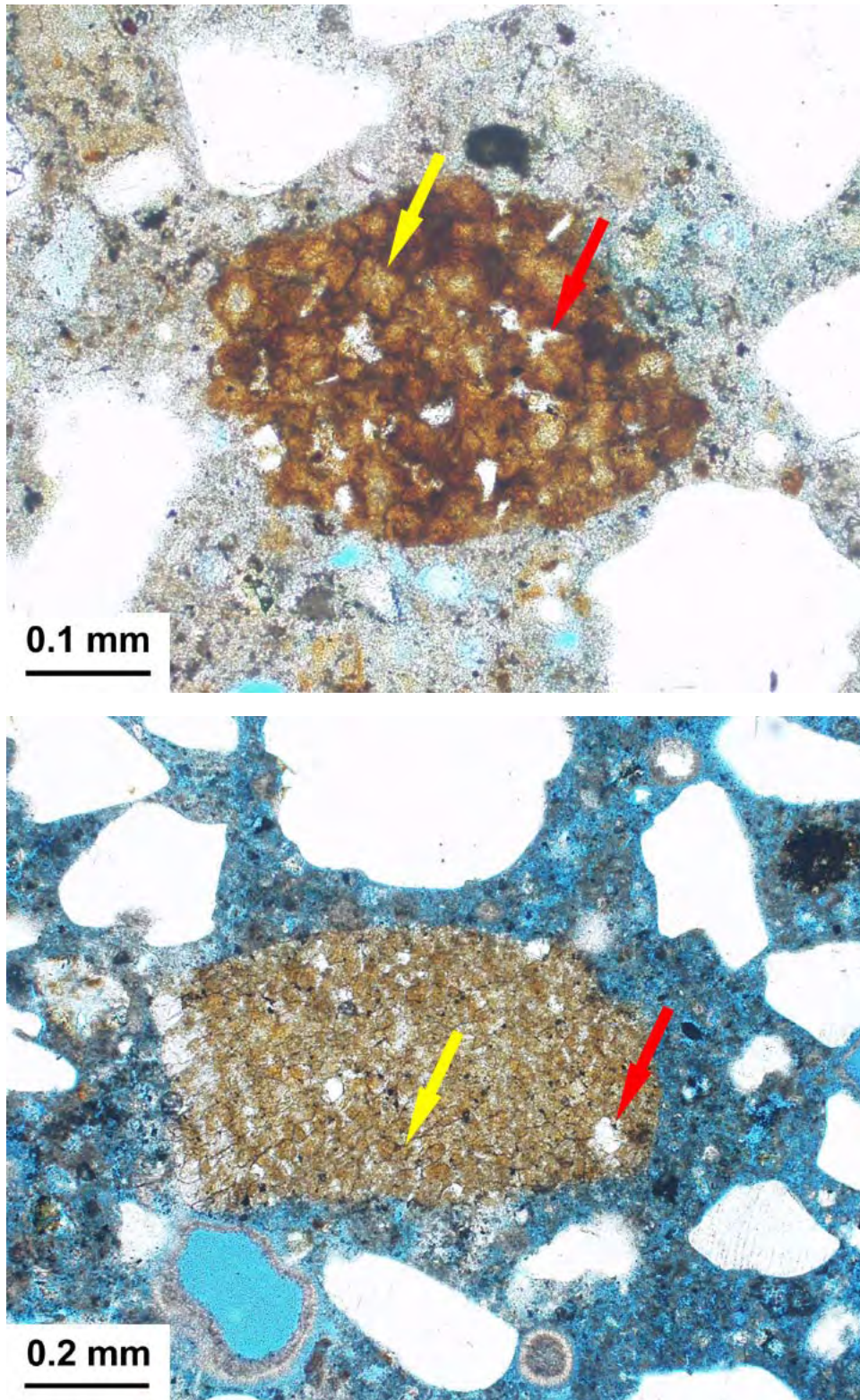

Figure 5: PPL photomicrographs illustrating natural cement grains in mortar samples CALO.Mortar.1 (top) and CALO.Mortar.2 (bottom). The yellow arrows indicate original dolomite crystals now lined with iron-bearing cement phases. The red arrows represent quartz silt grains that have not combined during cement calcination. These textures are typical of nineteenth century American natural cements. No residual lime binder is detected petrographically in either sample.

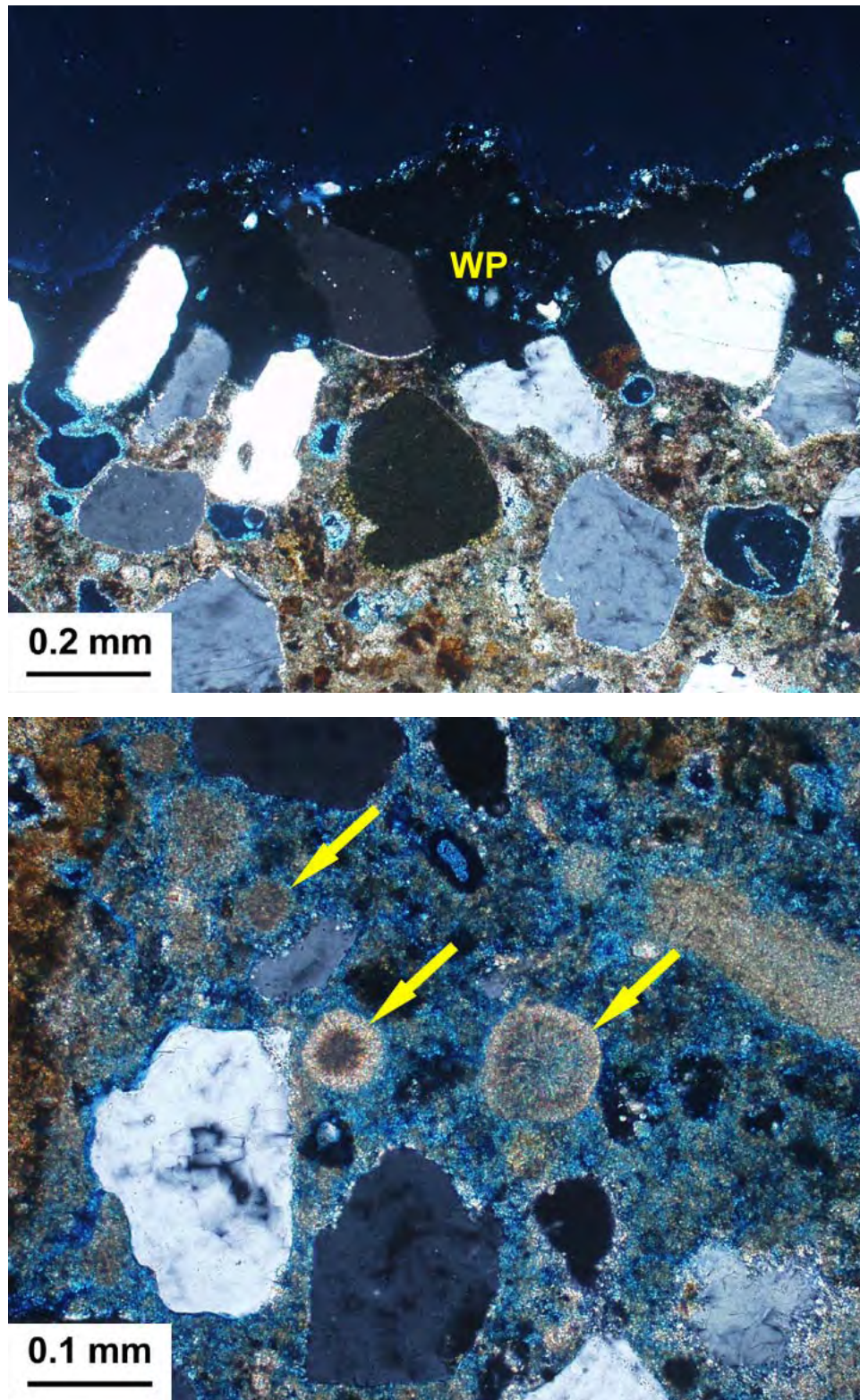

Figure 6: XPL photomicrographs illustrating minor secondary chemical reactions. (Top) Sample CALO.Mortar.1 exhibits a rind of weathered paste (WP). The golden color of the paste below is due to normal carbonation. The dark color within the rind indicates dissolution of this secondary carbonate along with other acid-soluble phases. The weathered paste is consistent in texture with that affected by acidic solution. (Bottom) The arrows indicate air-voids in Sample CALO.Mortar.2 that are filled with secondary calcium carbonate. These are visible in hand sample as fine white spots that should not be confused with lime inclusions.

APPENDIX D.
BRICK ANALYSIS REPORT
(CTL GROUP 2008)



**CONSTRUCTION
TECHNOLOGY LABORATORIES
ENGINEERS & CONSTRUCTION
TECHNOLOGY CONSULTANTS**

November 19, 2008

www.CTLGroup.com

Ms. Dorothy Krotzer
Building Conservation Associates
329 Race Street
Philadelphia, PA 19106

Via e-mail
email: dkrotzer@bcausa.com
Phone: 215-923-2834
Fax: 215-923-2835

**Test Results for ASTM C 67 Brick Testing
Cape Lookout Lighthouse
CTLGroup Project No. 390783**

Dear Ms. Krotzer:

Attached are the referenced test results for the six samples which you submitted and identified that arrived at CTLGroup on October 31, 2008. The concrete bricks were identified as Calo. Brick 1, Calo. Brick 2, Calo. Brick 3, Calo. Brick 4, Calo. Brick 5 and Calo. Brick 6. Four bricks were selected based on their ability to be handled and prepared for testing.

As requested, testing was performed in accordance with ASTM C 67 – 07, "Standard Test Methods for Sampling and Testing Brick and Structural Clay Tile." The four selected brick specimens were cut in half in preparation for testing. Four brick halves were tested in compression and the other four were tested for absorption.

Compressive strength test results indicate that Calo. Brick 1 and Calo. Brick 5 test specimens exceed the minimum individual brick requirement for compressive strength, for Grade SW (severe weathering) and Grade MW (moderate weathering) as stated in Table 1 Physical Requirements of ASTM C 216 – 07, "Standard Specification for Facing Brick (Solid Masonry Units Made from Clay or Shale). Additionally, Calo. Brick 2 meets the individual brick requirement for Grade MW.

Absorption test results indicate the average absorption of the four brick test specimens is below the maximum average of the 5-hour boil absorption requirement for both Grade SW and Grade MW as stated in Table 1 Physical Requirements of ASTM C 216 – 07. Further, the test results meet (are below) the individual requirement for 5-hour boiling absorption, for Grade SW and Grade MW as stated in Table 1 Physical Requirements of ASTM C 216 – 07.

The saturation coefficient test results indicate the average of four test specimen bricks is below the maximum average requirement for Grade SW (severe weathering) and for Grade MW (moderate weathering) as stated in Table 1 Physical Requirements of ASTM C 216 – 07. Additionally, the average of four bricks meets the alternate 24 hour cold water absorption requirement of Section 6.1.2 Absorption Alternate of ASTM C 216 – 07 of 8%.

In conclusion, three of the tested samples meet the relevant compressive strength requirements for Grade MW and two meet the requirements of Grade SW. All of the tested samples meet the absorption requirements. Based on this testing, the brick may continue to be satisfactory for its intended use. However, if the cracking and spalling seen in the as-received samples are exhibited on the structure, further investigation may be warranted.

We will retain the remainder of these samples until December 31, 2008 at which time they will be discarded unless we hear otherwise from you.

We appreciate the opportunity to provide specialized testing for you. Should you have any questions, please contact us.

Sincerely,



Julia Johnson
Associate I
Materials Testing & Analysis
JJohnson@CTLGroup.com
Phone: (847) 972-3122

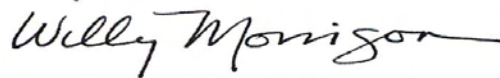

W. Morrison
Principal Materials Scientist
Materials Consulting
WMorrison@CTLGroup.com
Phone: (847) 972-3162

Attachments



Figure 1. As-received photos of "Calo. Brick 1" and "Calo. Brick 2"

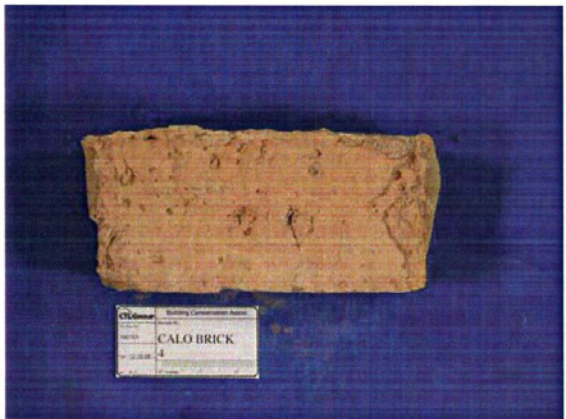

Figure 2. As-received photos of "Calo. Brick 3" and "Calo. Brick 4"

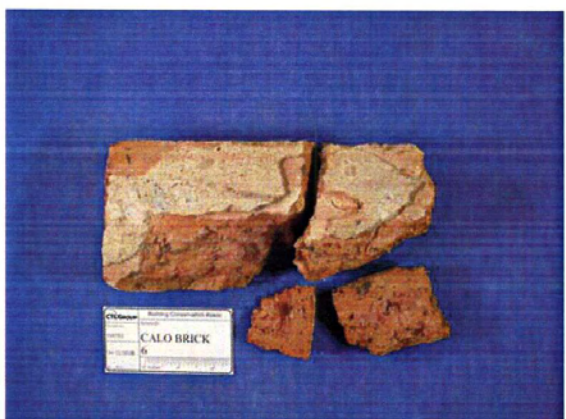

Figure 3. As-received photos of "Calo. Brick 5" and "Calo. Brick 6"



CONSTRUCTION
TECHNOLOGY LABORATORIES
ENGINEERS & CONSTRUCTION
TECHNOLOGY CONSULTANTS
www.CTLGroup.com

Client: Building Conservation Associates
Project: Cape Lookout Lighthouse Brick
Contact: Ms. Dorothy Krotzer
Submitter: Ms. Dorothy Krotzer

CTLGroup Proj. No: 390783
CTLGroup Proj. Mgr.: J. Johnson
Technician: F. Blaul/J. Johnson
Approved: W. Morrison
Date: November 19, 2008

ASTM C 67
Standard Test Methods for Sampling and Testing Brick and Structural Clay Tile

Compression Specimens

<u>Specimen Identification</u>	<u>As Received Weight (lb)</u>	<u>Oven Dry Weight (lb)</u>	<u>Avg. Width (in.)</u>	<u>Avg. Height (in.)</u>	<u>Avg. Length (in.)</u>
#1	1.71	1.71	3.55	2.07	3.56
#2	1.67	1.67	3.63	2.08	3.65
#4	1.73	1.72	3.61	2.15	3.61
#5	1.88	1.88	3.33	2.20	4.11
Average	1.75	1.74	3.53	2.13	3.73

<u>Specimen Identification</u>	<u>Avg. Gross Area (in²)</u>	<u>Maximum Load (lb)</u>	<u>Gross Area Compressive Strength (psi)</u>	<u>ASTM C 216-07 Requirements for Gross Area Compressive Strength</u>	
				<u>Grade SW (psi)</u>	<u>Grade MW (psi)</u>
#1	12.66	42,000	3,320	Min. 2500	Min. 2200
#2	13.25	32,800	2,480	Min. 2500	Min. 2200
#4	13.03	28,000	2,150	Min. 2500	Min. 2200
#5	13.68	40,200	2,940	Min. 2500	Min. 2200
Average	13.15	35,750	2,720	Min. 3000	Min. 2500

This report may not be reproduced except in its entirety.

Corporate Office: 5400 Old Orchard Road Skokie, Illinois 60077-1030 Phone 847-965-7500 Fax 847-965-6541
Washington D.C. Office: 9030 Red Branch Road, Suite 110, Columbia, Maryland 21045-2003 Phone 410-997-0400 Fax 410-997-8480



**CONSTRUCTION
TECHNOLOGY LABORATORIES**
**ENGINEERS & CONSTRUCTION
TECHNOLOGY CONSULTANTS**
www.CTLGroup.com

Client: Building Conservation Associates
Project: Cape Lookout Lighthouse Brick
Contact: Ms. Dorothy Krotzer
Submitter: Ms. Dorothy Krotzer

CTLGroup Proj. No: 390783
CTLGroup Proj. Mgr.: J. Johnson
Technician: F. Blaul/J. Johnson
Approved: W. Morrison
Date: November 19, 2008

ASTM C 67
Standard Test Methods for Sampling and Testing Brick and Structural Clay Tile

Absorption Specimens

<u>Specimen Identification</u>	<u>As Received Weight (lb)</u>	<u>5-hr. Cold Water Saturated Weight (lb)</u>	<u>24-hr. Cold Water Saturated Weight (lb)</u>	<u>5-hr. Boiling Water Saturated Weight (lb)</u>	<u>Oven Dry Weight (lb)</u>
#1	1.88	1.96	1.96	2.10	1.87
#2	1.12	1.24	1.24	1.32	1.12
#4	1.70	1.85	1.86	1.97	1.70
#5	1.38	1.47	1.47	1.56	1.38
Average	1.52	1.63	1.63	1.74	1.52

<u>Specimen Identification</u>	<u>5-hr. Cold Water Absorption (%)</u>	<u>5-hr. Boiling Water Absorption (%)</u>	ASTM C 216-07 Requirements for 5-hr. Boiling Water Absorption	
			<u>Grade SW (%)</u>	<u>Grade MW (%)</u>
#1	4.7%	11.9%	Max. 20.0%	Max. 25.0%
#2	10.4%	17.3%	Max. 20.0%	Max. 25.0%
#4	9.2%	16.0%	Max. 20.0%	Max. 25.0%
#5	6.4%	13.3%	Max. 20.0%	Max. 25.0%
Average	7.7%	14.7%	Max. 17.0%	Max. 22.0%

<u>Specimen Identification</u>	<u>24-hr. Cold Water Absorption (%)</u>	ASTM C 216-07 Requirements for 24-hr. Cold Water Absorption (%)	<u>Saturation Coefficient</u>	ASTM C 216-07 Requirements for Saturation Coefficient	
				<u>Grade SW</u>	<u>Grade MW</u>
#1	4.7%	-	0.40	Max. 0.80	Max. 0.90
#2	10.5%	-	0.61	Max. 0.80	Max. 0.90
#4	9.5%	-	0.59	Max. 0.80	Max. 0.90
#5	6.5%	-	0.49	Max. 0.80	Max. 0.90
Average	7.8%	Max. 8.0%	0.52	Max. 0.78	Max. 0.88

This report may not be reproduced except in its entirety.

APPENDIX E

Class C Construction Cost Estimate

Class C Construction Cost Estimate

Project: Cape Lookout Lighthouse

Park: Cape Lookout National Seashore

Package:

Assumption: Twelve-month Construction PeriodEstimate By: JKODate: 09.10.2008Reviewed By: RABDate: 10.07.2008**Estimate is Based on 2008 Costs**

Category/Item No.	Description	Quantity	Unit	Cost/Unit	Total
I. GENERAL CONDITIONS					
	A. Temporary Facilities				
	1. Emergency Generator	1	LS	\$2,500.00	\$2,500
	2. Fuel (Generator and Equipment Fuel)	365	day	\$150.00	\$54,750
	3. Porta-johns (2)	12	month	\$600.00	\$7,200
	B. Field Office				
	1. Building-Office	1	LS		\$3,000
	2. Reprigerator, Office Equipment and Furnishings	1	LS		\$4,000
	3. Emergency Supplies	1	LS		\$1,000
	4. Communication	12	month	\$500.00	\$6,000
	5. Office Supplies	12	month	\$300.00	\$3,600
	C. Foreman	52	week	\$1,800.00	\$86,400
	D. Allowances				
	1. Meals - Foreman	260	day	\$45.00	\$11,700
	2. Meals - Crew (6)	1560	day	\$35.00	\$54,600
	3. Lodging - Foreman	260	day	\$150.00	\$39,000
	4. Lodging - Crew (6)	1560	day	\$75.00	\$117,000
	D. Equipment				
	1. Interior Scaffolding	1	LS		\$44,000
	2. Exterior Scaffolding and Shroud	1	LS		\$200,000
	3. Engineerig Desgin for Scaffolding	1	LS		\$10,000
	4. Site Vehicles (2)	12	month	\$1,000.00	\$12,000
	5. Miscellaneous Equipment/Tools	52	week	\$200.00	\$26,000
	E. Fencing	1	LS		\$10,400
	F. Temporary Workshops (Paint, Carpentry, Metal Work, Lantern)	1	LS		\$12,000
	G. Other Expenses				
	1. Mobilization	1	LS		\$10,000
	2. Hoist	1	LS		\$10,000
	3. Barge and Boat (2)	12	month	\$1,000.00	\$12,000
	4. Boat Slip Rentals (2)	12	month	\$500.00	\$6,000
	5. Evening Security Guard	365	day	\$200.00	\$73,000
					\$816,150
II. DEMOLITION/DISPOSAL					
	A. Dismantle/Discard Steel Tube-and-angle Framing	1	LS	\$9,000.00	\$9,000

	B. Dismantle/Discard Steel Doorway Units (2)	2	unit	\$300.00	\$600
	C. Dismantle/Discard Electrical Service and Fixtures	1	LS		\$2,400
	D. Dismantle/Discard Cyclone Fence Room (Second Floor)	1	LS		\$600
	E. Strip/Capture Exterior Paint	8,500	sf	\$20.00	\$170,000
	F. Cut-out/ Remove Exterior/ Interior Mortar Joints	14,000	sf	\$25.00	\$350,000
	G. Dismantle/Discard Main Entrance Stairway	1	LS		\$2,000
	H. Remove Lantern and Gallery to On-site Workshop	1	LS		\$9,000
	I. Dismantle/Remove Iron Ring and Plate	1	LS		\$5,400
	J. Dismantle/Remove Pipe Railing from Watch Level Observation Deck	1	LS		\$1,800
	K. Remove Slurry from Granite Door/Window Lintels	13	intel	\$300.00	\$3,900
	L. Debris Removal	12	month	\$500.00	\$6,000
	M. Disposal of Hazardous Material	1	LS		\$25,000
	Subtotal Demolition/Disposal				\$585,700
III. SITE WORK					
	A. Repair Brick Walkways at Base of Lighthouse	1	LS		\$6,000
	B. Archaeology: Main Entrance Stairway & General Site Clearance	1	LS	NPS*	\$0
	C. Post-costruction Clean-up and Site Restoration	1	LS		\$5,000
	Subtotal Site Work				\$11,000
IV. MASONRY					
	A. Repair Top 20-feet of Masonry/ Replace 1000 Damaged Bricks		LS		\$41,000
	B. Repoint Interior Masonry Walls and Passages 100%	5,500	sf	\$22.00	\$121,000
	C. Repoint Exterior Masonry Walls 100%	8,500	sf	\$22.00	\$187,000
	D. Repair Concrete Topping at Watch Level Observation Deck	1	LS		\$600
	Subtotal Masonry				\$349,600
V. STEEL & IRON WORK					
	A. Install Replacement S.S. Tension Ring, Plate, Anchors	1	LS		\$6,000
	B. Repair Lantern's Wall and Roof Framing	1	LS		\$19,200
	C. Repair Lantern Gallery Deck and Railing	1	LS		\$4,000
	D. Replace Pipe Railing of Watch Level Observation Deck	16	sections	\$1,600.00	\$25,600
	E. Instll Three (3) Existing Spiral Staircase Treads	3	treads	\$350.00	\$1,050
	F. Reinforce Spiral Stairs	165	treads	\$135.00	\$22,275
	G. Repair Stairs to Watch Level & Cast/Install 2 Treads	1	LS		\$7,500
	H. Repair Stairs to Lantern level & Cast/ Install 2 Treads	1	LS		\$4,000
	I. Repair Cast Iron Handrail at Spiral Stairs	1	LS		\$1,000
	J. Install New Second Handrail for Spiral Stairs	1	LS		\$26,070
	K. Install Supplemental Handrail at Stairs to Watch Level	1	LS		\$2,040
	Subtotal Steel & Iron Work				\$119,095
VI. WOODWORK					
	A. Rough Carpentry				
	1. Temporary Shoring of Top 20 Feet of Masonry	1	LS		\$4,050
	2. Framing for Temporary Roof	1	LS		\$2,050
	3. Reconstruct Two Exterior Doorway Units	2	doorway	\$2,300.00	\$4,600

	B. Finish Carpentry				
	1. Reconstruct Part of Board Wall & Second Wall at Service Level	1	LS		\$2,200
	2. Reconstruct Shelves for Cabinet at Observation Level	1	LS		\$500
	3. Reconstruct Main Entrance Stairway	1	LS		\$4,400
	C. Millwork/Doors & Windows				
	1. Repair/Conserve Window Sash	10	pair of sash	\$200.00	\$2,000
	2. Install Reproduction Board-and-Batten Entrance Doors	2	door leaf	\$2,000.00	\$4,000
	3. Install Reproduction Four-Panel Door at Service Level	2	door leaf	\$1,350.00	\$2,700
	4. Install Reproduction Sash Door at Second Floor	1	door leaf		\$1,750
	Subtotal Woodwork				\$28,250
VII. ROOFING					
	A. Repair Sheet Metal Lantern Roofing and Ventilator	1	LS		\$14,800
	B. Repair Lantern Built-in Gutters and Downspouts	1	LS		\$4,300
	C. Install Temporary Roofing	1	LS		\$1,000
	Subtotal Roofing				\$19,100
VIII. WINDOWS & DOORS					
	A. Repair Windows	See VI			
	B. Repair Doors	See VI			
	Subtotal Roofing - Windows & Doors				\$0
IX. GLASS					
	A. Reglaze Lantern	15	vertical sects	\$300.00	\$4,500
	B. Reglaze Lantern Door	1	door leaf/sect	\$400.00	\$400
	Subtotal Glass				\$4,900
X. DRYWALL/PLASTER					
	Subtotal Drywall/Plaster				
XI. FINISHES					
	A. Apply Limewash to Interior Masonry	5,500	sf	\$7.00	\$38,500
	B. Apply Finish Coating to Exterior Masonry	8,500	sf	\$7.00	\$59,500
	C. Paint Spiral Staircase (five levels of treads and two handrails)	5	stair level	\$4,000.00	\$20,000
	D. Paint Two Ladder Stairs	2	stair section	\$450.00	\$900
	E. Paint Five Full Landings	5	landing	\$450.00	\$2,250
	F. Paint Two Half-Landings	2	half-landing	\$225.00	\$450
	G. Paint Observation Deck and Railings	1	LS		\$800
	H. Paint Interior/ Exterior of Lantern, Gallery, Roof & Ventilator	1	LS		\$2,800
	I. Paint Three Exterior Door Units (first, second and eighth floors)	3	door unit	\$300.00	\$900
	J. Paint Service Area Board Walls (2) and Door Units (2)	1	LS		\$500
	K. Paint Observation Level Cabinets	1	LS		\$400
	L. Paint Window Units	10	window unit	\$400.00	\$4,000
	Subtotal Finishes				\$125,200
XII. MISCELLANEOUS SPECIALTIES					
	A. Retrofit and Make Operable Observation Level Wall Vents	4	unit	\$400.00	\$1,600
	Subtotal Miscellaneous Specialties				\$1,600

XIII. PLUMBING					
	Subtotal Plumbing				
XIV. MECHANICAL					
	Subtotal Mechanical				
XV. FIRE & INTRUSION					
	A. Install new Security Intrusion Alarm System	1	LS		\$5,000
	B. Install Heat/Smoke Detection System	1	LS		\$5,000
	C. Install Lightning Protection System	1	LS		\$20,000
	Subtotal Fire & Intrusion				\$30,000
XVI. ELECTRICAL					
	A. Install New Service	1	LS		\$12,000
	B. New Main Distribution Panel	1	LS		\$2,000
	C. Install New Interior Light Fixtures	20	each	\$200.00	\$4,000
	D. Install New Exterior Light Fixtures	4	each	\$500.00	\$2,000
	Subtotal Electrical				\$20,000
	Subtotal Direct Construction Costs				\$2,110,595
	Design Contingency (30 Percent)				\$633,179
	Total Direct Construction Costs				\$2,743,774
	Overhead (15 Percent)				\$411,566
	Profit (10 Percent)				\$274,377
	Estimated NET Construction Cost				\$3,429,717
	Inflation Escalation (12 Months at 4%)				\$137,189
	Total Estimated NET Cost of Construction				\$3,566,906