

FEDERAL LAW ENFORCEMENT TRAINING CENTER

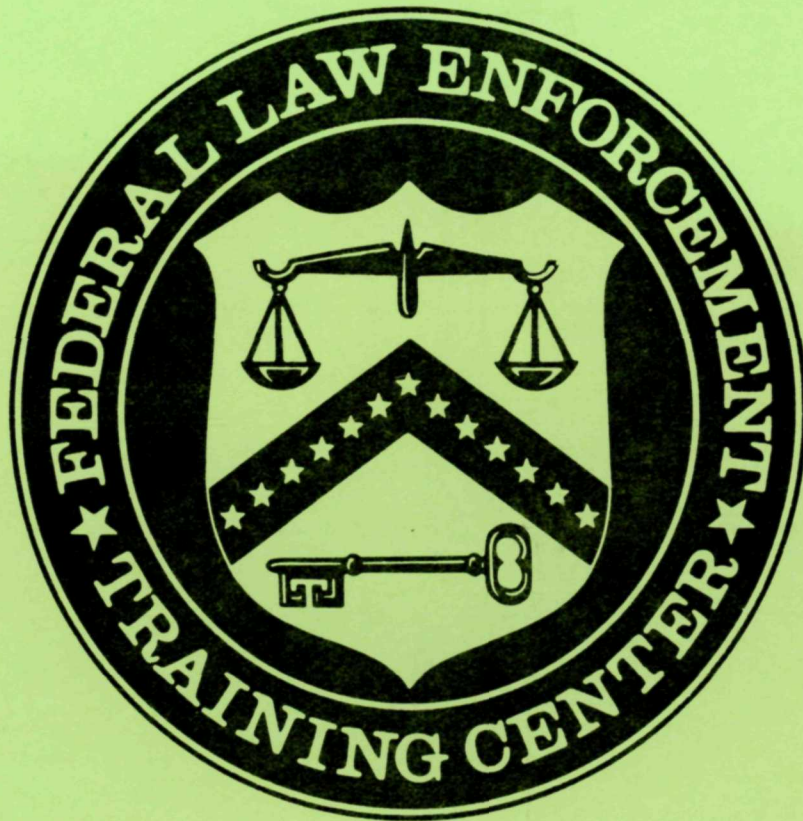

POLICE TRAINING DIVISION

POLICE PHOTOGRAPHY

TEXT

204.1

(8/71)

CAVEAT

This material was prepared by the Federal Law Enforcement Training Center for use in its training programs. Consequently, all reasonable efforts were made to make the policies and procedures set forth herein be in conformance with Federal law and regulations at the time of printing.

Anyone using this material for any other purpose should consider the possibility that Federal legislation and/or court interpretations after this material was sent for printing have made parts of the material obsolete and take appropriate action to satisfy themselves that the material is current.

PART I
BASIC PHOTOGRAPHY

PHOTOGRAPHY TEXT

PREFACE

The camera is a valuable tool for the criminal investigator. It enables him to record the visible, and in some cases even the invisible evidence of the crimes he is charged with investigating. In fact, no other process can record and retain criminal evidence as accurately and efficiently as photography.

An investigator does not have to be a professional photographer in order to take pictures that will be useful to him in the conduct of his investigations, or as evidence in court, but he should be able to use the camera with some degree of competence to consider himself a journeyman investigator.

This text is for the investigator who has had little or no experience with cameras. It is not a step-by-step manual of instruction, but an overview of the application of photography to the criminal investigative function. It is intended as a guide to assist the new investigator as he develops competence through actual use of cameras in the field.

Part I, Basic Photography, covers information more or less common to all applications of photography. Part II, Investigative Photography, covers material of more particular interest to a criminal investigator.

TABLE OF CONTENTS

PART I

CHAPTER 1: THE CAMERA

- 11. THE FOUR COMPONENTS OF A CAMERA
- 12. LENSES
 - 12.1 The Pinhole Lens
 - 12.2 The Simple Lens
 - 12.3 Compound Lenses
 - 12.4 Focal Length
- 13. SHUTTERS
 - 13.1 Diaphragm Shutter
 - 13.2 Focal Plane Shutter
- 14. TYPES OF CAMERAS
 - 14.1 Box Cameras
 - 14.2 Adjustable Cameras
 - 14.3 Automatic-Setting Cameras
 - 14.4 The 35mm Camera
 - (1) Rangefinder type
 - (2) Single-lens reflex type
 - 14.5 The Twin-Lens Reflex
 - 14.6 Subminiature Cameras
 - 14.7 Press and View-Type Cameras
 - 14.8 Polaroid Cameras
 - 14.9 Motion Picture Cameras

CHAPTER 2: CONTROLLING THE AMOUNT OF LIGHT THAT ENTERS THE CAMERA

- 21. LENS SPEED
 - 21.1 The f-number
 - 21.2 The Variable Aperture
- 22. SHUTTER SPEED
 - 22.1 Calibration
 - 22.2 Lens Speed/Shutter Speed Relationship
 - 22.3 Choice of Shutter Speed
 - 22.4 Camera Shake

CHAPTER 3: FOCUS AND DEPTH OF FIELD

- 31. FOCUS
- 32. DEPTH OF FIELD
 - 32.1 The One-Third Rule
 - 32.2 The Aperture and Distance Rules

CHAPTER 4: THE FILM

- 41. FILM SPEED: ASA RATING
 - 42. ORTHO AND PAN FILMS
 - 43. GRAININERS
 - 44. FILM LATITUDE
-

-
- 45. BLACK-AND-WHITE FILM
 - 45.1 General Considerations
 - 45.2 Type 2484
 - 46. COLOR NEGATIVE FILM
 - 47. COLOR REVERSAL FILM
 - 48. POLAROID FILM (See Paragraph 14.8)

CHAPTER 5: HOW TO TAKE GOOD PICTURES

- 51. CONSIDER FOCUS, EXPOSURE, AND COMPOSITION
 - 52. TRY FOR MAXIMUM SHARPNESS
 - 53. WORK FOR OPTIMUM EXPOSURE
 - 53.1 Consider Film Latitude
 - 53.2 Use the Data Sheet and Bracket the Exposures
 - 54. USE OF FLASH
 - 55. COMPOSE THE PICTURE
 - 55.1 The General Rules
 - 55.2 A Fair and Accurate Representation
 - 56. KEEP A LOG
-

BASIC PHOTOGRAPHY

CHAPTER 1

THE CAMERA

11. THE FOUR COMPONENTS OF A CAMERA

All cameras are basically similar and include four essential components:

- (1) Lens
- (2) Shutter
- (3) Film support (film plane)
- (4) Light-tight enclosure to hold the other elements together

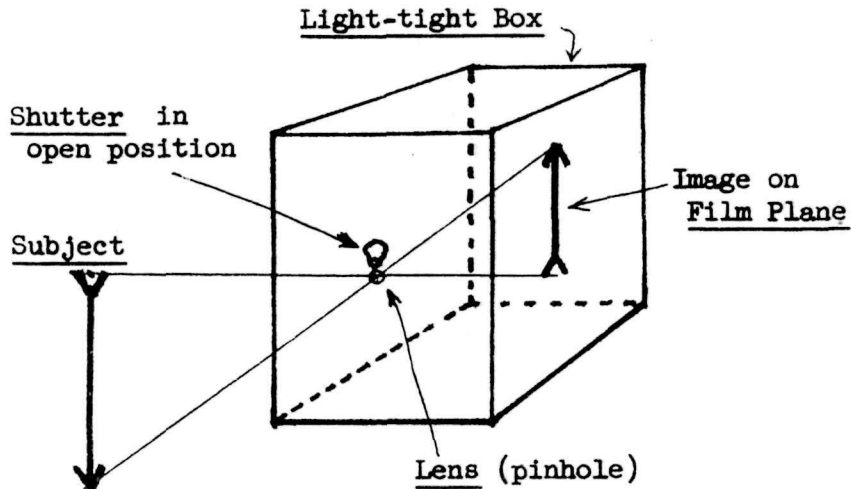

12. LENSES

12.1 The pinhole lens. The most important component of a camera is the lens. The lens is the window through which light enters the camera. The simplest "lens" is merely a pinhole. However, a photograph taken with a pinhole camera is not very sharp because a point in the scene is reproduced in the film plane as a spot which can never be smaller than the pinhole itself. Also, because of the very small size of the hole, its light-transmitting power is very low.

12.2 The simple lens. A simple glass lens which concentrates the rays of a beam of light at one point in the film plane solves the pinhole problem. However, rays entering a simple lens at wide angles to the optical axis are not all concentrated at one point. Deviations from

BASIC PHOTOGRAPHY

the ideal image are called lens errors or aberrations. The errors inherent in a simple lens are:

- (1) Spherical aberration (marginal rays focus at a point closer to the lens)

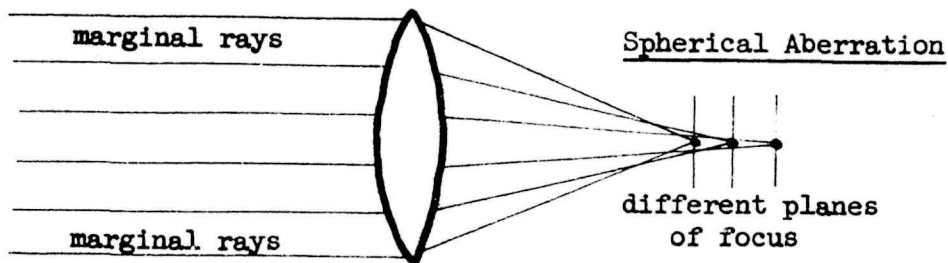

- (2) Astigmatism and curvature (two mutually perpendicular rays passing obliquely through a lens are concentrated on two surfaces of different curvature)

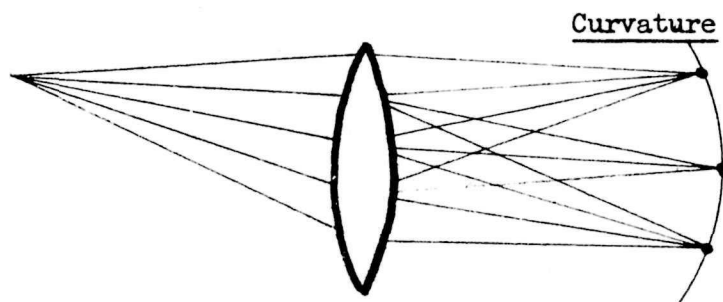

- (3) Coma (comet-like elongation of points outside the center of the image)

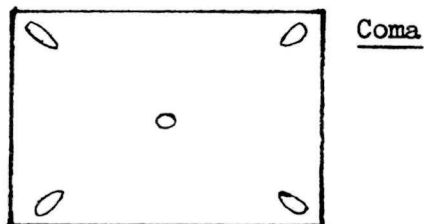

- (4) Distortion (straight lines appear curved)

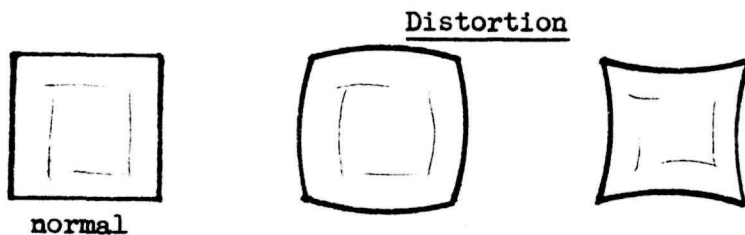

5. Chromatic aberration (light rays of different colors do not focus at the same point)

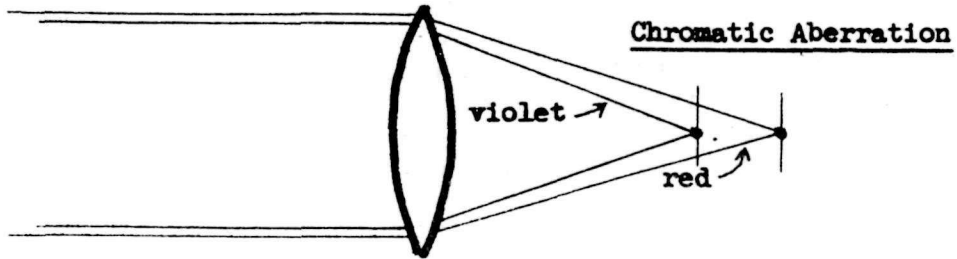

12.3 Compound lenses. Such errors can be corrected. Hundreds of varieties of glass differing in refractive index (light bending ability) and dispersion (the separation of light into colors) are available to the lens designer. By varying the number of elements, the type of glass, the curvature, thickness, and air gaps between elements, it is possible for the lens designer to reduce the errors inherent in the simple lens to acceptable values. If a convergent lens is combined with a suitable divergent lens which has been shaped to have half the light bending power of the convergent lens but is made of glass which has twice the color dispersion, the light bending power of the combination is cut in half but the chromatic aberration is entirely eliminated. Such a lens is called an achromatic lens (light rays of all colors from a given point are focused at the same point in the film plane). A lens which has been corrected for astigmatism is called an anastigmatic lens (all light rays, from whatever angle, focus in the same plane). Other lens errors can be corrected similarly by the appropriate combination of several elements made of different optical properties.

Three Element Lens: Kodak Ektanar Lens, 44mm f/2.8, used on the Kodak Signet 30 and Signet 50 cameras.

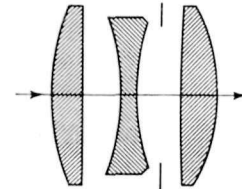

Six Element Lens: Kodak Retina Longar Lens, 80mm f/4.0, used in conjunction with a three-element rear lens for longer focal length.

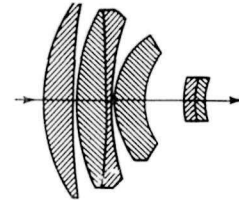

Six Element Lens: Kodak Retina Curtar Lens, 35mm f/5.6 and f/4.0, used with a three-element rear lens for wide-angle pictures.

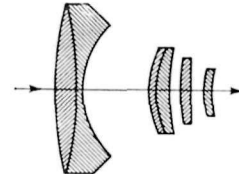

BASIC PHOTOGRAPHY

12.4 Focal length. The focal length of a lens is the distance from the lens to the point where the light rays are sharply focused. The focal length of a lens is a property of the lens and never changes. All lenses of the same focal length produce images of the same size. Long focal length lenses or telephoto lenses, produce larger images, and short focal length lenses, or wide-angle lens, produce smaller images. But wide angle lenses have a much wider field than telephoto lenses and can take in much more of the scene to be photographed.

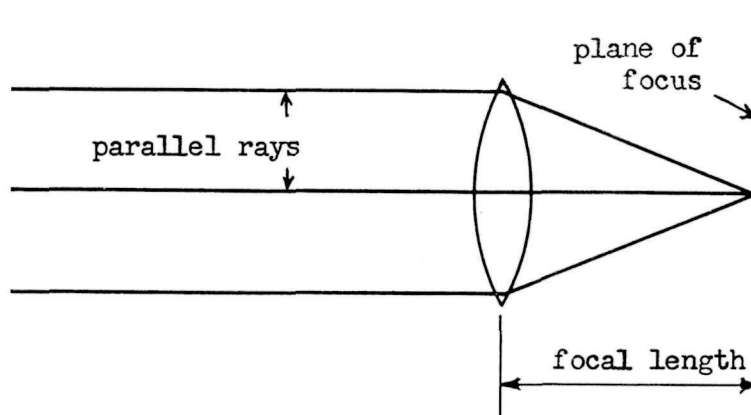

The "normal" focal length is about 50 mm. "Normal" in this context means the focal length which produces snapshot size images with the perspective natural to the human eye. Fully corrected lenses in focal lengths from about 8 mm to 2000 mm are available on the market today. Zoom lenses that shift focal length without shifting focus are also available.

13. SHUTTERS

13.1 Diaphragm shutters. The function of a camera shutter is to let in the light for a controlled, usually very brief, length of time. Several kinds of mechanisms can do this, but only two are used for general-purpose cameras. These are the diaphragm shutter and the focal plane shutter. Diaphragm shutters are usually mounted "between-the-lens", that is, between the elements of the lens, but they are sometimes located just behind the lens. The diaphragm shutter is made up of four or five thin metal leaves or blades which rotate outward in the shutter plane as the shutter opens, and close back down again as the shutter

closes. It takes about $1/500$ second for this kind of shutter to open and close, so it cannot be used for speeds faster than that. The diaphragm shutter is ideal for use with flash because regardless of the shutter speed the flash (if it is synchronized with the shutter) will strike all areas of the film plane simultaneously.

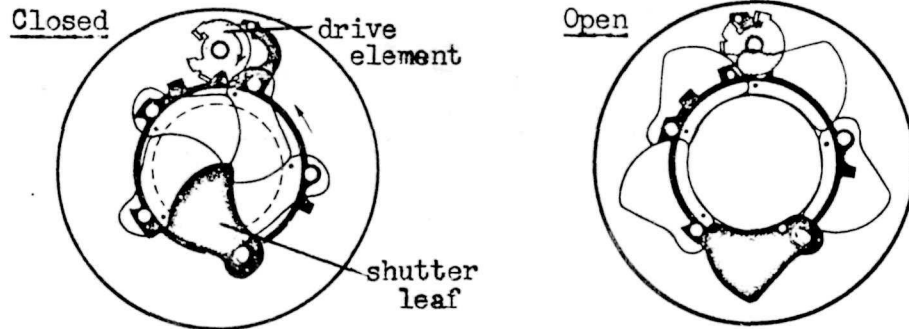

13.2 Focal plane shutters. The focal plane shutter is mounted at the film plane and moves across the plane just in front of the film. This kind of shutter is usually made up of two opaque roller blinds which move in the same guide tracks. When the shutter is released, the first blind is drawn aside and rolled onto a spool by means of a spring. After the pre-set interval, the second blind unrolls across the film plane and covers the film again. The two blinds working together thus form a slit which travels across the film plane. If the pre-set exposure time is very short, the second blind will follow the first one very quickly so that only a very narrow slit is formed. This type of shutter can attain very fast effective shutter speeds but cannot be used with normal flash or electronic flash because the flash will only strike that portion of the film which is exposed by the slit at the instant the flash goes off. However, special slower burning bulbs, called FP bulbs, are available which burn at full intensity for the duration of the exposure. The FP stands for focal plane.

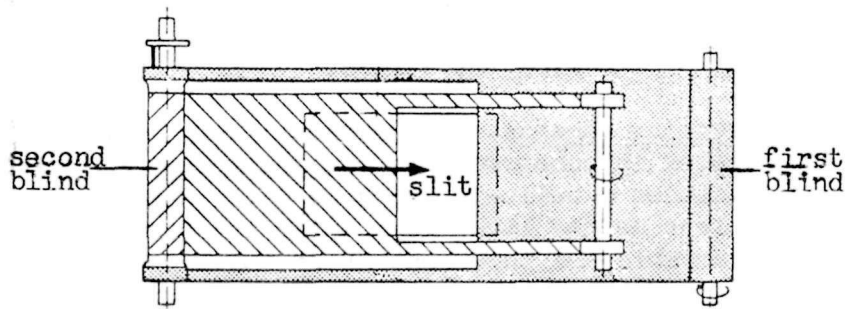

14. TYPES OF CAMERAS

14.1 Box cameras. The simple box camera is easy to operate because the aperture, shutter speed, and focal distance are preset by the manufacturer to produce satisfactory pictures under good lighting conditions. These cameras cannot focus on objects closer than about

BASIC PHOTOGRAPHY

6 or 8 feet and cannot take pictures in dimly lit places, or take action shots. But, within these limits, simple box cameras can take pictures that are satisfactory in every respect.

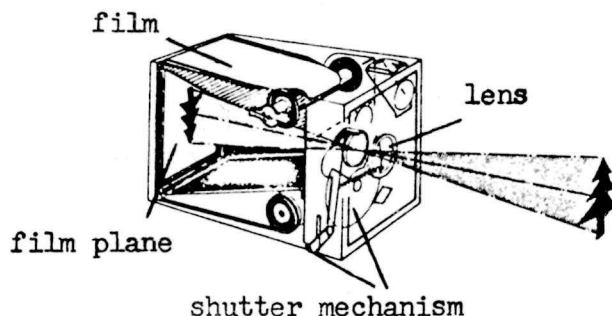

14.2 Adjustable cameras. Adjustable cameras, as distinguished from box cameras, have features that make them more versatile. The most important of these features are:

1. Adjustable diaphragm for controlling the lens aperture size
2. Shutter speed control
3. Focus control

The variable aperture control and shutter speed control combine in their operation to enable the photographer to let in the amount of light necessary to take good pictures under changing light conditions, and the focus control enables the photographer to get the subject in sharp focus whether it is near or far from the camera.

14.3 Automatic-setting cameras. The modern, fully automatic cameras, although very complex in construction, are still easy to operate. This type of camera includes a built-in exposure meter that measures light intensity at the lens as the light rays enter the camera. The meter is attached to the variable aperture control of the lens to automatically adjust the opening according to the light intensity. This action is synchronized with the shutter speed. Once the camera is set for the speed of film being used, proper exposure adjustments for almost all conditions are automatically made. Some of the new models also include an automatic method for setting the correct focus. With this type of camera, the photographer is relieved of making adjustments for technical details and can concentrate on subject matter and composition. These

BASIC PHOTOGRAPHY

cameras are available for 35 mm and cartridge-loaded 126 film size as well as for polaroid film.



14.4 The 35mm camera. The 35mm camera is probably the most versatile and popular of all cameras. Most models have a wide variety of quick-change lenses and other accessories available which make it possible for the photographer to take pictures under almost any circumstances. Such cameras have either window-type viewfinders (rangefinder) or viewers that sight through the camera lens (single-lens reflex).

- (1) The rangefinder type. The rangefinder (RF) type may have a superimposing rangefinder or a split-field rangefinder. The superimposing rangefinder will show two images until the focus is correct. When the focus is correct, the two images will be perfectly superimposed and appear as one image. The split-field rangefinder will show two half images until the focus is correct. When the focus is correct the two halves will be matched and appear as a single complete image.

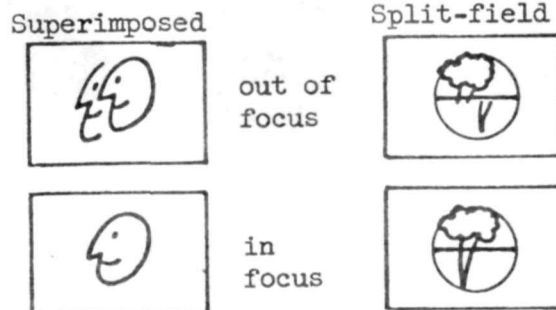

- (2) The single-lens reflex type. The single-lens reflex (SLR) type permits viewing and focusing through the lens of the camera rather than through a separate viewfinder. This is accomplished with a mirror and a prism that work together to correct the reversed and upside down image transmitted

by the lens so as to reflect it through the viewfinder in an unreversed and rightside up position.

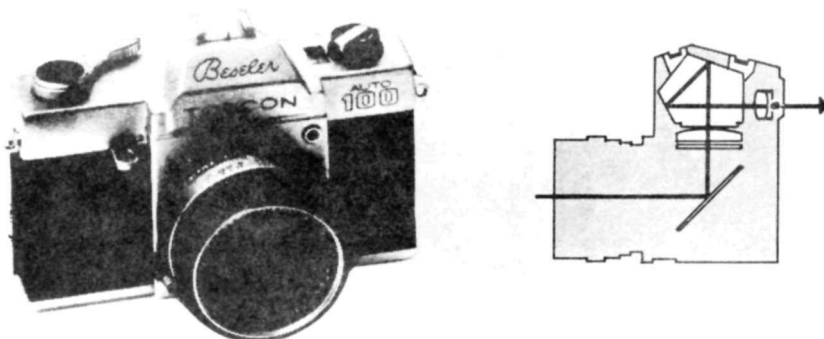

14.5 The twin-lens reflex camera (TLR). This camera has two lenses, the lower for taking pictures and the top for viewing. The viewing screen is made of ground glass and gives an accurate but upside down view of the subject in the same size that will appear on the film negative. The most popular negative size is $2\frac{1}{4}$ " x $2\frac{1}{4}$ " (120 film size). Such negatives are convenient to handle and can be used to make positive slides or enlarged prints.

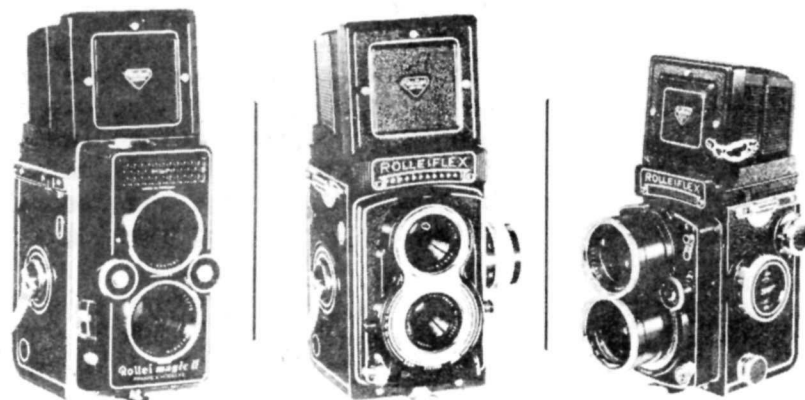

14.6 Subminiature cameras. When 35mm cameras were first developed (1924) they were referred to as "miniature". Later, therefore, when still smaller cameras were developed (1934) the new ones were called "subminiature". These cameras are convenient to carry and, because of the short focal length, are useful for close-up work such as copying documents or photographing small objects. But, because of the small negative size (8mm or 16mm), and the focusing and support problems inherent in the use of such small cameras, the quality of finished enlargements often falls below the level of professional acceptance.

Contrary to popular notion, these cameras are seldom used in surreptitious photography. In such situations, better results are usually obtained with larger format cameras used from blinds, or with long focal length lenses.

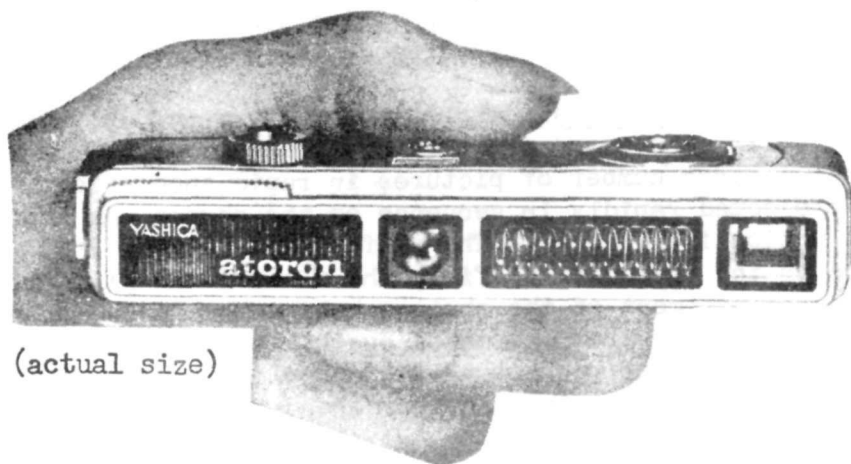

(actual size)

14.7 Press and view-type cameras. These cameras are sometimes called "sheet-film" cameras because they accept cut sheets of film as well as roll film, thus permitting single pictures to be taken and immediately processed. The larger negative size (4" X 5" or 8" X 10") permits extreme enlargements without loss of quality. Such cameras are ideal for copy work and close-up photography because viewing and focusing are done on a ground glass surface directly in line with the lens permitting maximum accuracy. The view-type cameras also have controls for "tilting" and "swinging" the lens in relation to the film plane. This enables the photographer to modify the perspective and shift the plane of the depth-of-field to solve difficult compositional problems.

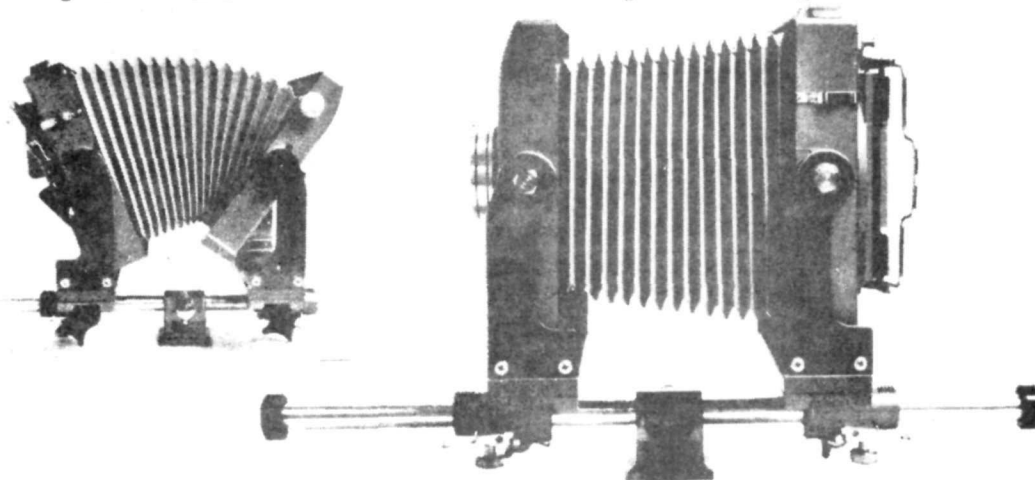

14.8 Polaroid cameras. The distinguishing feature of polaroid cameras is that the film is developed and prints made immediately in the camera after a picture is taken, thus eliminating waiting time and the need for a darkroom. Prints in both black-and-white and color, and slides in black-and-white can be produced quickly. Polaroid film consists of

negative film and positive stock with a sealed pod containing developing chemicals affixed at one end. After a picture is taken, a pull advances the film through rollers which squeeze the developer from the pod and spread it between the negative and positive stock. Development takes place in a matter of seconds depending on the type of polaroid film used.

14.9 Motion picture cameras. There is no difference in principle between an ordinary still camera and a motion picture camera, except that the movie camera takes a large number of pictures in rapid succession. so that when these are projected rapidly in sequence on the screen, an impression of continuous motion is produced. The differences between still and movie cameras are in the threading of film, the flow of the film through the camera, and the movement of the shutter behind the lens. Slow-motion and time-lapse effects are determined by the ratio of the speed of shooting the film to the speed of projecting it. Slow motion is produced by running the film through the camera at a higher speed than through the projector.

Cinama Beaulieu Auto 16

Has fully automatic exposure control with interchangeability of lenses with zoom ratios from 4:1 to 10:1.

All functions operate off a single-system power supply. Both 100-foot and 200-foot magazines are available.

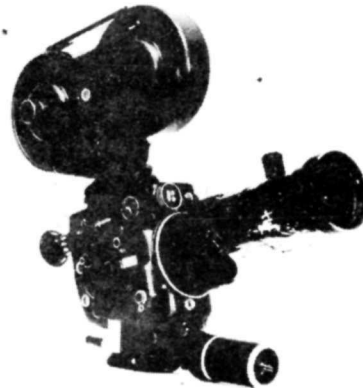

BASIC PHOTOGRAPHY

CHAPTER 2

CONTROLLING THE AMOUNT OF
LIGHT THAT ENTERS THE CAMERA

21. LENS SPEED

21.1 The f-number. When the shutter is open on a camera, the film receives a quantity of light that depends on the size, or diameter, of the lens. The larger the lens, the more light hits the film. A lens of large diameter which lets in a lot of light is called a "fast" lens and conversely, a lens of small diameter which allows only a small amount of light to strike the film, is called a "slow" lens. For this reason the transmitting power (speed) of a lens is designated by the ratio of the diameter of the lens to its focal length (the distance from the lens to the film). For example, if a camera lens has a diameter of 25mm and a focal length of 50mm, it has a ratio of 1 to 2 ($25/50$ equals $1/2$). This ratio is a "factor" and is referred to as an "f-number". The ratio, or factor, is always reduced so that the numerator of the ratio (the top number) is one ($25/50$ equals $1/2$). Therefore, only the denominator (the bottom number) will vary as the diameter changes, and a lens with a diameter of 25mm and a focal length of 50mm would be referred to as an "f-two" lens (written $f/2$). A lens with a diameter of 10mm and a focal length of 40mm would be referred to as an "f-four" lens (written $f/4$).

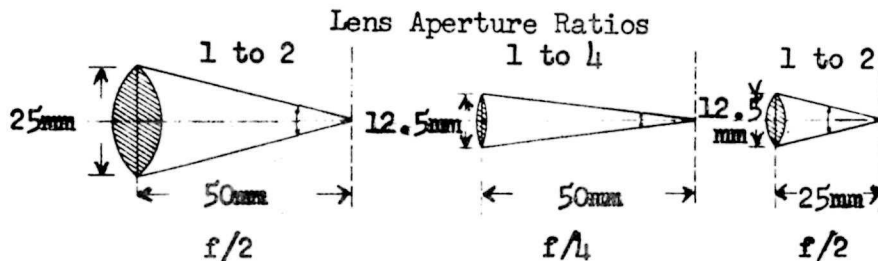

21.2 The variable aperture. It is not necessary to change lenses to obtain a "slower" lens speed. In order to cut down on the amount of light going through the lens, the hole can be made smaller by means of a variable diaphragm behind the lens. When the effective diameter of the lens is changed in this manner by the diaphragm, the new effective lens speed (f-number) is shown opposite the index on the variable aperture control ring on the camera. These f-stops are predetermined so that each higher f-number (smaller hole) corresponds to a reduction of about one-half in the light transmitting power of the lens. Hence, an $f/2$ lens is twice as "fast" as an $f/2.8$ lens, and four times as "fast" as an $f/4$ lens. In other words, twice as much light gets in the camera at $f/2$

than gets in at $f/2.8$, and four times as much light at $f/2$ than at $f/4$.

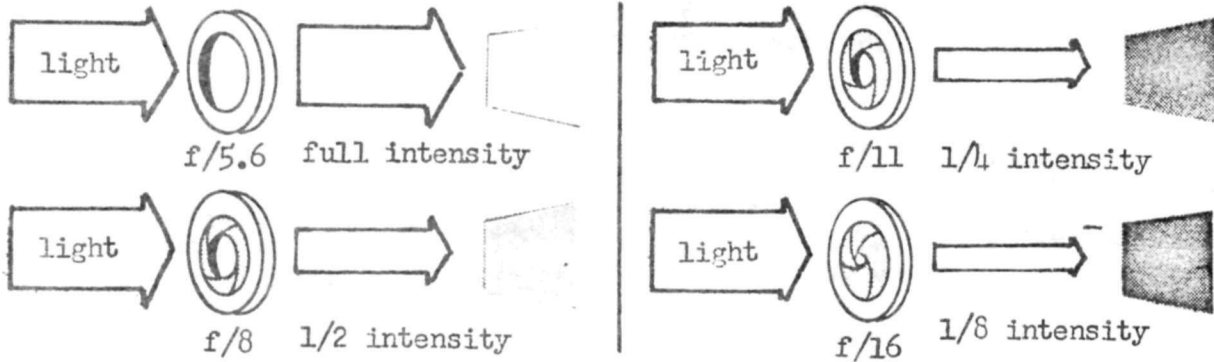

22. SHUTTER SPEED

22.1 Calibration. The amount of light that gets into the camera can be controlled by the shutter which can be set to stay open for variable lengths of time. The time that a shutter stays open is referred to as shutter "speed". Shutter speeds are measured in fractions of a second: $1/2$, $1/4$, $1/8$, On the camera control, they are printed as whole numbers rather than fractions: 2, 4, 8, A shutter speed of $1/50$ second is slower than one of $1/100$ second because it stays open for twice as long a time.



Shutter speed control ring

f/stop control ring

distance scale

(Hasselblad camera)

22.2 Lens speed/shutter speed relationship. Since a one-stop change in either the shutter speed control or the variable aperture control (f-number) results in doubling, or cutting in half the amount of light that gets into the camera (depending on the direction of change), there is a one-to-one relationship between the aperture control and shutter speed. Thus, for a particular picture taking situation, there is a

variety of shutter speed and f-number combinations that will allow the same total amount of light into the camera. For example:

All of these settings let in the same amount of light:

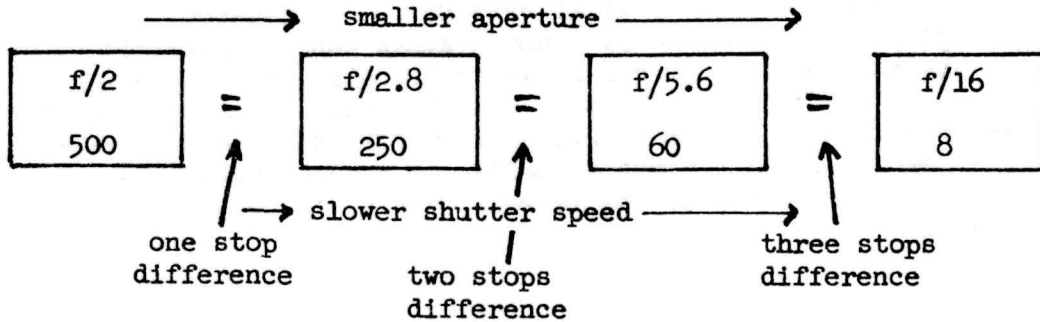

22.3 Choice of shutter speed. Shutter speed becomes important when moving subjects are to be photographed. The choice of shutter speed depends on the speed and direction of movement of the subject in relation to the camera. The shutter speeds necessary to "stop" various subjects are as follows:

	Direction of Movement		
	↓↑	↗↘	→←
	Shutter Speeds		
	25	50	100
Street scenes, people talking, quiet pedestrians, slow-moving cars, parades			
Hurrying people, playing children, swimmers, cyclists, waves, waterfalls	50	100	250
Racers, quick-moving cars, jumping, skating, dancing, horse-racing	100	250	500
Tennis, baseball, basketball, football, soccer, water skiing, motorboating, birds in flight	250	500	1000
All sports and racing when they are at their peak activity	500	1000	

NOTE: These shutter speeds are for a shooting distance of about 30 feet. If you are shooting from 15 feet, double the speeds given. If you are shooting from 60 feet, cut the speeds in half.

22.4 Camera shake. The selection of shutter speed is also important because of camera "shake". Camera shake is the movement caused by the Photographer himself as he holds the camera to take the picture. Nobody can hold a camera absolutely still even for a split-second. Every hand-held shot is more or less unsteady. Camera shake can be minimized by using faster shutter speeds. It can be virtually eliminated by using a tripod, or other solid support rather than hand-holding. Camera shake probably causes more trouble for the beginner than any other factor. When the beginner has mastered the art of holding a camera steady (the pros use a tripod whenever possible) he is well on his way to professional competence.

CHAPTER 3

FOCUS AND DEPTH OF FIELD

31. FOCUS

The sharpness of human vision has its limitations, and some lack of sharpness in a picture can be tolerated without being objectionably noticeable as blurring or "fuzziness". Just how much lack of sharpness is acceptable will depend on how much the picture is to be enlarged and on how much importance the observer attaches to minute details in the picture. In a sharply focused image, each point of the subject or scene is reproduced as a point in the film plane image. If the image is out of focus, each point is reproduced as a tiny "circle of confusion", or fuzziness in the image. The normal eye, at 10 inches, accepts a circle of confusion of 1/100 inch as a point. Most lenses are capable of resolution to 1/500 inch. The commercial standard is about 1/500 inch.

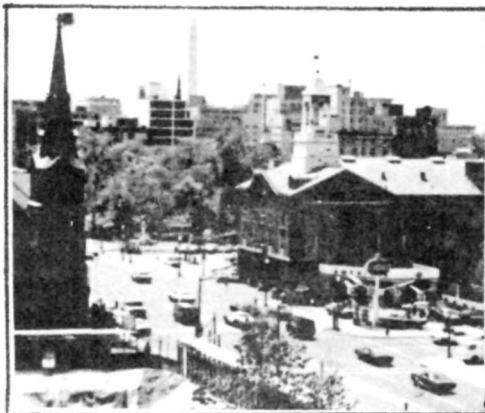

Lens focused at infinity



Lens focused at 3 feet

The picture on the right is badly out of focus. Notice how the points of light become circles of confusion.

32. DEPTH OF FIELD

32.1 The one-third rule. The depth of field in photography is the range or distance in front of the camera in the field of the lens which is in sharp focus. Another way of saying this is that the depth of field is the distance from the closest sharply focused point to the farthest sharply focused point in the field of the camera. Of the total depth of field within a scene, about one-third is included ahead of the point of sharpest focus and about two-thirds beyond the point of sharpest focus. Therefore,

BASIC PHOTOGRAPHY

to get the maximum advantage of the depth of field, the lens must be focused on a point that is about one-third the way into a scene.

f/5.6

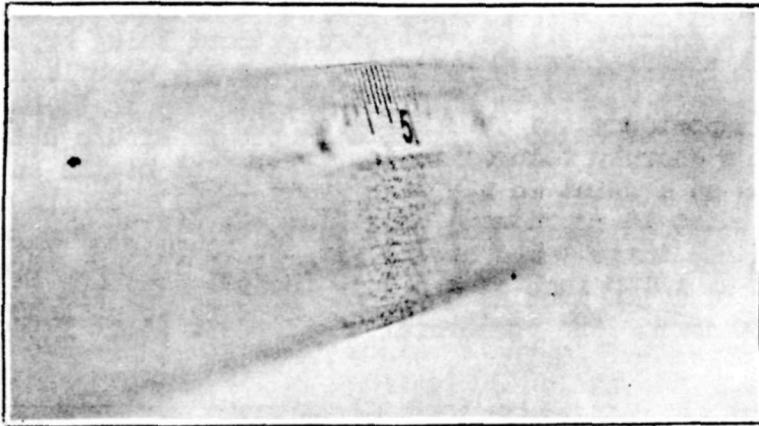

f/16

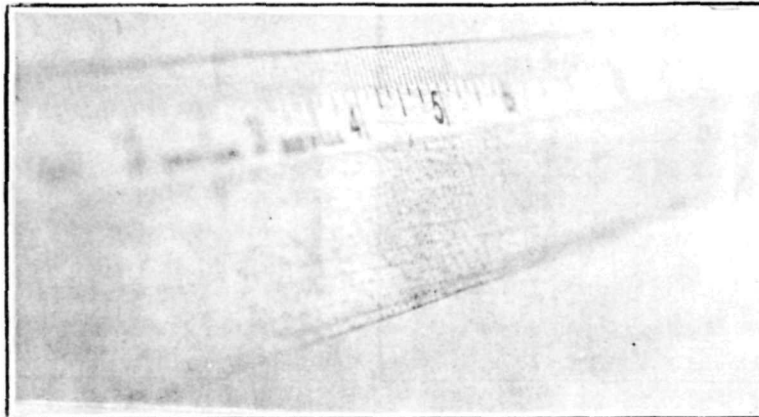

f/32

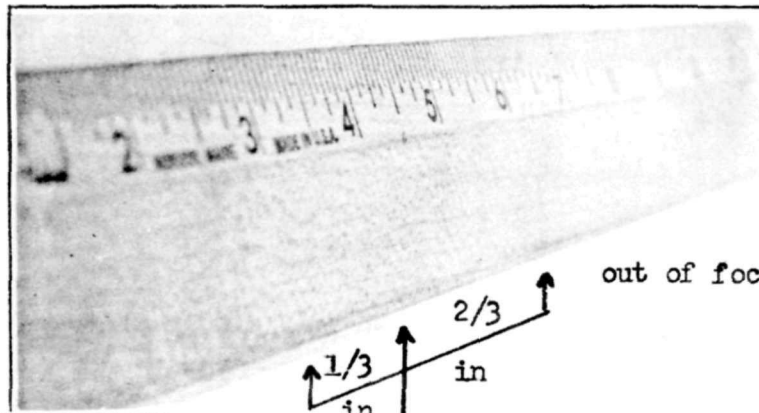

out of focus

SHARP

out of focus

32.2 The aperture and distance rules.

1. For a given aperture, depth of field increases as the distance from the lens increases.
2. For a given distance from the lens, depth of field increases as the aperture decreases.

Most 35mm cameras have a depth of field scale adjacent to the distance scale. Depth of field can be determined quickly from such a scale for any combination of aperture setting (f-number) and distance.

Below is a depth-of-field table for a 55mm lens (Honeywell Pentax Super-Takamur). Subtract the upper distance from the lower distance to obtain the depth-of-field for a given f/stop at a given distance.

Distance Scale f Setting	1'6"	2'	3'	5'	10'	15'	30'	∞
f/1.8	1' 5.9" 1' 6.1"	1'11.8" 2' 0.2"	2'11.5" 3' 0.6"	4'10.4" 5' 1.7"	9' 5.6" 10' 7.2"	13' 9.7" 16' 5"	25' 6.4" 36' 4.7"	168' 2.4" ∞
f/2	1' 5.9" 1' 6.1"	1'11.8" 2' 0.2"	2'11.4" 3' 0.6"	4'10.3" 5' 1.8"	9' 4.9" 10' 8"	13' 8.3" 16' 7.1"	25' 1.3" 37' 3.2"	151' 4.8" ∞
f/2.8	1' 5.9" 1' 6.1"	1'11.6" 2' 0.4"	2'11.2" 3' 0.8"	4' 9.6" 5' 2.6"	9' 2.3" 10'11.5"	13' 2.8" 17' 4"	23' 7" 41' 3.4"	108' 2.3" ∞
f/4	1' 5.8" 1' 6.2"	1'11.5" 2' 0.5"	2'10.8" 3' 1.2"	4' 8.6" 5' 3.8"	8'10.7" 11' 5.3"	12' 7.1" 18' 6.7"	21' 7.2" 49' 2.8"	75' 9.5" ∞
f/5.6	1' 5.6" 1' 6.4"	1'11.4" 2' 0.7"	2'10.4" 3' 1.8"	4' 7.4" 5' 5.4"	8' 6.1" 12' 1.7"	11'10.1" 20' 6.2"	19' 5.2" 66' 3.4"	54' 2.3" ∞
f/8	1' 5.5" 1' 6.5"	1'11" 2' 1"	2' 9.8" 3' 2.5"	4' 5.6" 5' 8.2"	8' 13' 4.4"	10'10.3" 24' 4.6"	16'10.7" 138' 2.8"	37'11.9" ∞
f/11	1' 5.4" 1' 6.7"	1'10.8" 2' 1.3"	2' 9" 3' 3.6"	4' 3.6" 5'11.8"	7' 5.4" 15' 3.7"	9'10.1" 31'10.8"	14' 6.2" ∞	27' 8.2" ∞
f/16	1' 5.2" 1' 7"	1'10.3" 2' 2"	2' 7.8" 3' 5.5"	4' 0.6" 6' 6.8"	6' 8.2" 20' 3"	8' 6.2" 66' 9.2"	11' 9.4" ∞	19' 1" ∞

CHAPTER 4

THE FILM

41. FILM SPEED: ASA RATING

Films vary greatly in their sensitivity to light. In the United States, this sensitivity is measured by a standard accepted officially in 1943 and known as the ASA rating (for American Standards Association). This rating is determined by testing new film at different shutter speeds at f/16 in bright sunlight. For example, if best results are obtained at a shutter speed of 1/60 second in bright sunlight at f/16 the film would be rated as ASA 60. If best results are obtained at a shutter speed of 1/500 second, the rating would be ASA 500. In Europe, the German standard is used. This is called the DIN rating (for Deutsche Industrie Normen). There are several other standards in use but these two, the ASA and the DIN are more commonly used than any of the others. The ASA and DIN ratings compare as follows:

ASA:	12	25	50	100	200	400	800
DIN:	13	16	19	22	25	28	31

42. ORTHO AND PAN FILMS

So far as tonal reproduction of colors is concerned, films today are of two main types -- orthochromatic and panchromatic. Ortho film is sensitive only to light waves in the blue end of the spectrum. Pan films are sensitive to all wave lengths in the visible range of the spectrum. Originally, films were sensitive only to wave lengths in the blue end of the spectrum. As film technology advanced, techniques were developed to make the film sensitive to the red end of the spectrum as well. The tendency today is to use panchromatic films for all purposes, although orthochromatic films are good for special purposes. Ortho film generally has more latitude and can be handled in the darkroom under a red light since it is not sensitive to red light. Ortho film also tends to have more contrast (greater sparkle and "snap") than pan film and is therefore good for low contrast (dull) lighting conditions. Today, Ortho films are used mainly in laboratory work.

43. GRAININESS

Generally, the faster the film the grainier it is. Very fast films can be made which are also very fine grained, but this is an expensive

process. For commercial reasons, manufacturers must sacrifice speed for fine grain. Modern films are composed mainly of microscopic crystals of silver halides. When exposed to light, something happens to these crystals which causes them to produce silver grains when placed in the chemical developer. The graininess apparent in the finished print is the result of the clumping of the silver particles which have come in contact with each other during processing and have developed as a single unit. This graininess will be most apparent in the medium grey tones of an enlarged print and may often be seen in skies and similar half-tones. The more the negative is enlarged, the more apparent will the graininess be, and this must be taken into account when big enlargements are wanted. Over-exposure tends to increase graininess. Therefore, exposure should be kept to the necessary minimum if the least possible graininess is desired.

graininess
not
apparent →



←
graininess
appears in
the enlarge-
ment



44. FILM LATITUDE

Some films can be over or under exposed by as much as 2 or 3 stops and still give acceptable results when developed and printed. Other films change contrast unacceptably if over or under exposed by as much as 1/2 stop. The film which can be over or under exposed by 2 or 3 stops is said to have wide latitude. The technical term for describing the quality which is lost by over or under exposure is "gamma." The gamma value of a negative is the ratio of negative contrast to subject contrast where contrast is defined as the relationship between the amount of light transmitted by the darkest parts of the negative and that transmitted by the lightest, or thinnest, parts. In plain English, this means that if the negative does not lose contrast because of over or under exposure, it has wide

latitude. Conversely, if the contrast of the negative, when compared to the contrast of the original subject, changes because of slight over or under exposure, it has narrow latitude.



good darks and lights



contrast lost due to underexposure

45. BLACK-AND-WHITE FILM

45.1 General considerations. Black-and-white films are inexpensive, easy to use, and simple to process and print. Their primary use is for making enlargements, but they can also be used to make slides and motion pictures. In order to use black-and-white films for slides, processing must be "reversed" so that the "negative" becomes "positive." Black-and-white films come in a wide range of speeds not possible with color films.

45.2 Type 2484. Of particular interest to law enforcement officers is a film introduced on the commercial market by Kodak in 1965, called 2475 Recording Film. It was at first available only on special order in 125-foot bulk rolls, but in 1967 it was made available over the counter in 36-exposure rolls. This film had a base rating of ASA 1000 but could be used at ASA 1600 in low contrast situations. With special "pushing" during development, it could be used at even higher ratings. In 1968, Kodak came out with an improved version called Type 2484. Type 2484 is an extremely high-speed fully panchromatic film useful for dimly lit subjects or when very fast shutter speeds are required. Depending on the contrast of the original scene and the development selected, this film can be used at speeds as high as ASA 3200.

46. COLOR NEGATIVE FILM

Color negative film is especially versatile in that it can be used to make both color and black-and-white prints. It can also be used to make color slides. In a color negative the colors of the subject are complementary to their normal appearance (yellow in place of blue, magenta for green, and cyan or blue-green for red). Kodacolor and Ektacolor are the principal color negative films available. They are more expensive than black-and-white films.

47. COLOR REVERSAL FILM

After exposure and processing, color reversal films become positives -- slides and motion pictures. In processing, the image is "reversed" to make a positive picture. Kodachrome and Ektachrome are the principal color reversal films available.

48. POLAROID FILM

Polaroid film is covered above in Paragraph 14.8.

CHAPTER 5

HOW TO TAKE GOOD PICTURES

51. CONSIDER FOCUS, EXPOSURE, AND COMPOSITION

All photographs can be evaluated in terms of three qualities. These qualities are:

- (1) Focus
- (2) Exposure
- (3) Composition

The photographer must consider all three of these factors and come up with a solution in terms of the purpose of the photograph. The way the photographer solves the problem will depend on what he intends to do with the picture after it is taken. The solution a studio photographer comes up with to make a picture of a subject for advertizing purposes will not be the same as the solution an investigator comes up with to make a picture of the same subject for use as evidence in court. The studio photographer will attempt to show the subject in the best possible light and may not be too concerned if the end product does not reflect the "warts and moles." The investigator, on the other hand, must come up with a fair and accurate representation of the reality or his photograph cannot be used as evidence in court.

52. TRY FOR MAXIMUM SHARPNESS

Although soft focus might be acceptable, or even desirable, in a studio portrait or a slick advertisement, sharp focus is mandatory in any photograph which purports to be a fair and accurate representation of the subject matter. In addition, the subject matter of investigative photography often involves more than one important item in the scene and all important items must be in sharp focus. This means that the investigative photographer must usually strive not only for the sharpest of possible focus but also for the maximum depth of field.

53. WORK FOR OPTIMUM EXPOSURE

53.1 Consider film latitude. Although over and under exposure may be acceptable for the sake of art, and although exposure errors can often be compensated for during the development and printing stages of picture making, there is usually a loss of "gamma" in such pictures which makes them unacceptable for use as evidence in court. Gamma, you will recall, is the technical term for the relationship between the contrast in the picture as compared to the contrast in the original scene. When this relationship is altered, the picture cannot be said to

be a fair and accurate representation of the subject. Some films, such as Kodacolor (color negative film) have the ability to suffer 2 or 3 stops of over or under exposure without losing gamma and when these films are processed, the exposure error can be compensated for without loss of the contrast relationship. Other films, such as Kodachrome (color reversal film) begin to lose gamma if they are over or under exposed by as much as 1/2 stop, and this loss cannot be fully corrected. The investigative photographer must therefore strive for the best possible exposure.

Over-
exposed

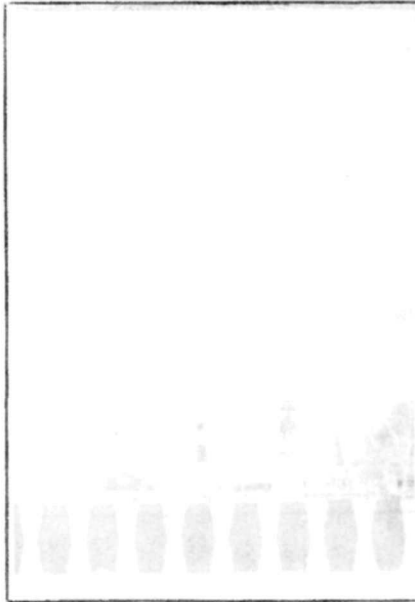

Normal



Under-
exposed

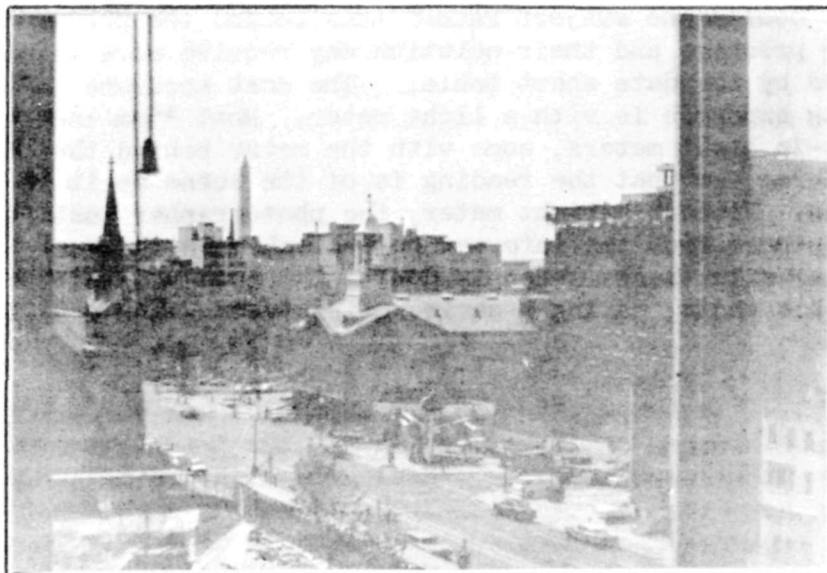

BASIC PHOTOGRAPHY

53.2 Use the data sheet and bracket the exposures. How to put together information about f/numbers, shutter speeds, and film characteristics to get correct exposure? The simplest method is to refer to the data sheet packaged with the film being used. A table on the data sheet gives general guidelines for proper exposure.

**ASA
SPEED**
32

KODAK PANATOMIC-X FILM

**ROLL
&
135**

Use this extremely fine grain film whenever a high degree of enlargement is required.

HANDLING

Load and unload your camera in subdued light. Rewind 135 film into the magazine after you make the last exposure and before opening the camera.

DAYLIGHT PICTURES

Set your exposure meter or automatic camera at ASA 32. If your negatives are consistently too thin, increase the exposure by using a lower film speed number; if too dense, reduce the exposure by using a higher number.

If you don't have an exposure meter or automatic camera, use the exposure indicated in the table below.

OUTDOOR EXPOSURE GUIDE FOR AVERAGE SUBJECTS

Shutter Speed 1/250 Second		Shutter Speed 1/60 Second		
Bright or Hazy Sun				
Light Subjects (Sand or Snow) f/8	Average Subjects f/5.6*	Cloudy Bright (No Shadows) f/5.6	Heavy Overcast f/4	Open Shade† f/4
*f/4 at 1/125 second for backlit closeup subjects.				
†Subject shaded from the sun but lighted by a large area of sky.				



What about situations involving particularly dark-colored or unusually light-colored subjects or backgrounds? What corrections should be made when the sun is behind the subject rather than behind the photographer? These are common problems and their solution may require more information than is provided by the data sheet table. The most accurate method for determining exposure is with a light meter. Most 35mm cameras today have built-in light meters, some with the meter behind the lens (known as BTL cameras) so that the reading is of the scene as it is transmitted by the lens. Without a light meter, the photographer must estimate the correct exposure from the information available in terms of his experience with similar situations. When in doubt, the good photographer will always "bracket" his shots, making a series of pictures using a different setting each time.

53.3 Make a shutter speed/aperture trade-off. You will recall that shutter speed and lens opening work together to let in the proper amount of light to the film, and exposure is always stated in terms of paired values for shutter speed and f/number.

All of these settings let in the same amount of light:

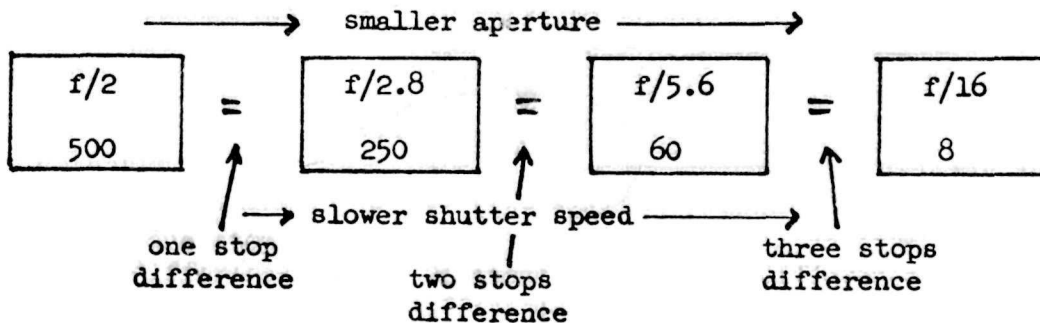

Selection of which pair to use is based primarily on two considerations:

- (1) How much movement or action in the scene? The faster the motion the faster the shutter speed necessary to "stop" the action.
- (2) How much depth of field is required? The greater the depth of field the smaller the aperture necessary to obtain it.

54. USE OF FLASH

Good exposures can usually be made, even under unfavorable lighting conditions, on the high-speed films available today. Even so, it may be necessary at times to provide additional light by means of flash. Flash bulbs or electronic flash are used for this purpose. The exposure for taking pictures with flash lighting is determined by referring to tables in the data sheet that comes with the film, or on the flash bulb box, or in the instructions that come with an electronic flash unit. These directions provide guide numbers for given situations taking into account the strength of the flash, the film speed, and the shutter speed

BASIC PHOTOGRAPHY

to be used. When the guide number and the flash-to-subject distance are known, the lens setting can be determined from the formula:







$$\text{lens setting} = \frac{\text{guide number}}{\text{distance}}$$

FLASH PICTURES

Use Blue Flashbulbs or Flashcubes. Divide the guide number in the table below by the distance from the flash to the subject to determine the *f*-number for average subjects. Use these numbers as *guides*—if your negatives are consistently too thin, increase exposure by using a lower guide number; if too dense, reduce exposure by using a higher guide number.

For successful flash operation, clean battery ends and camera contacts often with an eraser or rough, damp cloth.

In other words, divide the guide number by the distance of the subject from the camera to get the lens setting for the picture.

GUIDE NUMBERS FOR BLUE FLASHBULBS						
Reflector Type	Flashbulb	Shutter Speed				
		F for X Sync	M Synchronization			
		1/30	1/30	1/60	1/125	1/250
	Flashcube	55	40	38	32	26
	AG-1B	40	28	28	24	20
	AG-3B	50	35	35	28	22
	AG-1B	55	40	40	34	28
	M2B	50	—	—	—	—
	AG-3B	70	50	50	40	32
	AG-1B	80	60	60	50	40
	M2B	75	—	—	—	—
	AG-3B	100	70	70	60	45
	M3B, M5B, 5B, 25B	75	75	70	60	45
	M3B, M5B, 5B, 25B	110	110	100	80	60
	6B†, 26B†	—	100	80	55	38

*Polished bowl. †Bulbs for focal-plane shutter.

For example, if you are using flashcubes at 1/125, and your subject is 8 feet away from the camera, divide 32 by 8. This gives you 4, so you use f/4 as the lens setting.

55. COMPOSE THE PICTURE

55.1 The general rules.

The effectiveness of any picture is strengthened by careful arrangement of the elements in it. Composition is largely a matter of personal choice but there are some general rules which should be kept in mind for general photography, and there is one overriding consideration which must

BASIC PHOTOGRAPHY

be remembered with respect to investigative photography. The general considerations are more or less as follows:

- (1) Have only one major subject or center of interest in a scene. Eliminate or subordinate all secondary elements and focus on the main one. Fill the frame with the subject.

Poor

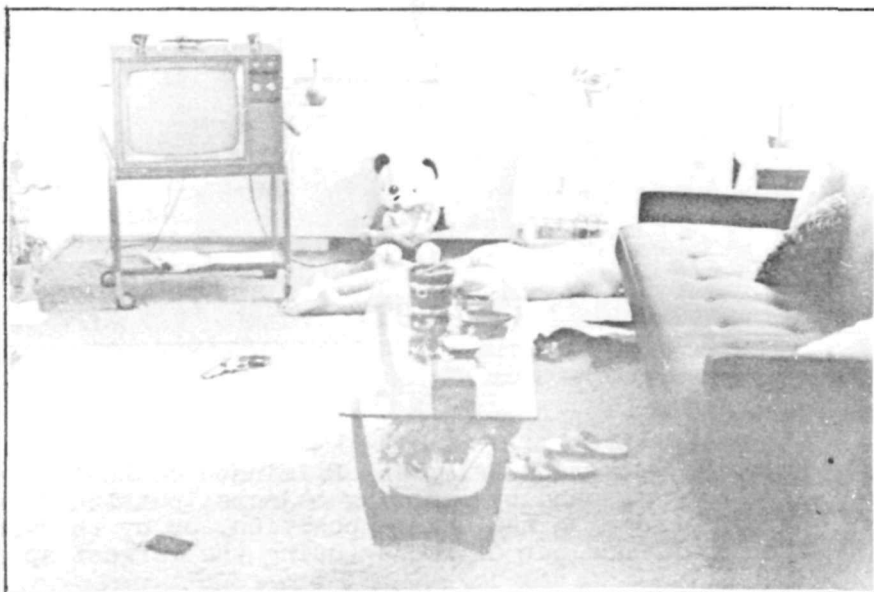

Better

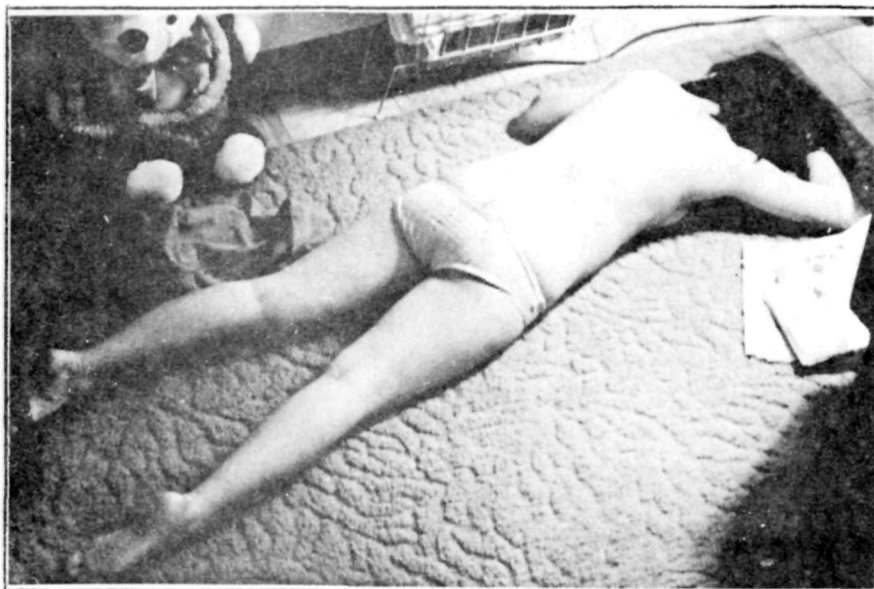

BASIC PHOTOGRAPHY

- (2) Place the center of interest near to but not directly in the center of the picture area. Making the picture slightly unsymmetrical creates a more dynamic arrangement that tends to hold a viewer's interest.



- (3) Keep the background simple. Eliminate confusing details in the background by removing objects, putting up a screen, changing the camera position, or by throwing the background out of focus (using the largest aperture).



BASIC PHOTOGRAPHY

- (4) Include foreground detail to create an impression of depth (principally in long-shot exterior scenes).

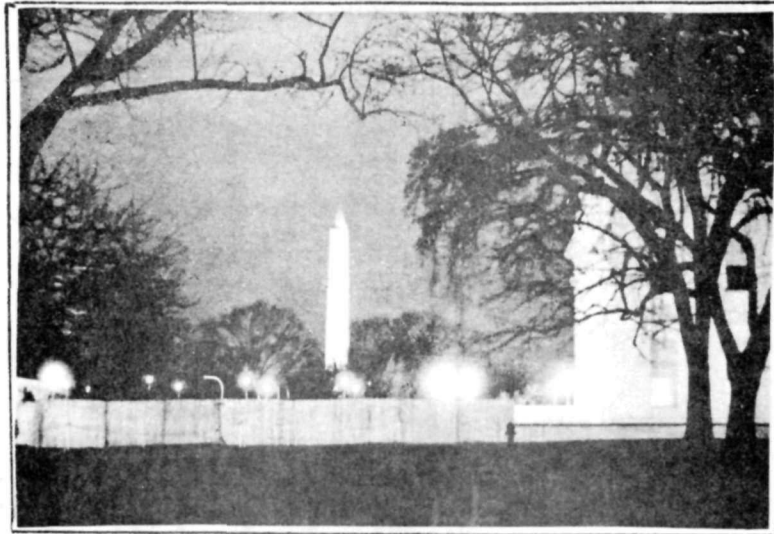

- (5) If action or movement is implied in the picture, allow more space or picture area in the direction of the action rather than away from it.



- (6) If strange or unknown objects are the subject of a picture, include some familiar object for comparison (use a ruler in crime scene photographs).

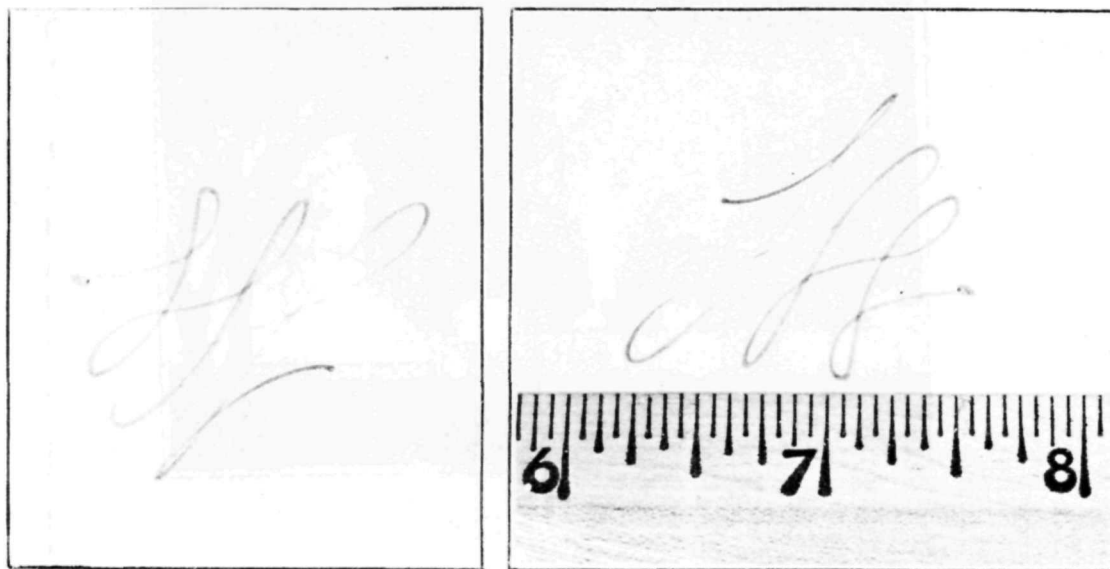

55.2 A fair and accurate representation. The overriding consideration in investigative photography is the need to make a fair and accurate representation of the subject. All other rules must go by the board if they conflict with this requirement. Arty tricks and gimmicks have no place in investigative photography, but the general rules can usually be applied to improve the effectiveness of photographs made for investigative purposes.

56. KEEP A LOG

Professional photographers are acutely aware of the shutter speed/aperture relationship. They often keep elaborate records of these settings and the lighting conditions of the scene they are shooting, even after years of experience. There is no better way to gain a "feel" for different picture taking situations and to build skill in the selection of settings for a particular problem. A good idea therefore, is to keep a log of each picture taken for investigative purposes, recording the aperture and shutter speed settings with a brief description of the scene for identification purposes.

