

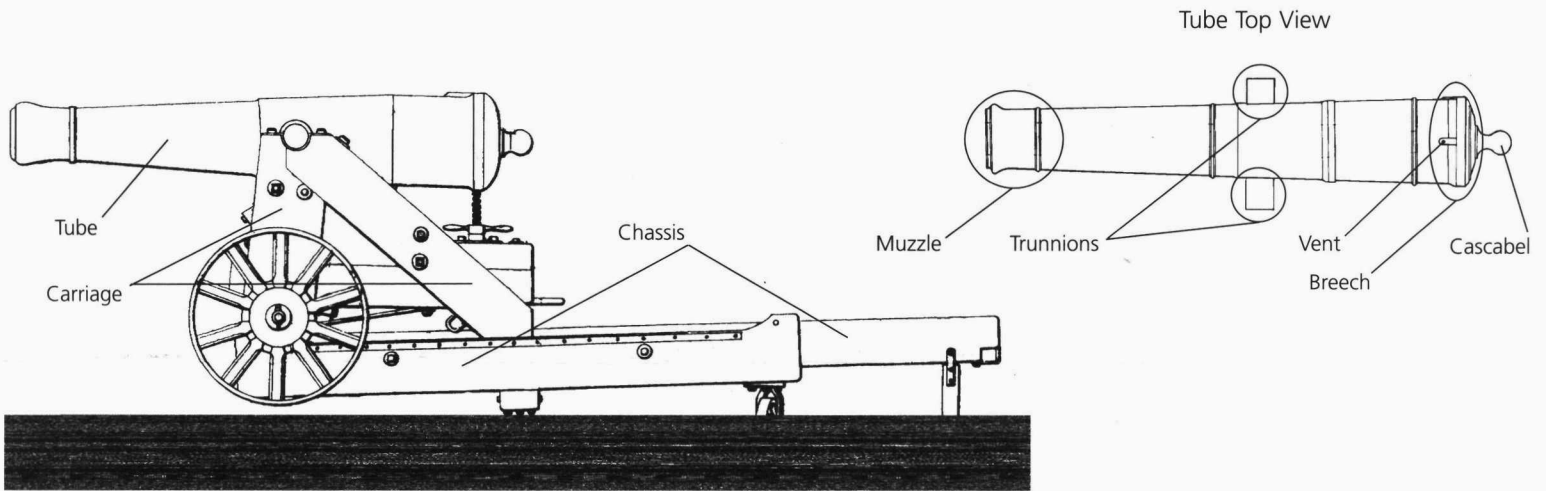

How Does A Cannon Work?



Introduction

This basic guide explains how 19th century seacoast cannon operated, and the types of projectiles they fired. These guns are muzzle loaders; everything entered and left through the muzzle. The gun has three basic components: the tube, the carriage, and the chassis. The tube rests on the carriage, which supports it for firing and controls recoil (energy released when the gun fires). Most tubes are made of cast iron. The tube and carriage rests on a chassis, which permits the movement of the cannon left, right, forward or back to aim, load and fire. All together, this weapon is called a piece.

Smoothbore

Smoothbore guns typically fired spherical projectiles; the classic round cannonball. Ammunition consists of five kinds: solid shot, shell, spherical case shot, canister, and grape shot.



Solid shot are used for puncturing walls, buildings and ships. When heated they become hot shot, used for starting fires.



Shells are hollow with a charge of gunpowder inside. The powder is ignited by a timed fuse, which lights when the gun is fired. Shells are generally used to set fires.

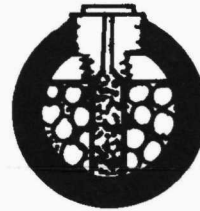

Spherical case shot are similar to shells, but also contain shrapnel (musket balls). These are antipersonnel rounds timed to explode in front of the target while airborne.

Canister and grape shot turns a cannon into a shotgun, killing men and destroying objects alike.

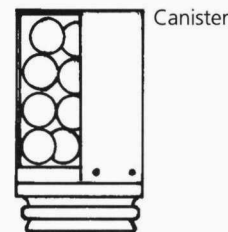

Canister

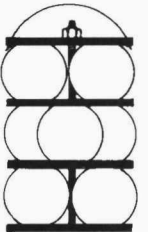

Stand of grape

Rifle

Rifled cannon fire cylindrical, bullet-shaped projectiles. Rifling is a process where the gun's bore is cut with spiraling grooves. The rifling spins the projectile as it is fired, improving accuracy and range. Rifled shells were used, for example, to burrow into a brick wall and then explode, causing much more damage than a simple solid shot.

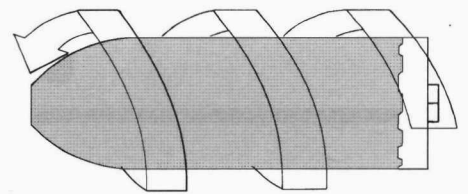

Load...

The process of loading and firing begins with the cannon out of battery, meaning the tube and carriage are as far back on the chassis as possible. Up to eight artillerymen make up a gun crew.

The first order of business is to extinguish any sparks remaining in the bore after the last firing. This is done with a sponge, a long wooden pole

with a head about one inch smaller than the bore. The sponge-head, covered in wool, is dipped in water. The sponge is driven to the breech (the end of the bore opposite the muzzle), turned several times each way and withdrawn.

The next step is to insert a cartridge, a bag of black powder. The bag was commonly made of



Sponge

wool, flannel or cotton. The amount of powder varies with the gun's size, range of target and type of projectile. Then the cartridge is rammed to the breech with a rammer (similar to a sponge without the wool).

Solid shot, shell and spherical case shot are fixed (strapped) to a sabot, a wooden block recessed to

fit the projectile. The sabot keeps the projectile stable while in the tube and protects the fuses of shell and case shot. The fixed projectile is inserted in the bore and rammed home.



Rammer

...Ready...

On the top rear of the gun, a small hole called a vent opens into the breech. A priming wire (much like an ice pick) is driven down the vent (puncturing the cartridge and exposing some powder) and then withdrawn. The carriage is run forward until the tube and carriage rests on the front end of the chassis, in battery.

Traversing, or aiming, the piece is done by moving the chassis left or right. A breech sight is used to give the cannon proper elevation for the range of the target.

A friction primer is the trigger. It consists of a brass tube and a serrated wire key. Surrounding the key is a sparking compound, like the substance

on a match tip. The rest of the tube is filled with gunpowder. The end of the wire key is looped in a circle. A hook tied to a lanyard (a long, sturdy string) is inserted in this loop. Next the friction primer is inserted in the vent. The lanyard is uncoiled and pulled taught.

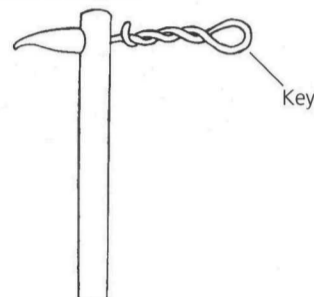

Friction primer. Image courtesy of Warren Ripley.

...Fire!

The final step is performed upon this command. The lanyard is pulled, ripping the wire key out of the primer. This friction ignites the sparking compound and powder inside the friction primer. The

resulting explosion ignites the cartridge, and the cannon fires. Recoil automatically rolls the piece out of battery. Friction brings the carriage and tube to a stop, once again resting on the rear end of the chassis. Then the tube is sponged...

Guns like the Columbiads at Fort Moultrie and Fort Sumter would be fired on average once every eight to ten minutes with a crew of eight artillerymen.

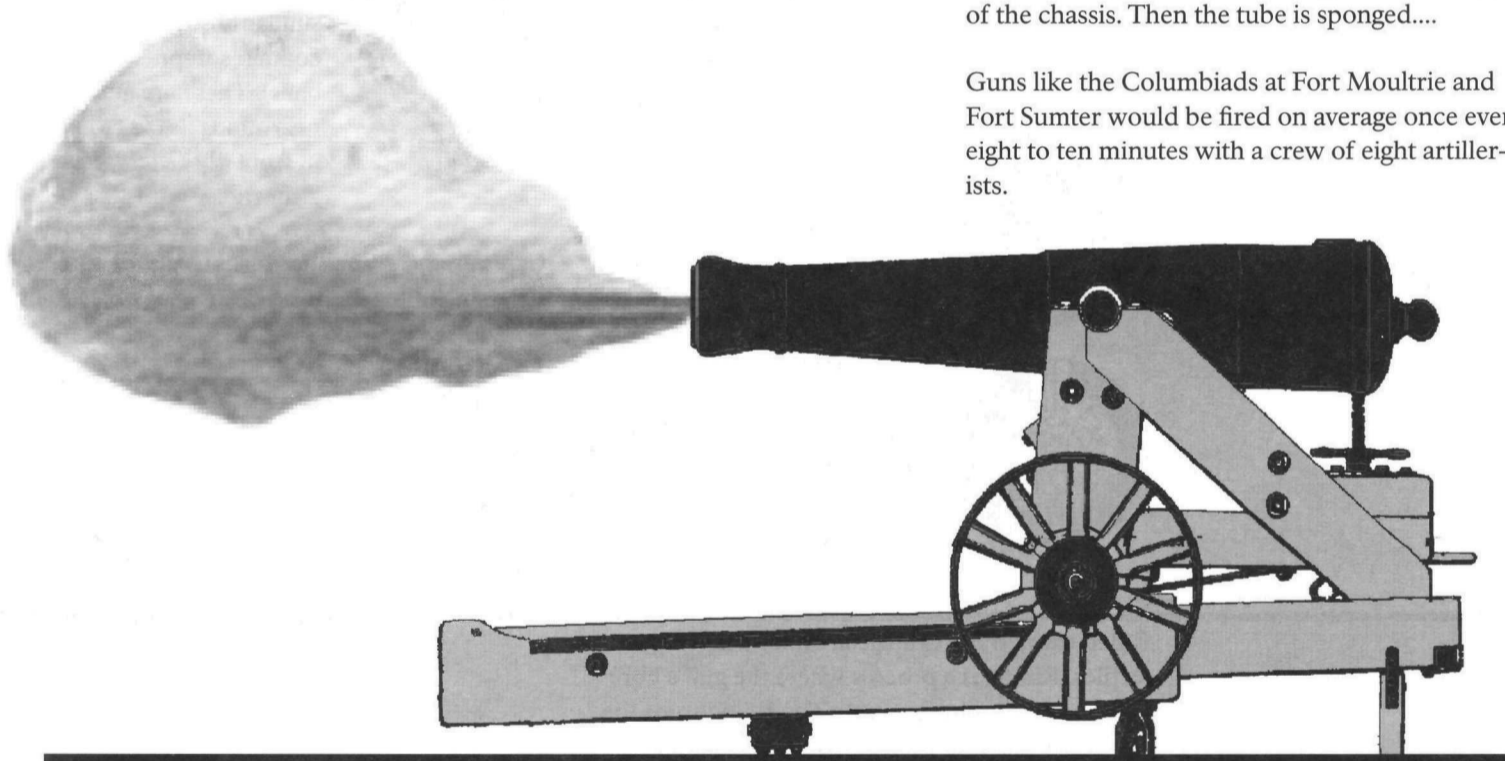

The Modern Era

By the end of the 19th century the United States had upgraded coastal defenses with breech-loading steel guns. These guns were easier to load, had far greater range and accuracy and were more efficient than their predecessors. The age of the old iron muzzle loader was at an end.

Today these guns are artifacts, preserved for all to enjoy. They are displayed whenever possible in their original style settings and mounts. For your safety, no climbing is permitted on the guns, carriages or chassis.

For More Information

Fort Moultrie is a unit of Fort Sumter National Monument, administered by the National Park Service. The site is located at 1214 Middle Street on Sullivan's Island, South Carolina. Hours of operation are daily from 9:00 a.m. to 5:00 p.m., except for New Year's Day, Thanksgiving Day and Christmas Day.

For more information, write to the Superintendent, Fort Sumter National Monument, 1214 Middle Street, Sullivan's Island, SC 29482; call 843-883-3123; or visit is on the World Wide Web at:

www.nps.gov/fosu