



Preservation Tech Notes

WINDOWS

NUMBER 21

Replacement Wood Sash Utilizing True Divided Lights and An Interior Piggyback Energy Panel

Charles E. Fisher
Technical Preservation Services
National Park Service

BEATTY'S MILL (CORAL STREET ARTS HOUSE) Philadelphia, Pennsylvania

Introduction

In the early twentieth century, the desire of property owners to reduce drafts and offset rising fuel costs led to a thriving market for improving the performance of windows. Storm windows and weatherstripping for old and new windows became commonplace. By the 1920s and 1930s, manufacturers began offering sash with dual glazing that also had functional, integral muntins. This feature is still available in traditional styles with true divided lights and a piggyback interior-glazing panel. It has a practical application in the rehabilitation of historic buildings today.

Early Piggyback Storm Panel

Soon after World War I, wood window sash with two layers of glass were being offered by various local and regional companies. Commonly used in wood windows that had integral muntins for the outer glass, the individual glass lights set within these muntins were

glazed in a traditional manner, utilizing glazing putty and metal glazing points. On the room side of the sash, a single-light glass panel, set in a thin metal frame, was mounted flush within the rails and stiles of the wood sash. The metal frame was affixed within the wood sash frame in a manner that permitted it to be occasionally removed when necessary for cleaning the glass. By creating a sash with two sheets of glass, enhanced energy performance was achieved without the need for a separate storm window. It also provided for easier care and use than the traditional combination of an exterior storm window and primary window.

This type of dual glazing was available in a variety of sash styles but appears to be most heavily promoted for double-hung and casement windows. By the 1930s, the dual-glazing feature was part of a standard line of windows made by such nationally known companies

Where the severity of deterioration requires replacement of significant historic windows, the replacement units shall match the old in design, color, texture, and other visual qualities and, where possible, materials.



Figure 1. Constructed in 1886, the Betty's Mill is located at a street intersection. The segmental arched windows are a distinguishing feature of the building.

as the Andersen Corporation and the Rolscreen Corporation (now Pella Corporation).

After World War II, dual-glazed window sash continued to be sold by national, regional and local wood window companies. Although annual sales were never comparable to that of cheaper single-glazed sash, this type of window continues to be marketed today. Technical refinements in gaskets and hardware occurred over time as manufacturers further enhanced the performance of this glazing system.

Even with the growing popularity of sealed insulating glass after World War II and its later dominance in the glazing industry, a market remains today both in new construction as well as rehabilitation work for sash with a piggyback interior energy panel. Several national wood windows companies actively promote such a sash, although without true divided lights. This feature permits companies to offer the convenience of "between the glass" window shades and blinds. The removable panel allows access to the blinds or shades as needed for maintenance.

Some regional and local companies that focus on the historic preservation mar-

ket have taken advantage of a different marketing opportunity. By offering true integral muntins for use with the outer glazing, along with the standard single-light for the interior glazing panel, the appearance of many types of historic windows can be duplicated more accurately than with applied muntins. While providing for improved energy conservation, this system of dual glazing also avoids the eventual failure inherent with sealed insulating glass.

Beatty's Mill (Coral Street Arts House)

Beatty's Mills originally consisted of six interconnected buildings serving as a textile mill complex. The single surviving building is rectangular shaped, five stories in height with details representative of the Italianate style. Constructed in 1886, the brick building is strongly punctuated by repetitive rows of segmental arched windows (see figure 1). This building had changed little over the years and was still being used for textile-related purposes when it was closed around the year 2000.

The New Kensington Community Development Corporation acquired the mill with development plans that

combined low-income housing and artist live/work space. The tall ceiling heights, existing hardwood floors, and large window openings lent themselves well to the new use.

Problem

The large double-hung wood windows were one of the most prominent features of the mill. Each measured 48" by 96" with 12 lights of glass in both the upper and lower sash. Characteristic of many mill windows of the time, the sash frames were set in the masonry walls so as to minimize frame exposure on the outside. This provided for more light on the interior. It also enhanced fire safety through minimizing exposed wood on the outside, thus reducing the risk of flames spreading from an adjacent building fire (see figure 2). The outer face of the meeting rail was quite narrow.

The building had suffered many years of neglect, which was reflected in the condition of the windows. A condition survey determined that 40% of the sash were in poor condition; 45% were in fair condition; and only 15% were in good condition. Based on the window survey, the development team elected to replace the



Figure 2. The historic double-hung wood windows had narrow sash and frame members that contributed to the distinctive qualities of the windows.

Figure 3. Drawings of the historic windows were prepared by the architectural firm based on field measurements to assist in devising an appropriate replacement window. Drawings: Courtesy of Kitchen & Associates Architectural Services.

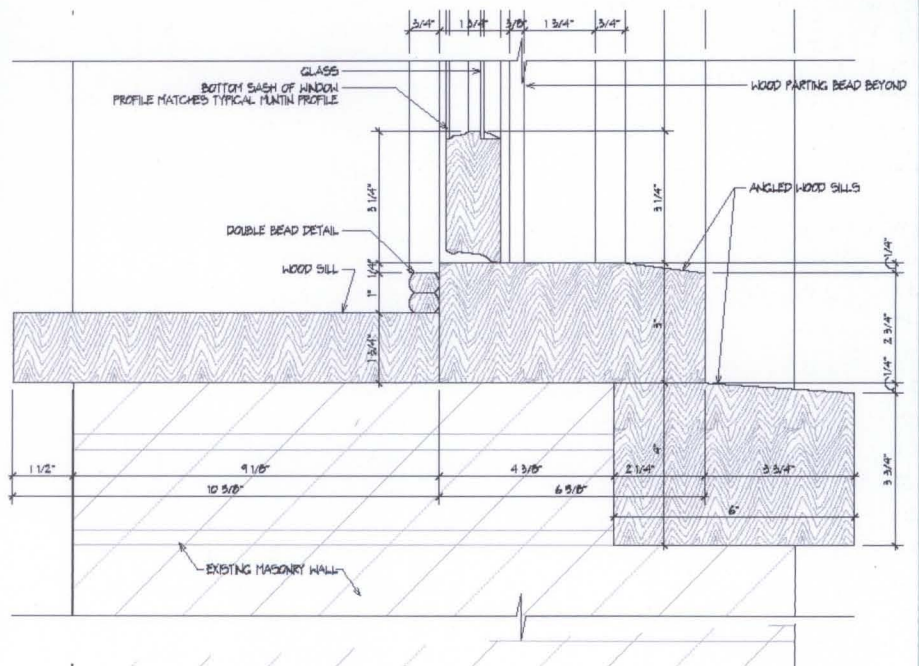
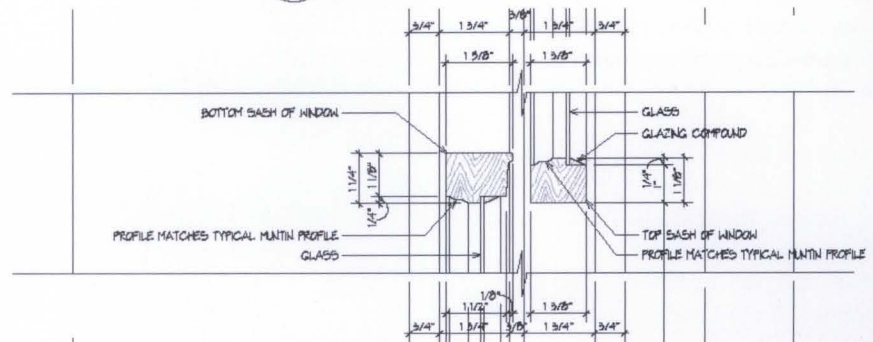
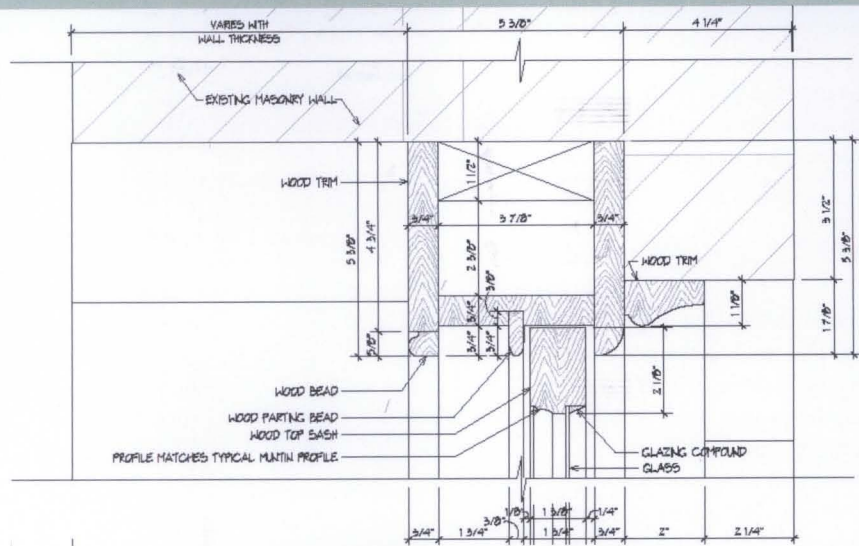
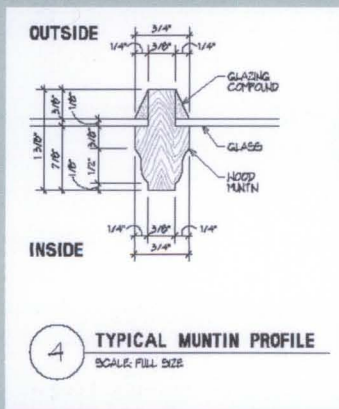
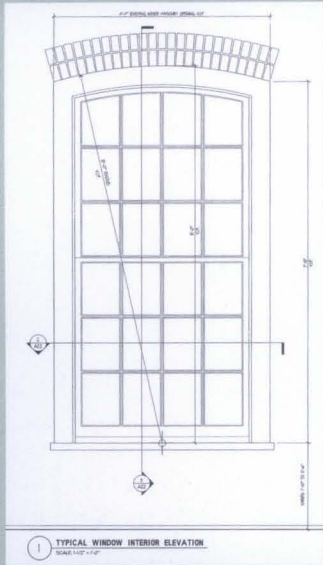

existing sash with new wood sash. The initial plans included retention of the wood frames, utilizing a combination of dutchman repairs, epoxy consolidation, and epoxy repairs. Upon further investigation, it was determined that even the window frames were too deteriorated to repair.

Solution

The location of this building right on a street corner and the importance of the windows to the historic character of the building led the project team to select a window solution that closely matched both the detail and appearance of the historic windows. By selecting a new custom wood window, the narrow site lines of the historic windows could be closely replicated, the historic glass to wood ratio readily maintained, and other historic details easily reproduced (see figure 3).

To help retain the historic sightlines, the deteriorated frames were removed, permitting the new frames to be set close to the masonry (see figure 4). The alternate approach of retaining the existing frames, abutting new frames to them, and covering the outer face of the exposed portion of the older frames would have resulted in reduced glass exposure and a beefier frame appearance to the finished windows.

The small divided-light appearance of the historic windows was initially thought to be difficult to match since energy conservation requirements stipulated dual glazing for the sash. One option, involving a new wood window with true divided lights and a separate interior storm window, was not considered practical in this case. Another option utilizing grids applied onto a sealed insulated glass unit was determined by the project team to be an insufficient match of the historic window.

A third option called for the use of a wood window with true divided lights for the outer glazing and an applied interior single-light glass panel on the inside of each sash. The project's preservation consultant, Robert Powers of Powers & Company, knew this window approach has been used successfully on historic rehabilitation projects for more

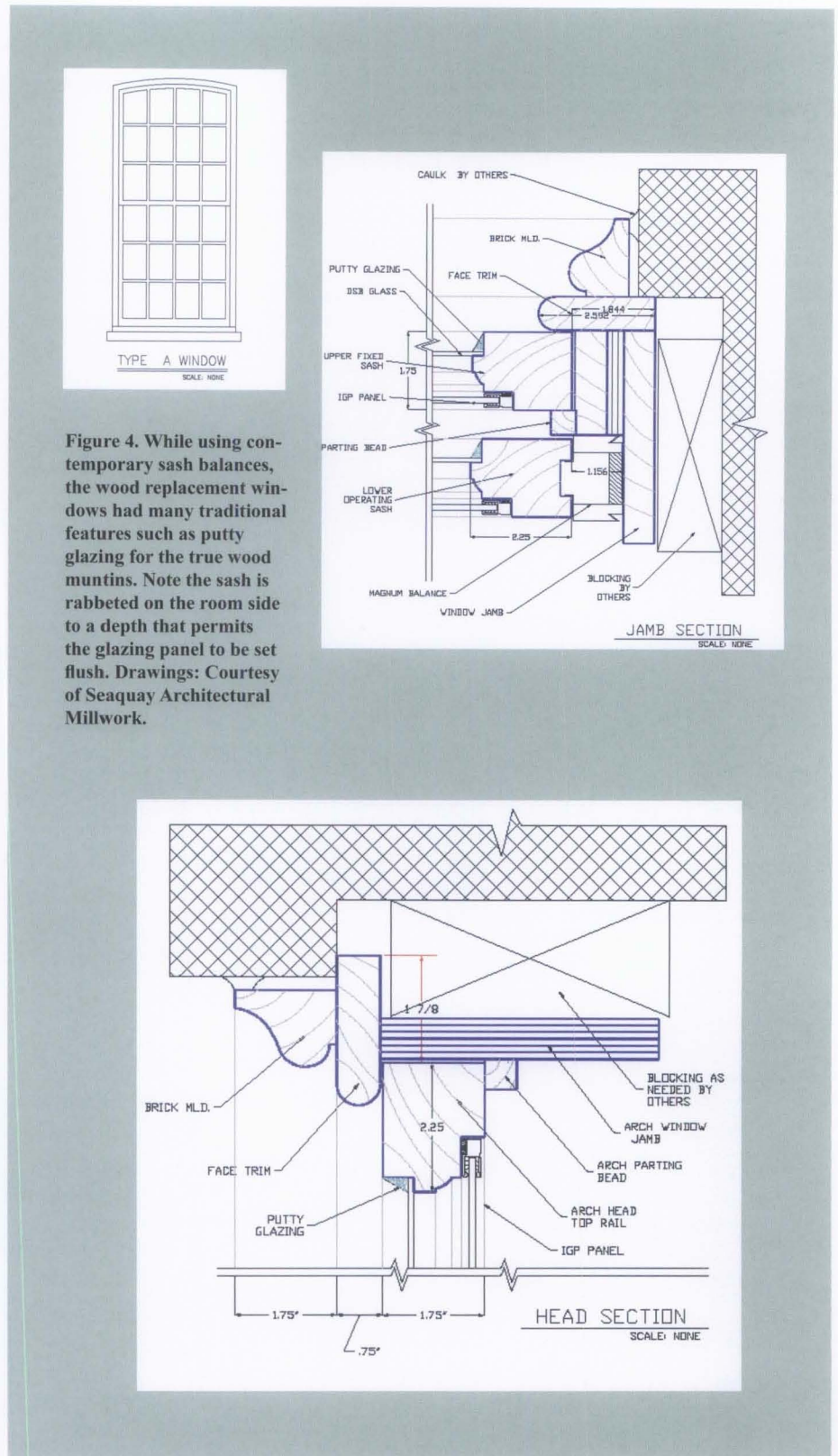

Figure 4. While using contemporary sash balances, the wood replacement windows had many traditional features such as putty glazing for the true wood muntins. Note the sash is rabbeted on the room side to a depth that permits the glazing panel to be set flush. Drawings: Courtesy of Seaquay Architectural Millwork.

than 20 years. This option provided for a close match of the historic window, was affordable, insured ease of operation for residents, and provided dual glazing for energy purposes.

The project team selected the third option, and the architectural firm prepared

drawings both of the existing windows and the proposed replacement windows as part of the bid documents. Seaquay Architectural Millwork Corporation, located near Philadelphia, was selected for the window work. The company had manufactured windows for 18 years and made this style of dual-glazed wood

Figure 5. For the new windows to meet ASTM Standards, the face width of the meeting rail was increased 1/2 inch. To both accommodate the piggyback energy panel and match the historic muntins, the thickness of the wood sash was increased from 1 3/8" to 1 3/4". These two changes had minimal visual impact, considering the size of the windows. Drawings: Courtesy of Seaquay Architectural Millwork.

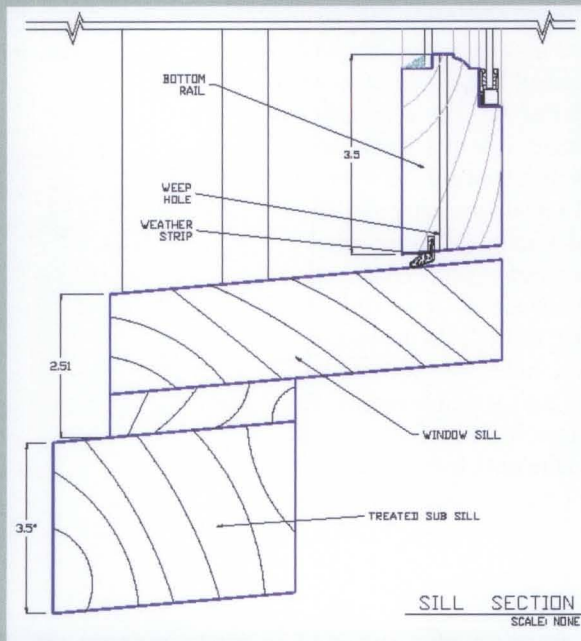
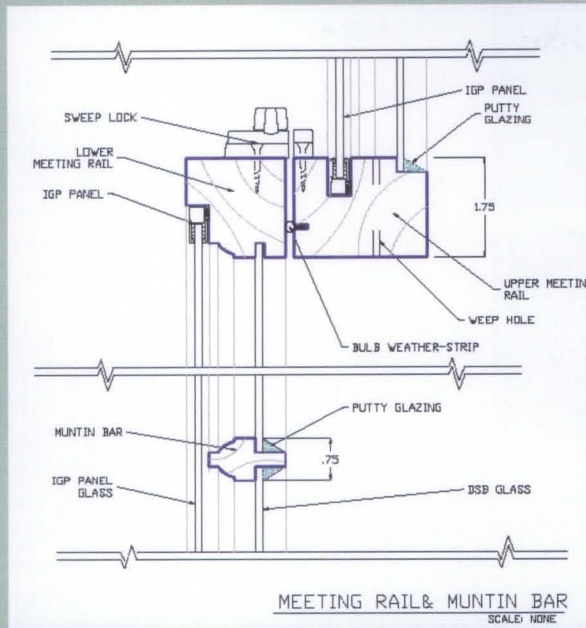

window for both small and large size residential, commercial and institutional buildings.

In matching the exterior appearance of the historic windows, two issues arose that were successfully addressed. First, in order to meet the energy

requirements of the various funding agencies, it was necessary to use Low-E glass. By locating the Low-E glass in the interior energy panel and with the energy panel being placed nearly one inch from the outer glass, the color difference of Low-E glass and its slight light distortion were minimized when

viewed from the outside. With the Low-E glass, a U-factor of .38 was achieved.

Somewhat more problematic was how close the bottom rail (meeting rail) of the new upper sash could match the narrow width of the existing window. Specifications for the project required that the replacement window meet three ASTM Standards: ASTM E283, the standard test for determining the rate of air leakage through an exterior window; ASTM E331, the test of water penetration; and ASTM E330, the standard test for structural performance of an exterior window. To meet ASTM E330 with the design pressure rating for the window set by the architect, a 1 3/4" wide meeting rail was needed (see figure 5). This was an increase of 1/2 inch over the historic sash. Fortunately because of the size of the window, this increase was considered acceptable, as the meeting rail still appeared relatively narrow even with the 1/2 inch increase.

Fabrication and Assembly

All but four of the 192 double-hung windows to be replaced measured 48" wide by 96" high. The upper sash were to have a segmented arch at the top rail and the frame was to have a common brick molding of wood. The 3/4 inch wide muntins in the new sash were to match the historic ones and when glazed create a trapezoidal shape on the outside.

Seaquay prepared three-quarter scale shop drawings for the new windows and submitted them for approval to the architect (see figures 4 and 5). Sufficient time was provided to also allow the project team to obtain approval from the various historic preservation review agencies. To insure that the windows would meet the performance specifications set by the architects, a window was fabricated and tested at the company, then sent to an independent testing laboratory.

Following the results of the testing, full production of the new windows commenced using northeast pine for all wood members. Seaquay already had the knives to match the profile of the 3/4 inch wide muntin and ran lengths of the sash components through an onsite molder. (Because the company is a custom millwork shop and considering the size



Figure 6. The outer glass was installed in the traditional manner, using exterior glazing putty. Photo: Charles Fisher.

of the project, the cost for new knives to match a historic muntin profile would not have been expensive.) After all the cuts were made and joints prepared, the wood parts were dipped in a water-based preservative that included a fungicide, in accordance with the Window and Door Manufacturers Association's industry standard for water repellent preservative treatment of millwork.

The windows were then assembled and sanded. The outer glass was installed in the factory after the assembled sash were primed. Exterior glazing putty manufactured by C.R. Lawrence was applied in the traditional manner (see figure 6). Since the upper sash were to be fixed in the operable windows, weatherstripping and block and tackle balances were provided only for the lower sash. Each window was provided with two sweep locks and two sash lifts for the operable lower sash. Of the 188 replacement windows, 111 were single hung and 77 were fixed (see figure 7).

The aluminum frame glazing panels were manufactured by Seaquay using a C Sash aluminum frame also purchased from C.R. Lawrence. The C Sash product has the weatherstripping for the glass and is surfaced on one side with weatherstripping to effect a reduction of air infiltration.

Seaquay delivered the windows to the job site with the aluminum-frame glass panels separate. The aluminum-frame glass panels were attached to the wood sash with metal screws after the windows were installed and had received

their final coat of paint on the interior muntin bars. This was the contractor's choice. The muntin bars could have been painted in the shop in the finish color and delivered complete to the job site.

Several features of the new window were different than the historic windows in order to accommodate the dual glazing. The inside of the rails and stiles of the sash were rabbeted on the room side to a depth that permits the glazing panel to be set flush. To retain the depth of the original muntin and to accommodate the glazing panel on the inside, the thickness of the sash was increased to 1 3/4". In the bottom rail, weep holes were provided between the glazing panel and the outer glass, to allow water to drain from condensation that might on occasion develop between the two layers of glass.

Project Evaluation

The new windows in Beatty's Mill successfully matched the historic units while providing enhanced energy conservation. There is little difference between the new and historic windows in terms of the characteristic features (see figures 2 and 7). The integral wood muntins, individual panes of glass, reflective qualities of the glass, glazing putty, and painted wood surfaces, along with the benefits of using a custom-wood window manufacturer that could duplicate

the historic features, all contributed to the successful match.

The aluminum frame for the interior glazing panel can be ordered in a factory applied finish to match the inside sash color, left unpainted, or painted the color of the sash at the job site. In the later case, it is important to first remove the glazing panel, paint, and allow for sufficient drying prior to reinstallation.

Cleaning the glass surfaces in between the two glazing layers will be occasionally needed. For ease in removing and reattaching the glass panel, the use of set screws or latch levers to secure the panel to the sash is recommended. Some conditions may lead to more than occasional condensation forming on one of the glass surfaces in between the two layers. For example in northern climates, this condition may occur in a bathroom or kitchen, especially where mechanical or window ventilation is not properly used. Besides weep holes, some manufacturers install



Figure 7. The new window's joinery, individual glass lights, reflective qualities, and painted wood finish all help to capture the appearance of the original units.

An Established Solution for Buildings of All Sizes

The window system described in this Preservation Tech Note has been used in a wide range of historic rehabilitation projects in numerous states. Projects have varied in size from 25 to over 1000 windows. Some other projects by the window company responsible for Beatty's Mill are illustrated here.



A.

Figure A. Building 10 (headquarters of Urban Outfitters), former Philadelphia Naval Shipyard. New wood windows were made to match the original units, including true divided-lights, while incorporating a piggyback interior energy panel. Photos: Seaquay Architectural Millwork.



Figure B. 61-63 North Arch Street, Philadelphia (commercial and residential). Most of the historic windows were missing or severely deteriorated prior to the rehabilitation of this corner building. Based on surviving units, new non-clad wood windows were milled with matching true divided lights and piggyback energy panels. Photo: NPS file.

Figure C. Anthony Wayne School (affordable senior housing), former Philadelphia school. The predominant window type is a wood unit with four-over-four glass lights as shown in the lower right-hand photograph. The replicated wood window on the right is shown with the energy panels installed, while both sash in the left window have yet to receive the panels shown in the left forefront.

B.



C.





Figure 8. Upon completion of the work, the former mill now serves as low-income housing and artist live/work space. The new wood windows provide improved energy performance and enhance the visual qualities of the historic building.

breather holes placed on the sides of the wood sash to help address this issue.

While the origin of the piggyback interior storm panel more than 75 years ago will probably never be known, its use in historic preservation projects is firmly established today (see page 7). This window treatment preserves important features of

the traditional true-divided light sash while incorporating dual glazing for energy conservation. Its use at Beatty's Mill and even larger buildings demonstrates that this type of a dual-glazed wood sash can be a viable window solution for projects of varying size (see figure 8).

This Preservation Tech Note was prepared by the National Park Service. Charles E. Fisher, Technical Preservation Services, National Park Service, serves as the Technical Editor of the series. Information on the window work at Beatty's Mill was generously supplied by Larry Knowles, President, Seaquay Architectural Millwork Corporation, and Robert M. Powers, Powers & Company. Thanks also go to Bonnie Wilkinson Mark of the Pennsylvania Historical and Museum Commission, and Rebecca Shiffer and Kaaren Staveteig of Technical Preservation Services, National Park Service, for their assistance. Unless otherwise credited, photographs are courtesy of Powers & Company.

Preservation Tech Notes are designed to provide practical information on traditional practices and innovative techniques

for successfully maintaining and preserving cultural resources. All techniques described herein conform to established National Park Service policies, procedures and standards. This Tech Note was prepared pursuant to the National Historic Preservation Act Amendments of 1980 that direct the Secretary of the Interior to develop and make available to government agencies and individuals information concerning professional methods and techniques for the preservation of historic properties.

Comments on the usefulness of this information are welcomed and should be addressed to Preservation Tech Notes, Technical Preservation Services, National Park Service, 1840 C Street NW, Washington, DC 20240.

ISSN: 0741-9023

PROJECT DATA

Owner:

Coral Hagert Streets, L.P.
2515 Frankford Avenue
Philadelphia, PA

Project Date:

2004-2005

Architect:

Kitchen & Associates Architectural
Services, PA
1725 Pine Street
Philadelphia, PA 19103

Preservation Consultant:

Powers & Company Inc.
211 North 13th Street, Suite 500
Philadelphia, PA 19107

Window Manufacturer:

Seaquay Architectural Millwork Corporation
P.O. Box 308
Bridgeport, PA 19405

Project Costs:

The overall cost for the rehabilitation of the Beatty's Mill was \$6,842,995. The cost of the windows delivered by the manufacturer was \$236,000 (price included exterior door work).